

République Algérienne Démocratique et Populaire
Ministère de l'Enseignement Supérieure et de la
Recherche Scientifique



Université Echahid Hamma Lakhdar d'El-Oued

FACULTE DE TECHNOLOGIE

DEPARTEMENT DE GENIE MECANIQUE



Mémoire de fin d'étude

Présenté pour l'obtention du diplôme de

MASTER ACADEMIQUE

Domaine : Sciences et Technologies

Filière : Génie mécanique

Spécialité : Énergies renouvelables

Thème

Evaluation Expérimentale des Performances de Séchoir
Solaire Cylindro-Parabolique pour les Produits
Agroalimentaire

Devant le jury composé de : Présenté par :

KHACHANA MOHAMMED Président

BERKANE HOUDA Examinateur

LAOUINI ABDELDJALIL Encadreur

-BENLAMNOUAR LAMNOUAR

- BERGUIA AHMED

- AMEUR FADHILA

2019-2020

Summary

Acknowledgments	I
Dedication.....	I
Summary.....	III
Liste des figures.....	IV
Liste des tableaux.....	V
General introduction	VI
Chapter I solar deposit and terminology of drying	
I.1 Introduction	1
I.2 Solar deposit.....	1
I.2.1 The solar star.....	1
I.2.2 Physical parameters of the solar star.....	1
I.2.3 Solar radiation.....	2
I.2.4 Influence of the atmosphere on solar radiation.....	4
I.2.5 Measurement of solar radiation on earth.....	6
I.3 Basic principles and terminology	7
I.3.1 Drying.....	7
I.3.2 Humidity.....	7
I.3.3 Moisture content	7
I.3.4 Adsorption isotherm.....	7
I.3.5 Psychrometry.....	8
I.3.6 Equilibrium Moisture Content.....	8
I.3.7 Water Activity.....	9
I.3.8 Drying Kinetics.....	9
I.4 Drying mechanism.....	10
I.5 The different drying modes	12
I.6 The three drying phases.....	12
I.7 Conclusion.....	13
Chapter II Solar dryers and solar collectors	
II.1 Introduction	14
II.2 The different types of solar drier.....	14
II.2.1 Passive solar dryer or natural convection.....	15
II.2.2 Active solar dryer or forced convection	15
II.3 Direct solar dryers.....	15
II.3.1 Working principle.....	16
II.3.1 Advantages.....	16
II.3.1 Disadvantages.....	16
II.3.1 Direct solar dryers Type.....	16
II.4 Indirect solar dryers.....	20
II.4.1 Working principle.....	20
II.4.2 Advantages.....	20
II.4.3 Disadvantages.....	20
II.4.4 Indirect dryer type.....	21
II.5 Hybrid dryers.....	21
II.5.1 Advantages.....	22
II.5.2 Disadvantages.....	22
II.5.3 Types of hybrid dryers.....	22
II.6 Mixed dryer	24
II.7 Solar collectors.....	25

II.7.1	Thermal solar collectors.....	25
II.7.2	Photovoltaic solar collectors.....	25
II.8	Conclusion.....	27

Chapter III Material and product preparation

III.1	Introduction	28
III.2	Preparation of the products to be dried.....	28
III.2.1	Banana.....	28
III.2.2	Potato.....	30
III.3	Equipment used	31
III.3.1	Solar dryers assisted by parabolic cylindrical collector.....	31
III.3.2	Collector.....	32
III.3.3	The receiver.....	32
III.4	Measuring instruments.....	33
III.4.1	Temperature measurement.....	33
III.4.2	Weight measurement.....	33
III.4.3	Solar radiation measurement	34
III.5	Conclusion.....	34

Chapter IV Results and discussion

IV.1	Introduction	35
IV.2	Banana drying curves.....	36
IV.3	Conclusion.....	37
	General Conclusion.....	38

General introduction

Solar energy is a clean source of energy and is available almost universally and most often among all renewable energy sources, the source of almost all energy sources used in the world. Which sums up the general concepts of solar energy and the sun.

Drying is an operation consisting in lowering the activity of the liquid of a product, in reaching a threshold beyond which the enzymatic and oxidation reactions are inhibited, as well as the development of microorganisms.

Drying is one of the most important processes in maintaining many food products, and it is often the last process (usually after evaporation) in product manufacturing. It is a thermal separation process, which involves the removal of all or part of a so-called "wet" drink that evaporates this solvent. The end product is called "dry", although it does contain residual moisture.

The use of solar dryers helps to maintain optimum use for agricultural products. Experimental study of solar drying through a parabolic cylindrical concentrator for agricultural products, and then to carry out some tests on agricultural products such as bananas, potatoes.

This dissertation contains four chapters:

- Chapter I: is devoted to bibliographic research and general concepts of solar energy, applications, thermal and solar transfer.
- Chapter II: provides general information on drying and solar dryers and their operation.
- Chapter 3: describes agricultural products and method of preparation such as bananas and potatoes to be dried.
- Chapter IV: includes some of the results of drying agricultural products such as bananas, potatoes. Finally, it summarizes the general conclusion and the content of this study.

I.1 Introduction

Drying is an important step that is taken in the different food industries, where the purpose of this step is to reduce the water content of the treated products, to neutralize bacterial and fungal activities, resulting in long-term food survival, drying is one of the solutions suggested to the question of the availability of many agricultural products consumed in large amounts during the four seasons.

There are three types of dryers used for drying agricultural goods, including industrial dryers that rely on electric power or diesel, the second type of solar dryers that rely on solar energy and the third type is the hybrid dryer both solar and electric power.

Solar drying presents a food product treatment process that is based on solar energy. This energy presents a cleaner and cheaper source, is considerably appreciated as an alternative both in the field of industry and research.

Solar drying is currently the research area, we have set aside this chapter for the theoretical study of this science.

I.2 Solar deposit

I.2.1 The solar star

It is useful to make a brief overview of the solar star which is the origin of all life on earth. The sun machine is considered to be a large nuclear power plant providing energy and keeping its waste (ideal nuclear power plant). This machine delivers us clean (non-polluting) energy, free, available, silent, and it never breaks down. We do not make any effort to produce this energy but we only design devices to capture it.

I.2.2 Physical parameters of the solar star

The sun is a pseudo-sphere of plasma (ionized matter) with a radius equal to 695,980 km, or 109 times the radius of the earth. It is located at an average distance of 149,598,000km from land. The angular diameter of the sun, seen by a terrestrial observer, has an average value of 32 'or approximately 0.50C. The sun is formed from a gaseous mass of 1.9891 1030kg composed of the elements hydrogen, helium and a mixture comprising all the other elements of Mendeliev's table; these components are in respective proportions of 80%, 19% and 1%. Its density is 1.41 that of the earth is equal to 5.5 [1].

The solar star has a non-homogeneous pseudo-spherical shape made up of several concentric layers. We find from the center to the outside according to current theories:

- **The core**

Of unknown size and composition and which is inaccessible to investigations because all the radiation emitted in this region is totally absorbed by the outer layers. The temperature reaches 15 million degrees and the pressure reaches 1 billion atmospheres. It is in the nucleus that a series of complicated exothermic thermonuclear reactions (nuclear fusion) called the Bethe cycle occur, which transform hydrogen into helium and which is written globally:

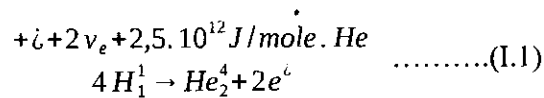

Where e^+ denotes the positive electron, ν_e electron neutrino.

- **A radiative zone**

Radiative combustion zone 500,000 km thick through which energy is conveyed only by radiation.

- **A convective zone**

Convective zone 100,000 km thick through which energy is driven by convective movements.

- **The photosphere**

Only 400km thick, the temperature on its surface is around 4500 ° K, beyond the photosphere the structure of the sun is generally known as the solar atmosphere.

- **The chromospheres**

With a thickness of 8000 km, where the temperature increases from 4500°K to 50,000 ° K towards the outside.

- **The solar corona**

Representing the halo of the sun, extends up to 250 106 km in interplanetary space.

The temperature ranges from 1 to 2 million degrees [2].

1.2.3 Solar radiation

Knowledge of solar radiation in all its aspects is necessary in any application of solar energy. This radiation is disturbed when it crosses the atmosphere (absorption, reflection, refraction), something that must be taken into consideration, as well as the spectral distribution according to the wavelength because the energy receivers are generally selective and operate in an appropriate frequency band. For this we have seen useful to define below some essential concepts for solar radiation.

▪ Solar spectrum

Solar radiation is made up of a flow of particles called photons emitted by the sun and moving at a speed of $3,10^8 \text{ ms}^{-1}$. These photons, which make up electromagnetic radiation, carry an energy according to Louis de Broglie's law

$$E = h\nu = h \frac{c}{\lambda}$$

Where h is Planck's constant, ν is the frequency, c is the speed of light, λ wave length.

The spectrum of solar radiation is its decomposition into wavelengths or "colors". Sunlight is composed of all kinds of radiation of different colors, characterized by their wavelength range which extends outside the atmosphere practically from $0.1\mu\text{m}$ to $0.4\mu\text{m}$, distributed as follows:

- ✓ Spectral range from $0.1 \mu\text{m}$ to $0.38 \mu\text{m}$ ultraviolet radiation.
- ✓ Spectral range from $0.38 \mu\text{m}$ a $0.78 \mu\text{m}$ visible radiation.
- ✓ Spectral range from $0.78 \mu\text{m}$ a $0.4 \mu\text{m}$ infrared radiation.

▪ Solar constant

The solar constant represents the flux of solar radiation received by a unit surface arranged perpendicular to the solar rays.

Suppose that all the energy emitted by the sun is received by the earth (absence of the atmosphere) we will then have:

$$\text{solar constant} = S_0 = \sigma T_s^4 \left(\frac{R_s}{D_{ST}} \right)^2 \dots\dots\dots(1.2)$$

R_s =Sun Ray, D_{ST} =earth-sun distance, $\sigma = 5.67 \cdot 10^{-8} \text{ W/m}^2\text{K}^4$

This flux measured outside the Earth's atmosphere has the average value $(S_{0,ext} = 1353 \text{ Wm}^{-2}$. This value is an average value since the distance from the earth to the sun ($14.945.000\text{km} \pm 1.7\%$) varies throughout the year. It is therefore necessary to apply to the solar constant a correction according to the date n of the day of the year (counted from January 1). The solar constant outside the atmosphere for any day is written according to [2]:
 $(S_{0,ext}) = 1353 (1+0,033\cos0.984n)$ Where n represents the annual calendar (de 1 à 365).

▪ The Albedo

The albedo of a surface is the ratio of the re-emitted power to the power received from solar radiation. A white surface is characterized by an albedo close to 1 while a black surface its albedo is very weak and approaches zero. Soil albedo is often involved; it varies with its nature, its vegetation cover and its state of humidity. For the same soil the albedo varies according to whether it is bare or covered with dry greenery or saturated with humidity.

I.2.4 Influence of the atmosphere on solar radiation

▪ Role of the atmosphere

The earth's atmosphere protects the earth from excess solar radiation and stops the most dangerous rays for the development of life on earth, for example the filtering of ultra violet rays by the famous ozone layer of the stratosphere. This solar energy which descends in a straight line towards our planet cannot reach us on earth in its entirety because it will undergo transformations while crossing the atmosphere: by absorption, reflection, refraction and by diffusion. The structure of this atmosphere conditions, consequently, the various energy transfers ground-atmosphere.

▪ Structure of the atmosphere

The stratification of the atmosphere into three major layers is represented by:

- ✓ The homosphere, between 0 and 90 km altitude
- ✓ The heterosphere, between 90 et 700 km altitude
- ✓ The exosphere, between 700 et 3000 km altitude

The homosphere is subdivided into three main layers listed below:

The troposphere extends from the earth's surface at an altitude of 10 to 16 km. where the temperature and pressure decrease there, respectively by $5.6 \text{ }^\circ \text{C}$ per kilometer and from

400 to 100 mbar to the base of the layer immediately above which is the stratosphere. More than half of the gaseous mass of the atmosphere is in the troposphere; it contains a majority of nitrogen and oxygen (78 and 21% respectively), CO_2 , water vapor, aerosols, clouds of water droplets or ice crystals.

The stratosphere located between 16km and 55km above sea level, it contains several layers, one of which is particularly rich in ozone, has a temperature close to 0°C at the upper limit of the layer. This warming is due to the partial absorption of the ultraviolet radiation emitted by the sun. The pressure is only 1mb at its upper limit, the stratopause.

Ionosphere stretches from 55km to 500km. The ionospheric layers, responsible for radioelectric propagation, are located in overlap between the homosphere and the heterosphere, it is the place of formation of the polar or boreal aurorae characterized by jets of light forming arcs and veils of golden yellow color. . It will be noted that the limits of the layers depend on the latitudes and the seasons.

▪ Air mass

To translate the influence of the atmosphere (Figure 1.1) we introduce the notion of air mass.

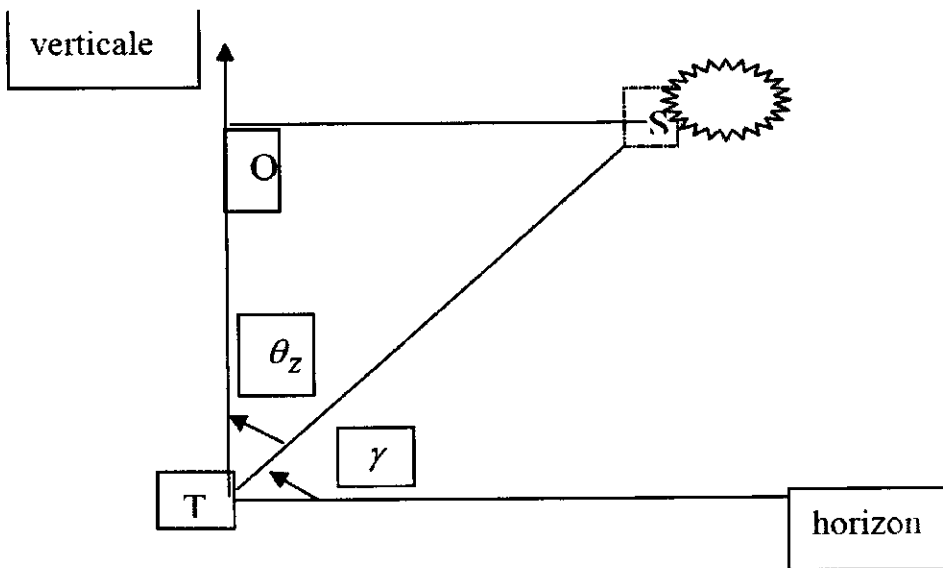

Fig I.1. Atmospheric mass or air mass

$$\text{Air Mass} = \frac{TS}{\zeta} = \frac{\text{path of the solar ray}}{\text{thickness of the atmosphere}}$$

We call air mass, the mass of atmosphere crossed by the direct radiation to reach the ground, compared to a vertical crossing.

The length of the sun's path through the atmosphere is:

$$TS \frac{l}{\sin \gamma} \quad \text{from where} \quad m = \frac{1}{\sin \gamma} = \frac{1}{\cos \theta_z}$$

γ = sun height.

θ_z = zenith angle.

The calculated value of m depends on the altitude of the place (Zen km) and the atmospheric pressure (P in mbar or kPa) [1].

$$m = \left(\frac{1}{\sin \gamma} \right) \left(\frac{P}{1000} \right) \left(1 - \frac{Z}{5} \right) \dots\dots\dots(I.3)$$

By convention, AM_0 designates solar radiation outside the atmosphere.

By convention, AM_1 designates solar radiation vertical incidence.

By convention, $AM_{1.5}$ designates solar radiation tilt at an angle.

1.2.5 Measurement of solar radiation on earth

▪ Components of solar radiation

The solar radiation arriving at the level of our sensor is the sum of two radiations: direct radiation (I) coming directly from the sun, without diffusion by the atmosphere and diffuse radiation (D) which is constituted by the light diffused by the atmosphere and coming from the various obstacles (clouds, aerosols, vegetation, earth... ..etc.) and not having a privileged direction. The sum of the direct radiation (I) and the diffuse radiation (D) constitutes the global radiation (G).

$$G = I + D \dots\dots\dots(I.4)$$

The global radiation is measured experimentally using a pyranometer device whose glass globe gives it a large angular acceptance so that it can capture the rays coming from all directions, when the device is equipped with a sun visor device, it can measure diffuse radiation. Direct radiation (I) is measured using a pyrheliometer, a very expensive device

usually equipped with a controlled system that "follows the sun" in its path. Knowing these two quantities, we can deduce the diffuse radiation using equation (1.4).

▪ Power density

Illuminances are expressed in Wm^{-2} . The solar constant which represents the average illumination of solar radiation outside the atmosphere is close to 1370Wm^{-2} . The average global illuminance at the level of our inclined air sensor at the latitude of Ouargla is around 950Wm^{-2} .

▪ Irradiation or energy density

Represents the energy corresponding to the illumination over a determined period, it is expressed in Wh m^{-2} or in J m^{-2} .

I.3 Basic principles and terminology

I.3.1 Drying

It is the unitary operation aiming at eliminating by evaporation a liquid impregnating a solid or a liquid. The term dehydration has a more restrictive meaning: it only relates to the elimination of water in a solid or in a liquid.

Therefore, drying enables a reduction or even elimination of crop losses through degradation, thereby achieving autonomy over time for food products. The aims of drying are to:

- ✓ Make reservations to market the product during shortages and spread consumption of the product.
- ✓ Transform unsold products.
- ✓ Transport and market more easily.

However, this operation is always accompanied by changes in taste, appearance and loss of nutritional quality of the product or hygiene.

I.3.2 Humidity

This term refers to the liquid in the solid, liquid or pasty body that has to be removed during the drying process.

I.3.3 Moisture content

Water content or moisture content is the quantity of water contained in a material, such as soil (called soil moisture), rock, ceramics, crops, or wood. Water content is used in a wide

range of scientific and technical areas, and is expressed as a ratio, which can range from 0 (completely dry) to the value of the materials' porosity at saturation. It can be given on a volumetric or mass (gravimetric) basis.

I.3.4 Adsorption isotherm

It is the curve representing the variation of the humidity rate at equilibrium as a function of relative humidity equal to the ratio between the partial pressure of the solvent and its saturated vapor pressure at the temperature considered.

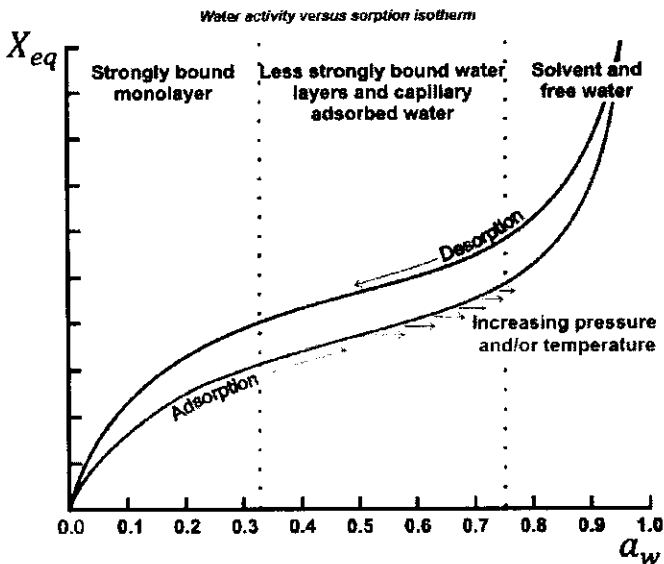

I.3.5 Psychrometry

is the science of studying thermodynamic properties of moist air and the use of these to analyze humid air conditions and processes. Air conditioning processes can be determined with psychrometric charts and Mollier diagrams. Common properties in the charts includes dry-bulb temperature.

I.3.6 Equilibrium Moisture Content

The moisture content of a wet solid in equilibrium with air of given humidity and temperature is termed the equilibrium moisture content (EMC). A plot of EMC at a given temperature versus the relative humidity is termed sorption isotherm. An isotherm obtained by exposing the solid to air of increasing humidity gives the adsorption isotherm. That obtained by exposing the solid to air of decreasing humidity is known as the desorption isotherm. Clearly, the latter is of interest in drying as the

moisture content of the solids progressively decreases. Most drying materials display hysteresis in that the two isotherms are not identical.

Figure 3 shows the general shape of the typical sorption isotherms. They are characterized by three distinct zones, A, B and C, which are indicative of different water binding mechanisms at individual sites on the solid matrix. In region A, water is tightly bound to the sites and is unavailable for reaction. In this region, there is essentially monolayer adsorption of water vapor and no distinction exists between the adsorption and desorption isotherms. In region B, the water is more loosely bound. The vapor pressure depression below the equilibrium vapor pressure of water at the same temperature is due to its confinement in smaller capillaries. Water in region C is even more loosely held in larger capillaries. It is available for reactions and as a solvent.

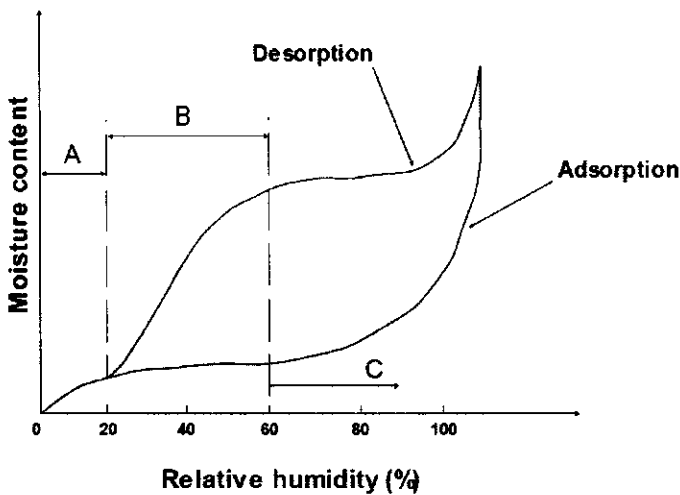

Fig I.3. Typical sorption isotherms

I.3.7 Water Activity

In drying of some materials, which requires careful hygienic attention, e.g., food, the availability of water for growth of microorganisms, germination of spores, and participation in several types of chemical reaction becomes an important issue. This availability, which depends on relative pressure, or water activity, a_w , is defined as the ratio of the partial pressure, p , of water over the wet solid system to the equilibrium vapor pressure, p_w , of water at the same temperature. Thus, a_w , which is also equal to the relative humidity of the surrounding humid air, is defined as:

$$a_w \frac{p}{p_w}$$

I.3.8 Drying Kinetics

The kinetics of drying is the study of the overall behavior of the product to be dried over time. If we consider a wet product placed in a stream of hot and dry air, the evolution of the product during drying is represented by the following curves:

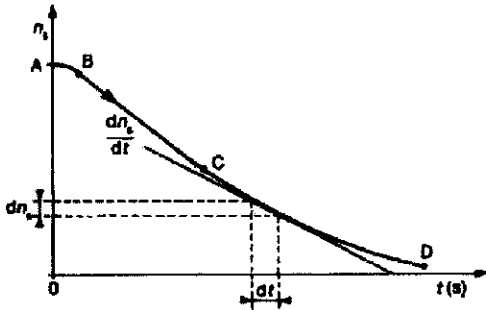

n_s (en kilogramme d'eau par kilogramme de matière anhydre) est le taux d'humidité du produit à sécher.

Fig I.4.a. Drying curve

$$n_s = X = f(t)$$

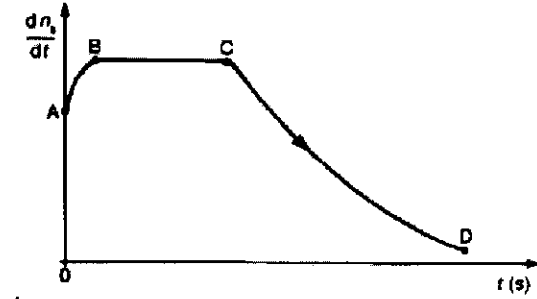

$\frac{dn_s}{dt}$ (en kilogramme d'eau par kilogramme de matière anhydre par seconde) est la vitesse de séchage

Fig I.4.b. Drying curve

$$(dn_s/dt) = (dX/dt) = f(t)$$

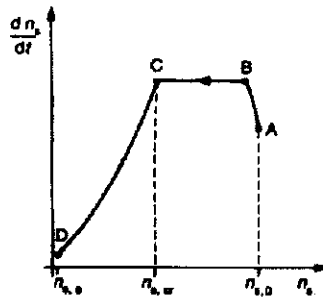

$n_{s,e}$ taux d'humidité à l'équilibre en fin de séchage
 $n_{s,c}$ taux d'humidité critique
 $n_{s,0}$ taux d'humidité initial du produit

Fig I.4.c. Drying curve $(dn_s/dt) = (dX/dt) = f(n_s)$

I.4 Drying mechanism

To dry a product, simply ventilate it with sufficiently hot and dry air. There is heat and humidity exchange between the air and the wet product.

The hot air transmits part of its heat to the product which develops a partial water pressure on its surface which is greater than the partial water pressure in the drying air. The change in pressure allows the substance to be moved from the product surface to the drying air. Thus, the drying process has two significant factors to control:

1. Heat transfer to supply the latent heat needed for vaporization

2. The water or water vapor movement through the wet substance to remove it from the material.

Fig following schematically representation of the wet product, the solid has a film of water which adheres by surface forces to its outer surface.

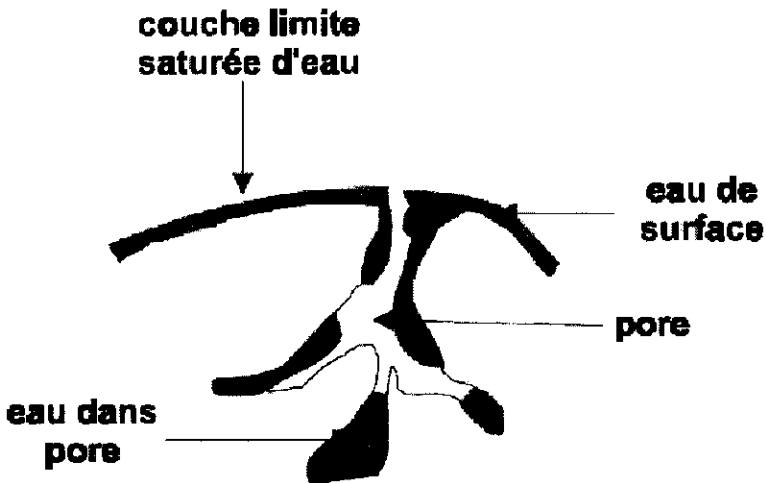

Fig I.1. Schematic presentation of a wet product.

On contact with hot air, the water from the external surface of the product will be evacuated under the effect of the humidity gradient between the air and the product. The osmotic water will migrate in the liquid state from the inside of the grain to this dried periphery by difference in osmotic pressure. During this migration, air pockets appear to replace the water losses. During drying, cell-to-cell diffusion will be more and more hampered by cells which will tend to retain their water. The last points of humidity will therefore be more difficult to remove than the first.

Except for the highly retained water, the liquid water will be fully evaporated. The substance returns to hygrometric equilibrium with its environment; which corresponds to the end of drying.

Drying well means being able to master three fundamental parameters:

- The supplied thermal energy which heats the product and causes water to migrate to the surface and turn it into water vapor;
- The ability of the ambient air to contain the water vapor emitted by the product (also called the entraining air). This efficiency depends on the percentage of

water vapor that is already in the air before entering the dryer and the temperature to which it was brought;

- The velocity of this air at the level of the product, which must be high (up to a certain limit), particularly at the start of drying, in order to facilitate the evacuation of water vapor.

The product should be dried quickly enough to avoid rotting but not too quickly until a crust forms on the surface. When drying at high temperatures, the product becomes darker.

I.5 The different drying modes

There are several modes of drying:

- **Conduction drying:** The product is in contact with hot surfaces;
- **Convective drying:** is the most common way of thermal drying. Gases from combustion or air heaters circulate through or over the product and evaporate the solvent. Convective drying requires large flows of hot drying gas, which is the energy carrier. Its treatment requires special attention;
- **Radiation drying:** is drying by means of electromagnetic waves. A distinction can be made between dielectric drying and infrared drying.

I.7 The three drying phases

Warm-up period [AB]

It is a transient heating phase during which the temperature of the product increases. Physically, it corresponds to a heating phase of the wet product without appreciable reduction in humidity; this probably explains the little interest shown by researchers in the study of this phase, which is generally short-lived.

Constant rate period [BC]

It corresponds to the evaporation of free water at the surface of the product, constantly renewed by water coming from inside the product (partly similar to the phenomenon of perspiration). The temperature of the product remains constant.

Falling rate period [CD]

The falling rate period can be divided into two steps. A first falling drying rate occurs when wet spots in the surface continually diminish until the surface is dried

Second falling rate period begins at point D when the surface is completely dry. The plane of evaporation recedes from the surface. Heat required for moisture removal

is transferred through the solid to the vaporization of moisture in the solid and the vapor moves through the solid into air stream.

However this period may take much longer than constant rate period because the drying is slow.

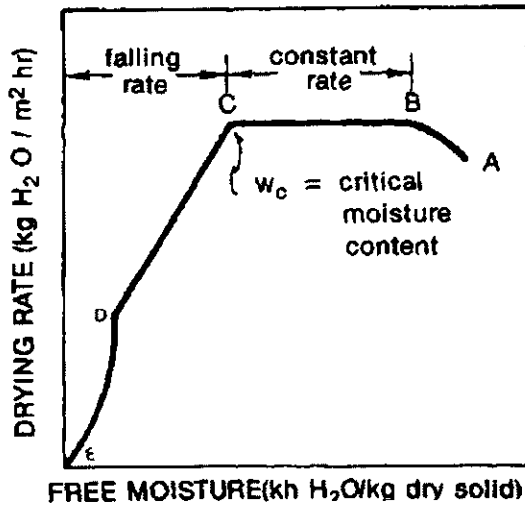

Fig I.2. Drying curve

I.7 Conclusion

The aim of this chapter was to present the essential concepts on the solar deposit, namely the terrestrial coordinates, the sun's movement, various solar radiation components, and others. and Basic principles and terminology of drying , And the various stages of drying for wet product.

II.1 Introduction

There is a wide variety of dryers and depending on the point of view adopted, different ways of classifying them, we can for example, retain as a criterion the texture of the product. Solar dryers are generally classified according to the heating mode or the mode of their operation., Although the collector is considered to be the main component in the dryer Where to capture the solar radiation energy in order to convert into thermal energy, we can then use this heat like all the other heat sources.

In this chapter we will talk about types: solar dryers, collectors and some previous works related to drying and dryers.

II.2 The different types of solar drier

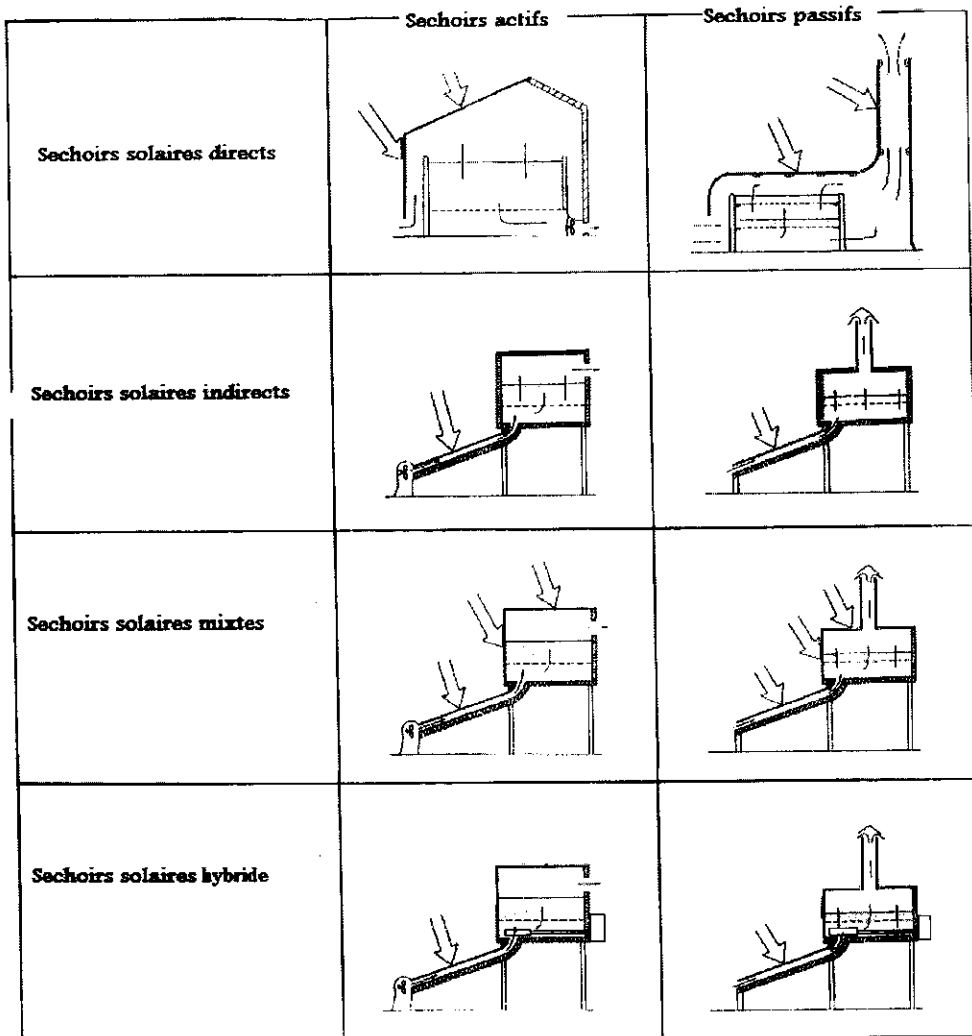

Rayonnement solaire
 Ecoulement de l'air caloporteur

There is a very wide variety of types of dryers, as great as the diversity of products to be dried. The flow rates of product to be dried and their residence time in the dryer differ from one product to another, likewise the drying operation can take a few minutes up to several tens of days.

Generally for agro-food products, solar drying systems are classified according to the heating method (direct by convection, indirect by conduction, by infrared radiation), the heat input mode (direct or indirect) and the handling mode product (accessibility).

There are two main classes of solar dryer for agricultural products:

II.2.1 Passive solar dryer or natural convection

Drying by natural convection uses solar energy, which heats the coolant air and gives it additional water vapor retention power. This warm air continues to rise upward and emanate through a chimney, bringing with it the moisture extracted from the drying product. The flow of the drying air here is by chimney effect. Solar energy alone ensures its operation, these dryers are particularly suitable for regions far from any kind of energy distribution. One of the drawbacks of this type of dryer is the risk of exceeding the maximum temperature allowed by the product, often due to the poor air circulation, frequent in these systems.

II.2.2 Active solar dryer or forced convection

The drying air is forced by a fan, which allows an increase in the evaporating capacity of the dryer. Generally, forced convection largely outweighs natural convection which does not yet make it possible, given the state of research in this matter, to control the progress of drying.

This class of solar dryer allows a better control of the drying operation and a good improvement of the drying time compared to the passive dryer, because the drying air is evacuated quickly and in a continuous way. However, this type of dryer has the drawback: a relatively high production and investment cost compared to the passive dryer, need for local supply of conventional or photovoltaic electricity to operate the fan.

II.3 Direct solar dryers [3] ,[4]

Direct solar dryers are simple to use and to construct. They offer a wide range of design options: from the small-scale box dryer, to the cabin dryer that can handle large quantities.

II.2.1 Working principle

The rays from the sun hit directly on the products. The direct solar dryer consists of one piece that acts as both a drying chamber and a solar collector, the bottom of the drying chamber is painted black to increase the capacity for heat absorption, a sheet of plastic or transparent polyethylene is generally used as a roof but can also use other more expensive materials such as glass or special plastics.

II.2.2 Advantages

- Compared with conventional drying, better protection against dust, insects , animals and rain.
- No skilled labor requirement.
- Great design possibilities.

II.3.3 Disadvantages

- Quality degradation by direct sun exposure, vitamin A and C destruction, wilting, discoloration.
- Fragility of materials made of polyethylene that must be changed regularly.
- Relatively high dryer temperature which contributes to the destruction of nutrients with sun exposure.
- Low circulation of air which limits drying velocity and increases mold risk.

II.2.4 Direct solar dryers Type [11]

II.2.4.1 Drying box

The solar dryer box is an easy-to-build simple dryer by craftsmen, using locally available materials and is generally intended to preserve fruits , vegetables, fish and meat.

In the solar dryer box, the air flows through the orifices drilled from the bottom of the casing (Figure II.1) and flows through the holes at the top of each side. The box and walls at the bottom are painted black to help absorb solar radiation. A plastic sheet or a glass sheet acts as the roof, and a rear panel door enables temperature control.

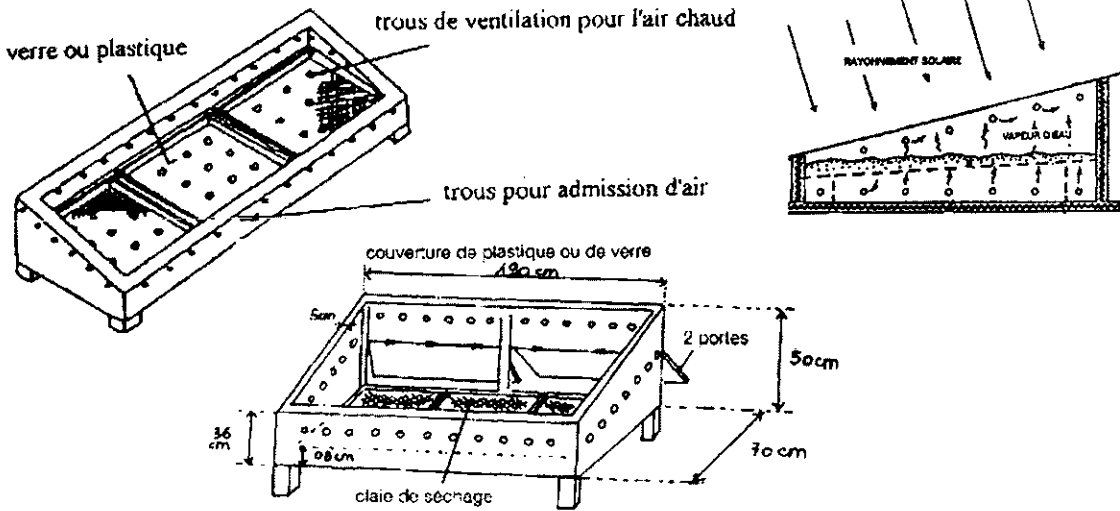

Fig II.1 The solar dryer box

II.2.4.2 The integral dryer with natural convection [9]

The integral dryer (figure II.2) is a direct dryer in which the product is placed in a drying chamber with transparent walls, the solar radiation impinges directly on the product. Direct exposure to sunlight increases the appropriate color ripening of greenish fruits, and allowing the decomposition of chlorophyll in the tissue. For some varieties of grapes and dates, exposure to radiation is considered essential for color development. required in the dry product.

The dryer is equipped with a solar chimney that can be used to increase the buoyancy force imposed on the air stream, thus providing a large air flow and a higher drying rate.

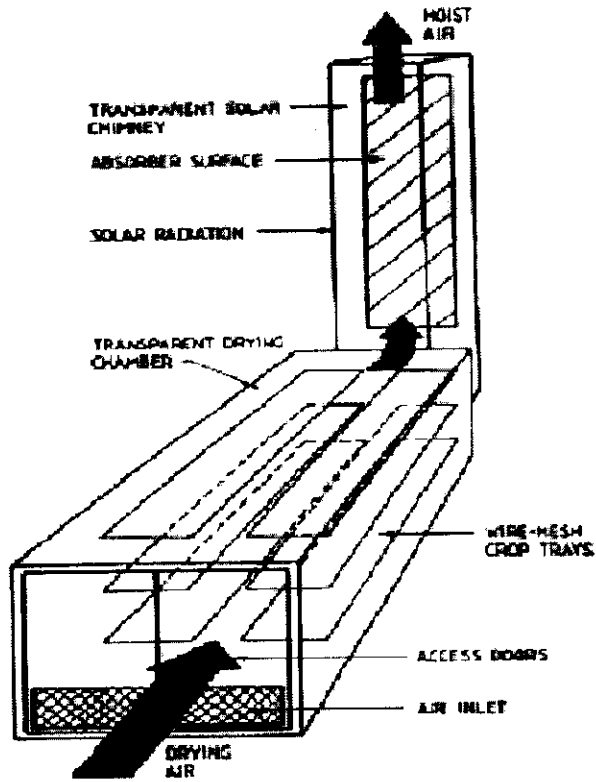

Fig II.2 The integral dryer with natural convection

II.2.4.4 The solar dryer (shell)

The shell dryer is a direct solar dryer with natural convection, designed for local sale and self-consumption. It is used mostly by families, cooperatives and women's organizations. This type of dryer consists of two metal cones connected by a hinge, the black painted sheet ensures good solar radiation collection, perforated holes in the lower and upper sheets that allow air circulation. The dryer's effectiveness is dependent on climatic conditions.

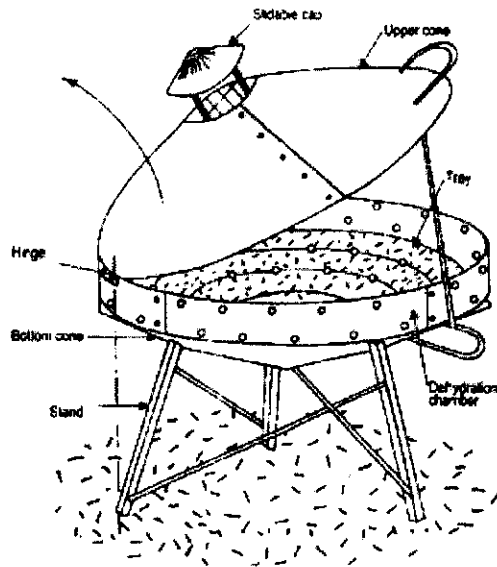

Fig II.3 The solar dryer (shell)

II.2.4.4 The hut solar dryer

The cabin dryer is characterized by a capacity of 35 kg of fresh product for a surface of 7 m². The products are placed in the dryer on racks raised from the ground. The plastic canvas captures the solar energy, a door allows entry into the tent and garnish the hurdles, an air outlet is fitted in the upper part. This type of dryer is characterized by better protection against insects, removable equipment in the rainy season and simple construction and operation, among the disadvantages of this dryer: the cost is quite high, the need for a large polyethylene surface and the wind resistance which makes these models fragile if the location is poorly chosen.

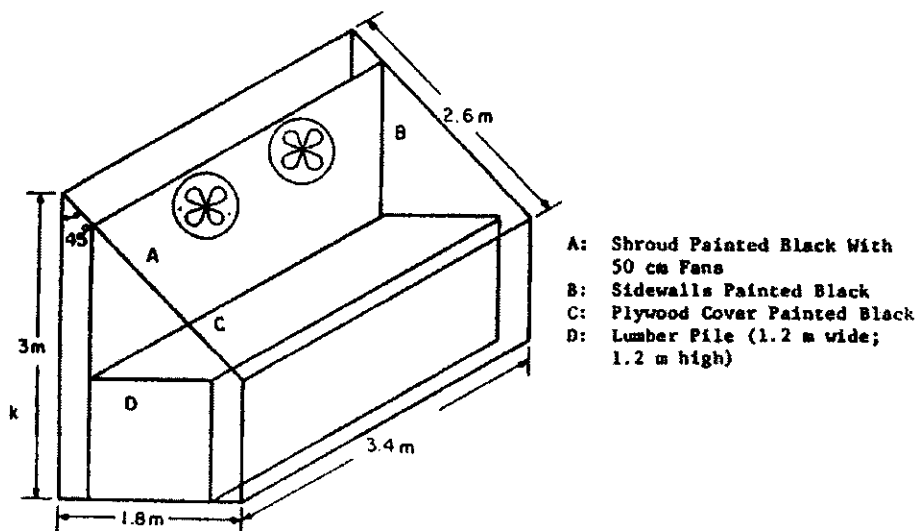
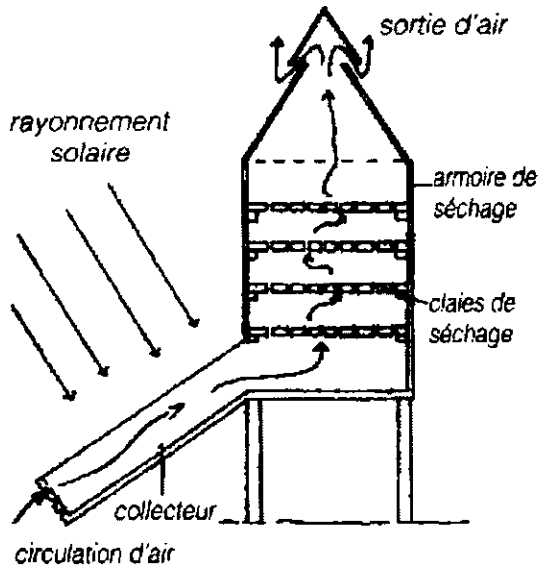

Fig II.4 The hut solar dryer**II.4 Indirect solar dryers [5] ,[6]**

These systems are more effective than direct dryers, and have the benefit of better preserving the food's characteristics: its color, texture, nutritional value. Therefore they are particularly suited to drying food products.

II.4.1 Working principle

The indirect solar dryer is composed of parts: a collector converting solar radiation into heat, a drying chamber containing the product and a chimney. The air flows into the collector; it is heated and the temperature increases. The hot air elevates to the drying chamber through natural convection. The drying period depends on climatic conditions.

**Fig II.5** The indirect solar dryer**II.4.2 Advantages**

- The product is not exposed to direct sunlight. It better retains its color and nutritional value (especially vitamins A and C).
- Possibility to build dryers of this type locally, at a reduced cost.
- Their operation does not require electrical energy or fossil fuels.

II.4.3 Disadvantages

- Very variable speed of drying depending on climatic conditions and the design of the dryer.
- Fragility of polyethylene materials that must be changed regularly.

II.4.4 Indirect dryer type**II.4.4.1 The cabinet solar dryer**

The collector collects solar energy. The hot air rises to the drying chamber where the products are placed on stacked racks. The cabinet dryer is made up of a solar collector whose interior has been blackened and a drying chamber containing superimposed racks. The collector is covered with translucent plastic sheet and ensures the production of hot air. The drying chamber protects the products from the sun, also preserving their quality. The drying chamber protects the products from the sun, also preserving their quality.

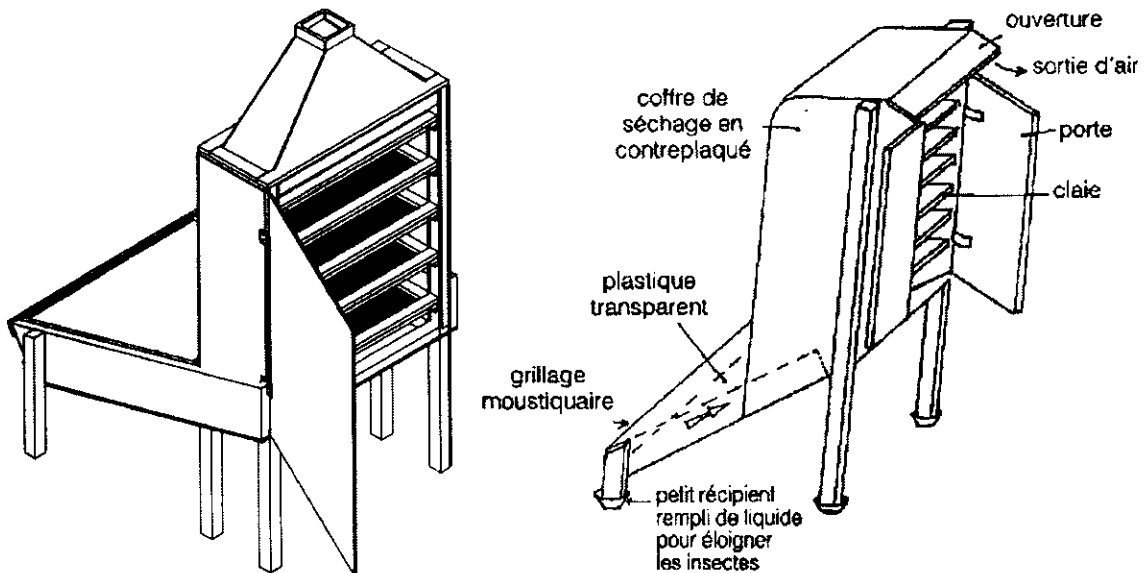

Fig II.6 The cabinet solar dryer

II.5 Hybrid dryers

Research has focused on hybrid dryers using additional energy: fuel, electricity, wood, gas ... the additional energy input can be located in two different places of the dryer.

Maintain a steady temperature of a gas burner or electric resistance or wood fire in the dryer. In this case solar energy becomes secondary, it actually permits preheating of the air.

Increase in air circulation by electric fans, here solar energy remains the source of heat but, thanks to better ventilation, the dryer has a greater capacity for evaporation.

II.4.1 Advantages

- Postage in relation to climatic conditions.
- Better drying control.
- Significant increase in output compared to other forms of solar dryers. since if necessary the system will run at night or during the rainy season.

II.4.2 Disadvantages

- High cost of production and of investment.
- Need for diesel, electricity, spare parts.
- Skilled Repair workers

II.4.3 Types of hybrid dryers

II.4.3.1 Hybrid forced convection dryer

II.4.3.1.1 Working principle

The building's roof is used to capture, a ventilator ensures sufficient air ventilation the products the goods to dry very quickly.

II.4.3.1.2 Technical description :

A fan draws air in from inside the building and passes through a solar collector in the building's roof. In the drying chamber the heated air arrives where the fruits are placed on superimposed racks.

II.4.3.1.3 Advantages

- Very efficient dryer.
- Easily convertible into a building

II.4.3.1.4 Disadvantages

- Need large quantities of fruit to be profitable year round

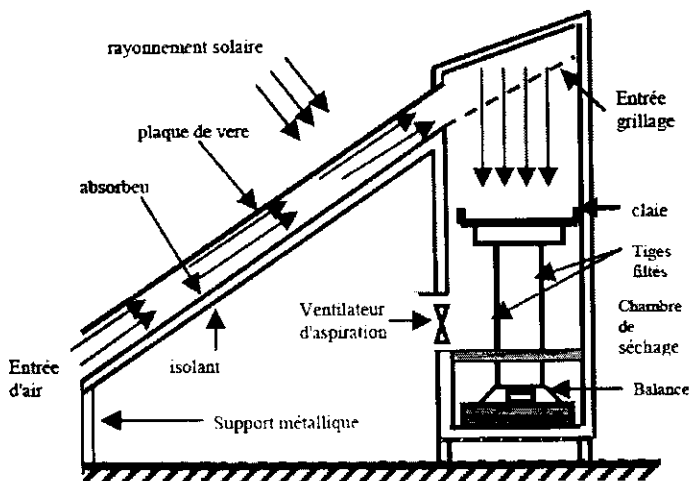

Fig II.7 Hybrid forced convection dryer

II.4.3.2 Hybrid dryer solar-gas

II.4.3.2.1 Working principle

Using the solar collector for preheating the air. If the temperature is inadequate, a gas burner is activated to get the temperature that is required. Therefore The products will dry out whatever the weather conditions.

II.4.3.2.2 Technical description :

Air movement from the solar collector to the cabinet occurs through natural convection. The gas burner helps to obtain the requisite temperature to dry the products properly whatever the climatic conditions.

II.4.3.2.3 Advantages

- Fast drying and of excellent quality.
- Temperature control.
- Very high productivity.

II.4.3.2.4 Disadvantages

- Quite high investment costs.
- Need to have a large market to be able to sell the products.

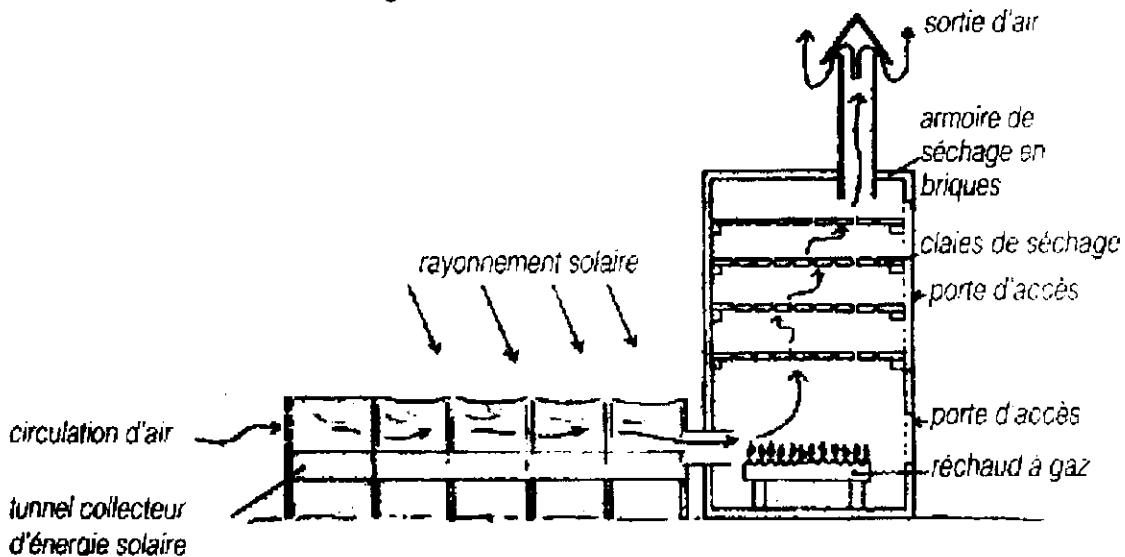

Fig II.8 Hybrid dryer solar-gas

II.6 Mixed dryer

These dryers combine the devices of direct and indirect dryers. In this type of dryer, the combined action of direct solar radiation on the product to be dried and the solar collector is to provide the heat necessary for the drying process. A mixed dryer with natural circulation would have the same structuring devices as an indirect dryer (solar collector, drying chamber, and a chimney) but the walls are fitted with glass plates so that solar radiation encroaches directly on the product as the integral dryer.

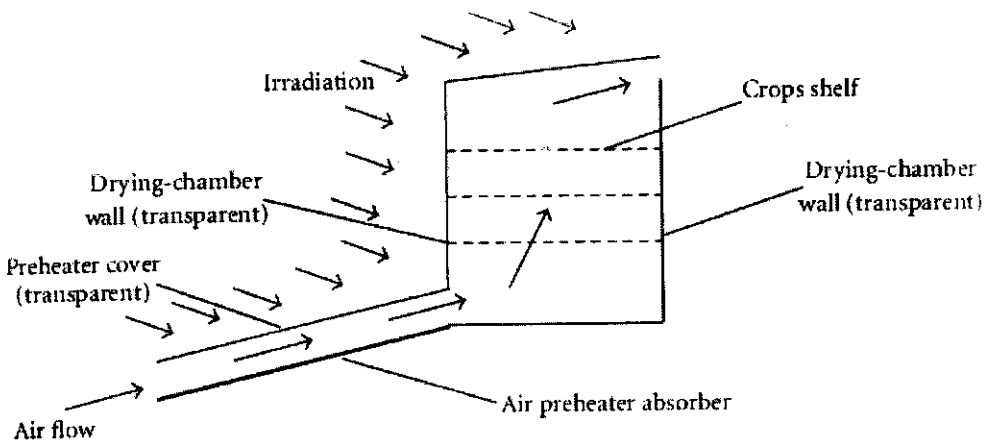

Fig II.9 Mixed dryer

II.7 Solar collectors [12]

II.7.1 Photovoltaic solar collectors [10]

The solar collector also called solar panel is a device designed to absorb the sun's rays to transform them into solar energy. To facilitate its installation and the capture of solar flux, the solar collector is most often in the form of a flat panel.

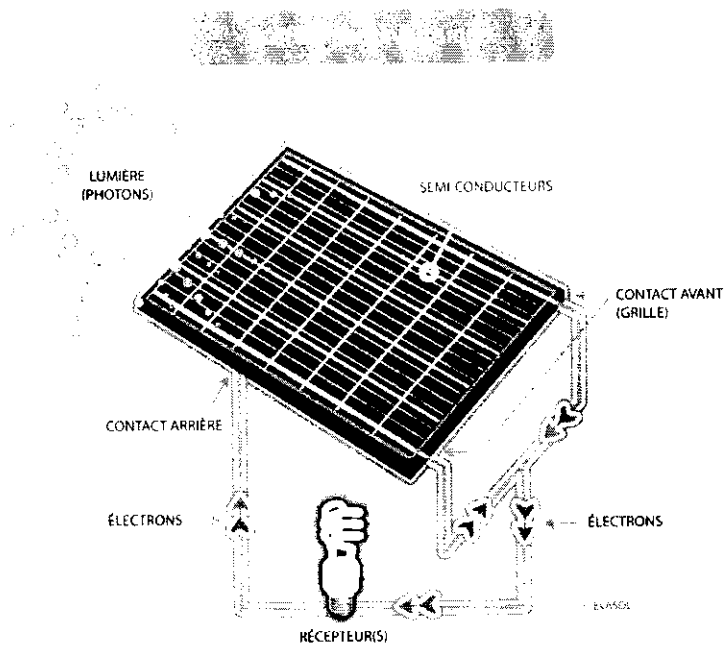

Fig II.10 Photovoltaic panels [13]

II.7.2 Thermal solar collectors

II.7.2.1 Solar collectors without concentration (stationary)

▪ Parabolic cylindrical concentrator [8]

It is by far the most mature industry. These plants use 100 to 800 m² parabolic cylindrical mirrors which concentrate the sun's rays on tubes placed at the focal axis of the concentrator and in which a heat transfer fluid circulates. The concentrator follows the course of the sun by rotating on an axis. The heat transfer fluid, generally a synthetic oil, heated as it passes through the tubes, circulates through a series of heat exchangers to produce superheated steam at a temperature of 390° C under a pressure of 100 bars

Collecteurs cylindro-paraboliques

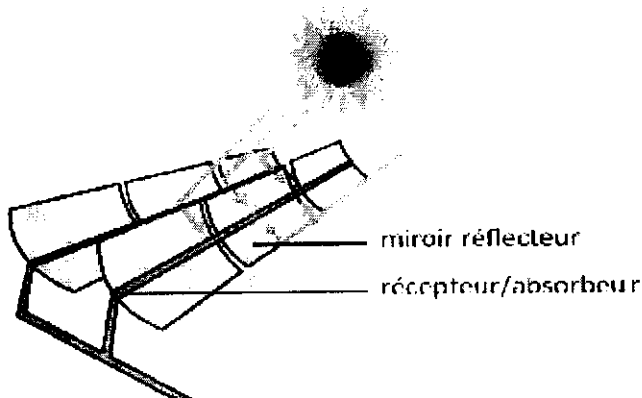

Fig II.11 Parabolic cylindrical concentrator

▪ Parabolic solar dish concentrator [7]

Another type of concentrating solar collector that optically reflects and focuses the sun's incident solar energy onto a small receiving area using mirrors or lenses is called a Solar Dish Collector, or more technically, a point focusing collector. By concentrating the sunlight to a single spot, the intensity of the receiving solar energy is magnified many times over with each mirror or lens acting as a single sun shining directly at the same focal point on the dish meaning that more overall power per square meter of dish is achieved.

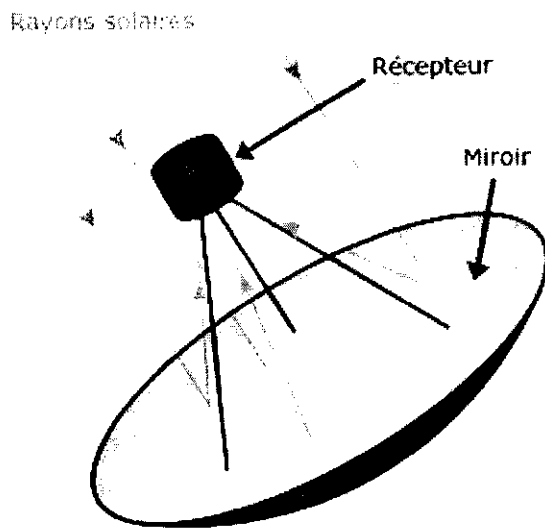

Fig II.12 Parabolic solar dish concentrator

II.7.2.2 Flat solar collectors [13]

The absorber sheet absorbs up to 95% of available sunlight converting into usable heat for hot water production. The flat plate solar thermal collector is suitable for residential or commercial solar water heating projects. The flat plate collector features a low profile design (80mm / 3.15" profile), which combined with ultra-lightweight melamine foam insulation, makes it one of the lightest flat plate panels per m² on the market.

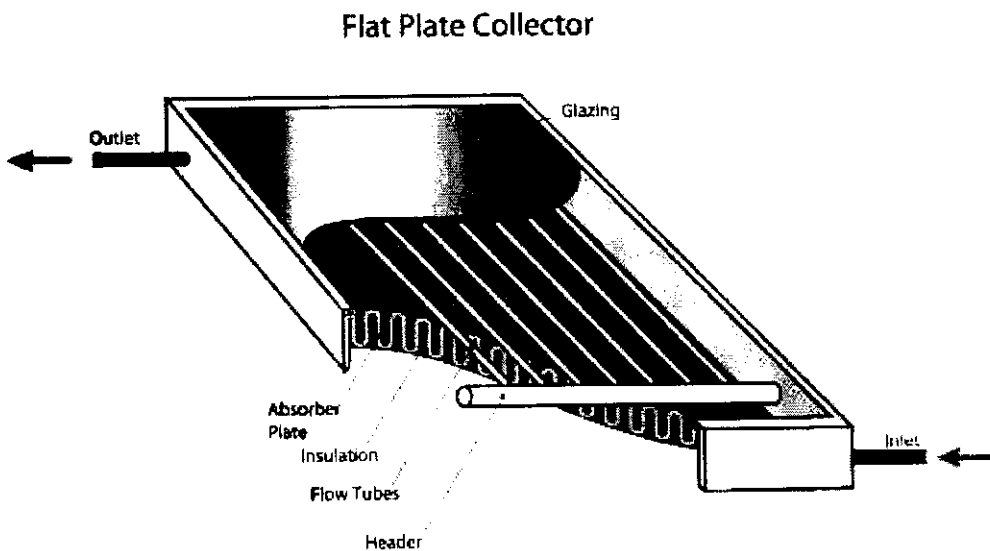

Fig II.13 Flat solar collectors

II.8 Conclusion

In this chapter we conclude that the solar dryers divided by four types: Direct solar dryers, indirect solar dryers, hybrid solar dryers, and mixed solar dryers. And collectors divided into two types; Photovoltaic solar collectors and thermal solar collectors (planar collectors, concentration collectors) Where the drying of agricultural products is subject to dryer mode and type of collector.

1. Introduction

In this chapter we study the products that we are going to dry and the methods of their preparation in addition to the tools and materials used for drying.

III.2 Preparation of the products to be dried

III.2.1 Banana

Bananas are very generally sterile fruits from domesticated varieties. Only the fruits of wild bananas and a few domestic cultivars contain seeds. Bananas are usually yellow with brownish spots when they are ripe and green when they are not. Bananas are an essential part of the diet in some regions, such as Uganda, which is said to offer around fifty varieties of this fruit.



Fig III.1 Bananas

▪ Recommended preparation steps

1. Washing
2. peeling
3. washer cut
4. Pre-treatment before drying advises. A choice :
 - ✓ Soaking 5 hours in water with lemon juice (juice of one lemon / liter of water)
 - ✓ Soaking 5 hours In a sugar solution (700 g / liter of water) and containing lemon juice (juice of one lemon / liter of water)



Fig III.2 Soaking washer cut of bananas in water with lemon juice

■ **Drying parameter**

Initial water content	70%
Recommended final water content	15%
Maximum temperature	70%
Drying report	1/10 for drying without prior soaking 1/5 for drying with pre-soaking

■ **Conservation**

The shelf life of dried banana slices does not exceed one year

■ **Advice for consumption**

1. Use as is as a snack product
2. Use after soaking for 30 minutes as a pastry garnish

■ **Observation**

1. Pre-soaking is recommended because drying the banana is difficult to achieve: the product turns brown very easily.
2. The preliminary soaking in a sweet solution improves the taste which is similar to the fresh banana, and easy conservation
3. Lemon juice can be replaced by a solution of metabisulphite at the rate of 3 g of metabisulphite per liter of water used.

III.2.2 Potato [15]

the potato is an edible tuber produced by the species *Solanum tuberosum*, belonging to the nightshade family. is an a starchy tuber vegetable that grows underground and has white flesh with light brown, red, or pink skin. As shown in the following figure.



Fig III.3 Potato

- **Recommended preparation steps**

1. Washing
2. peeling
3. Cutting
 - ✓ In thin slices 3 to 5 mm thick
 - ✓ French fries
4. Recommended pre-treatment, optional:
 - ✓ Blanch for 9 minutes in boiling salted water
 - ✓ Blanching for 5 minutes in boiling water then soaking for 1 minute in a solution of 8g / liter of water

- **Drying parameter [16]**

Initial water content	75%
Recommended final water content	13%
Maximum temperature	70%
Drying report	1/7
End of drying criteria	crispy and brittle product

- **Conservation**

The shelf life of dried potato slices does not exceed 4 to 6 months.

- **Advice for consumption**

1. Soak before use.
2. You can brown the potatoes and / or cook.

- **Observation**

1. Drying can be done without pretreatment, but the potatoes turn black.

III.3 Equipment used

III.3.1 Solar dryers assisted by parabolic cylindrical collector

The solar dryer coupled by parabolic trough is composed of three essential parts, a parabolic trough solar reflector, a drying chamber and a receiver and other less important parts figure following.

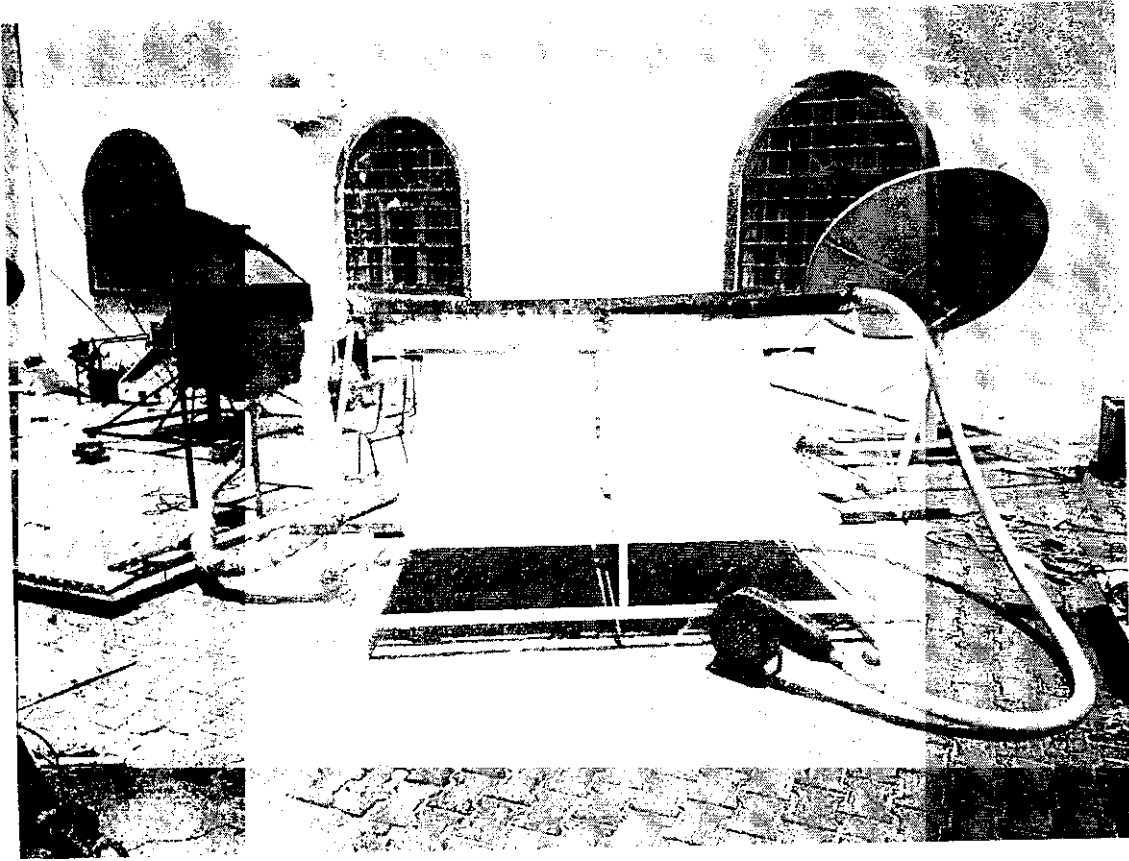

Fig III.4 Solar dryers

III.3.2 Collector

The parabolic collector is a type of solar thermal energy collector, the technical and economic performance is the successful production of the mirror panels of very good quality with a reflector of 94%.

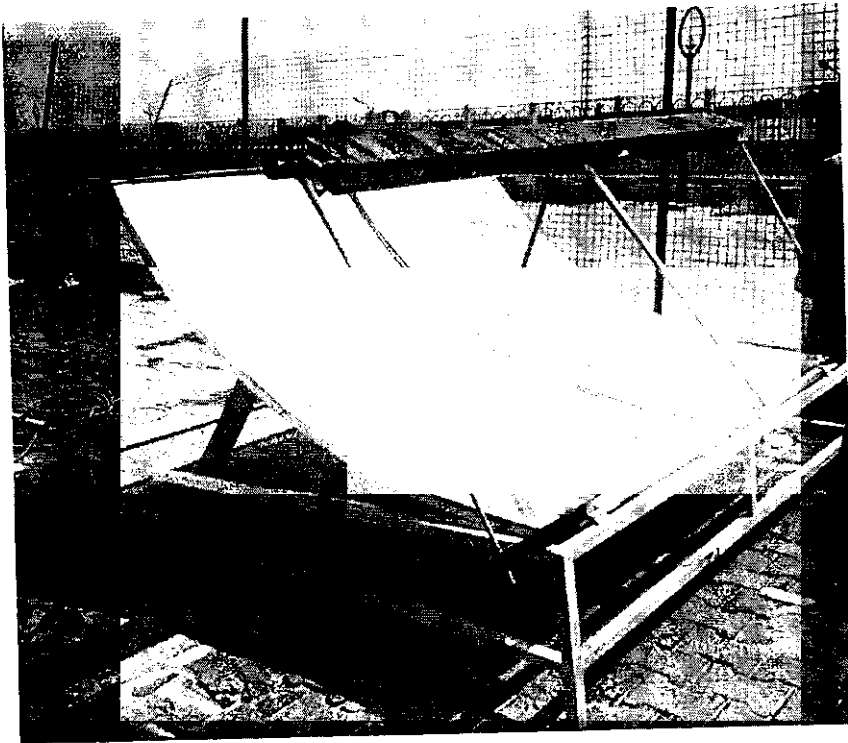

Fig III.5 Collector

III.3.3 The receiver

The parabolic trough concentrator receiver in prismatic form over the entire length of the reflector. The receiver metal must have good conductivity, we have chosen iron (whose thermal conductivity is around 80 W / k.m^2), the receiver absorbs the radiation concentrated on a black surface and transforms the heat generated to the drying air, the receiver contain inside has obstacles to let the air stay longer for the well heated.



Fig III.6 Receiver

III.4 Measuring instruments

III.4.1 Temperature measurement

To measure the temperature in several point of solar dryer (receiver, drying chamber, room temperature) use the 12 channel temperature recorder.



Fig III.7 Temperature recorder

III.4.2 Weight measurement

The electronic scale used to measure the weight of the sample has the necessary efficiency that allows us to follow the weight until the last drying process where the decrease in the weight of the sample is very slow.

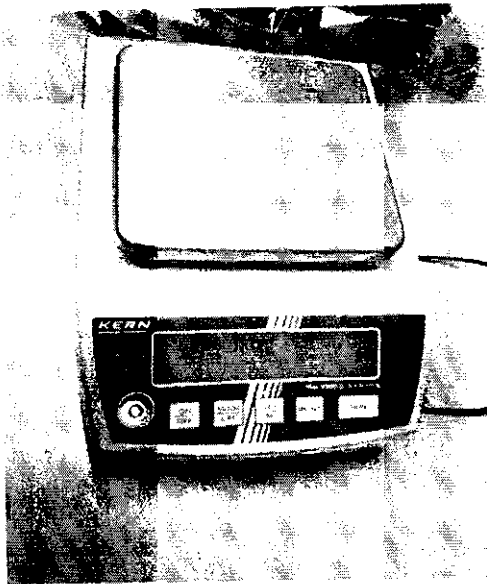

Fig III.8 Electric scale

III.4.3 Solar radiation measurement

Solar power meters are instruments designed to measure sunlight in a particular area. This information can be used to consider how productive a solar panel or other solar powered device may be in a particular place.



Fig III.8 Solar power meter

III.5 conclusion

By using this equipment in addition to the measuring instruments that we have discussed in this axis, we can acquire all the parameters of the drying experience.

IV.1 Introduction

In this chapter, we will draw the drying experience curves, which are the water content in terms of drying time, solar radiation in terms of drying time, after drawing these curves, we comment and discuss them.

IV.2 Banana drying curves

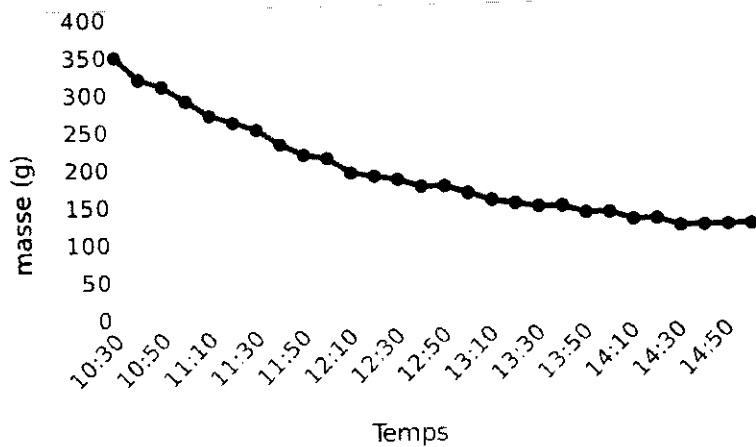

Fig IV.1 Variation of mass as a function of time

The previous image shows a relative decrease between mass and water content, when a decrease in the amount of water content from 3.45 ($\text{g}_{\text{eau}} / \text{g}_{\text{ms}}$) to zero and a decrease in mass also of 350 grams to 79 grams in 3 hours. The weight loss is rapid at the start of drying, because the substance contains a significant amount of water estimated at 75%. The mass continues to decrease, but this decrease decreases in intensity with time.

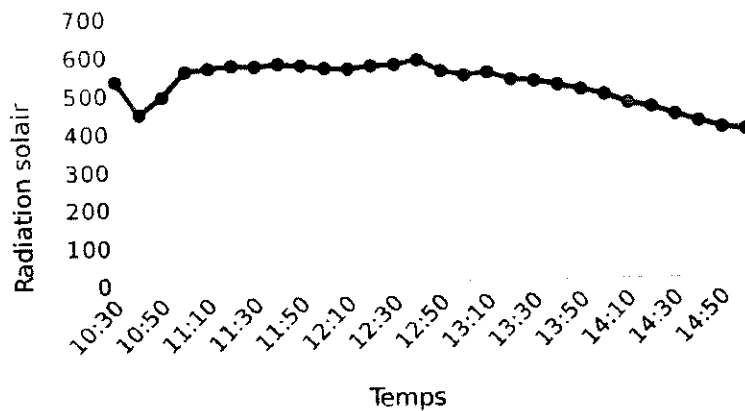
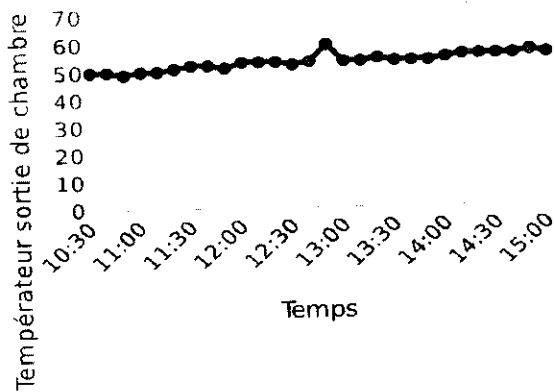

Fig IV.2 The intensity of solar radiation as a function of time

The previous image shows the intensity of solar radiation as a function of time, the solar radiation was at its peak after 40 minutes had decreased slightly, and this was due to the passage of the clouds, after which it returned to what it was, only to return after the meridian to gradually decrease.

Through the corresponding temperature curves, we notice that there is a difference between the inlet temperature in the drying chamber and the outlet temperature. This is normal, but the difference was small, and this is one of the shortcomings of the experiment, due to the speed of the air driven by the use of the fan .



(a)

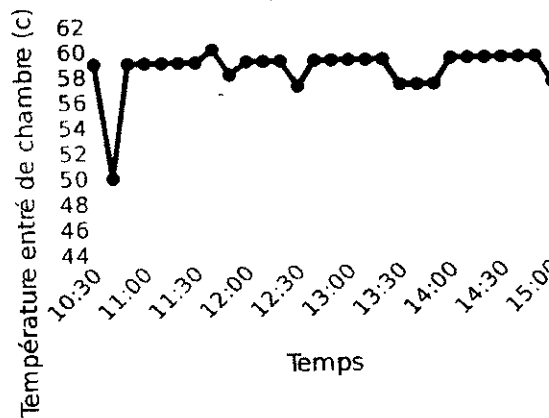

(b)

Fig IV.3 Inlet and outlet temperature of the drying chamber as a function of time (a)

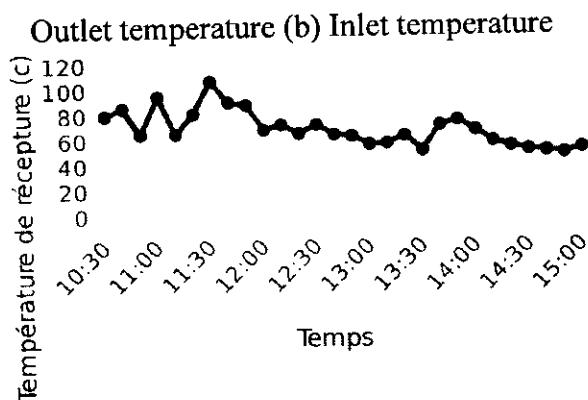

Fig IV.3 The receiver temperature as a function of time

The maximum temperature for the receiver was 107 ° C. This temperature is along the length of the receiver, which is 2 meters.

IV3 Conclusion

We performed several locally designed solar dryer experiments at Eloued University, and the previous results were similar to the banana experiment, which lasted about five hours. The results are satisfactory, but the difficulty in manufacturing and handling the dryer makes it expensive.

General conclusion

Our work includes an experimental study of the solar drying of bananas and potatoes by forced convection of hot air supplied by an indirect solar dryer assisted by a cylindrical parabolic collector. The hot air is transferred through the tube to the aluminum drying room and the wood is well thermally insulated.

Our experimental part is based on drying using indirect solar thermal energy to dry the products, This process (sun drying) is followed during the day to give results in the form of contrast curves for:

Drying speed, drying chamber temperature, ambient temperature and water content change in these products

The main objective of these experiments is to use the free renewable energy (the sun) in to study the drying kinetics and the water content of these products. The results obtained in this study on bananas are as follows: temperature range desired to dry the banana from 65-75 ° C in 5 hours.

This study also leads us to the conclusion that the drying process works well during the early hours of the day (8 a.m. to 12 p.m.). That means he can't be for the rest of the day. Take into account the good insulation of the tube and the drying chamber to avoid heat leakage through the tube and the chamber.

Finally, this study shows that it is applied to a project in this area to dry the various consumed and dried products. Because drying is the best way to avoid the degradation of certain agricultural products harvested at very high value.

This project is economical (inexpensive) and its main source (the sun) is free.

- [1] Michel Kapderou 1988. Atlas solaire de l'Algérie tome 1 –modèle théoriques et expérimentaux - volume2.
- [2] Ministère de l'énergie et des mines. www.mem.algeria.org
- [3] Nadia Chalal étude d'un séchoir solaire fonctionnant en mode direct et indirect Mémoire de magister. (2007).Université Mentouri-Constantine .
- [4] D. Mennouche, Valorisation des produits agro-alimentaires et des plantes médicinales par les procédés de séchage solaire. Mémoire de magister. Université Kasdi Merbah Ouargla(2006).
- [5] N.Nadir, Recherche des conditions optimales de fonctionnement d'un séchoir solaire. Mémoire de magister, université Kasdi Merbah Ouargla(2009).
- [6] N.Chalal, Etude d'un séchoir solaire fonctionnant en mode direct et indirect. Mémoire de magister. (2007).Université Mentouri-Constantine.
- [7] <https://www.alternative-energy-tutorials.com/solar-hot-water/solar-dish-collector.html>
- [8] <https://www.edf.fr/sites/default/files/Lot%203/CHERCHEURS/Publications/technologie devoilee01internet.pdf>.
- [9] Busunia MA., Abc T.(2001) Characteristics of rough rice under natural convection. Journal of Food Engineering, 47, 295-301.
- [10] A, H, Khedim. Energie solaire et son utilisation sous forme thermique et photovoltaïque. Centre de Publication Universitaire. (2003).
- [11] N.Chalal, Etude d'un séchoir solaire fonctionnant en mode direct et indirect. Mémoire de magister. (2007).Université Mentouri-Constantine
- [12] Guide de l'utilisateur de Toit Solaire Photovoltaïque. Programme européen PV-SALSA (2002).
- [13] <https://www.calculo.fr/Eco-travaux/Panneaux-solaires-photovoltaiques/Les-capteurs-solaires>
- [14] H.Houhou, Etude théorique et expérimentale du séchage solaire de certains produits agro-alimentaires. Mémoire de magister. université Mohamed Khider – Biskra .
- [15] La culture de pomme de terre : Production et possibilité pour la transformation Journée de la Pomme de Terre. Institut Technique des Cultures Maraîchères et Industrielles. Mostaganem, (2013).
- [16] H.Medjoudj, Etude du comportement au séchage de six légumes : Carotte, Courgette, Cardon, Pomme de terre, Ail et Oignon. Mémoire de magister, Université Mentouri de Constantine.