

# Implementation of Perturb and Observe Based MPPT Algorithm for Photovoltaic System

GUIZA Dhaouadi

Department of Mechanical Engineering  
Skikda University  
Skikda, Algeria  
guiza12d@yahoo.fr

SOUFI Youcef

LABGET Laboratory, Department of Electrical Engineering  
Larbi Tebessi University-Tebessa,  
Tebessa, Algeria  
y\_soufi@yahoo.com

OUNNAS Djamel

LABGET Laboratory, Department of Electrical Engineering  
Larbi Tebessi University-Tebessa,  
Tebessa, Algeria  
djamel\_ounnas@hotmail.com

MAAMRI Mahmoud

LABGET Laboratory, Department of Electrical Engineering  
Larbi Tebessi University-Tebessa,  
Tebessa, Algeria  
mmaamri@gmail.com

**Abstract**—This paper presents the implementation of perturb and observe (P&O) maximum power point tracking (MPPT) for a photovoltaic system which consists of PV panel, DC-DC Boost converter controlled by an Arduino microcontroller based unit and resistive load. The proposed system has high efficiency, lower cost and can be easily modified to handle more energy sources. The experimental results indicate that the use of the considered MPPT control increases the PV output power; hence increases the overall PV system efficiency.

**Index Terms**—Perturb and Observe , MPPT, Arduino Board.

## I. INTRODUCTION

The photovoltaic power systems are one of the fastest growing renewable energy technologies, providing more secure power sources and pollution free electric supplies. Unfortunately, PV systems have two major drawbacks: low efficiency of energy conversion and its nonlinear characteristics, which depend on the irradiation and temperature conditions. Therefore, to extract maximum power from the PV module, it is necessary to determine its operating point that provides the maximum power output from the photovoltaic panels [1], [2].

An MPPT system is used to extract the maximum power from the PV module using boost converter as an interface between the PV module and load to transfer the maximum power of the photovoltaic system to the load.

Maximum power is transferred by changing the load impedance as seen by the source and matching it at the peak power of it when the duty cycle is varied. In order to maintain PV module's operating at its MPP, different MPPT methods are studied, [3]. In the literature, many MPPT methods are proposed such as the including constant voltage, hill climbing, short circuit current, open-circuit voltage, perturb and observe (P&O) method, incremental Conductance (IC) method, Fuzzy Logic Method etc... [4]– [9].

However, one algorithm, the perturb and observe claimed by many methods and continue to be by far the most common MPPT method used in practice because it is simple structure

and ease of implementation [10], [11], and [12]. This paper presents a practical implementation of P&O algorithms based on Arduino microcontroller for tracking of the maximum power generation from PV system under a rapid change in the radiation level. The proposed control system algorithm obtains the data from the PV system through microcontroller's Analog and Digital ports to perform the PWM (pulse width modulation) to the DC-DC converter.

## II. PHOTOVOLTIC SYSTEM MODELING

The considered PV system is composed of DC (Direct Current) load , DC/DC boost converter and PV panel, as shown in Fig. 1. In this study, the following PV system parameters will be used:

- $V_{PV}$  and  $i_{PV}$  are the PV output voltage and current, respectively.
- $i_L$ ,  $i_o$ ,  $V_o$  and  $u$  are the boost self-inductance current, output load current, output load voltage and control input corresponding to the duty cycle, respectively.
- $C_1$ ,  $C_2$ ,  $L$ ,  $R_L$  and  $v_d$  are the input capacitor, output capacitor, boost inductance, resistance of self-inductance and diode's forward voltage, respectively.

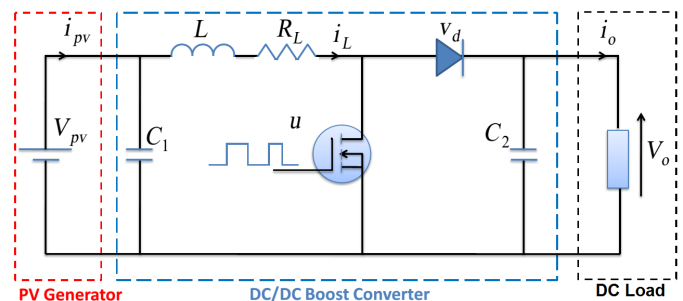

Fig. 1. Photovoltaic system.

### A. PV panel model

The PV output current is given by [16]:

$$i_{PV} = n_p I_{ph} - n_p I_s \left( \exp \left[ \frac{q(V_{PV} + R_s i_{PV})}{kTA} \right] - 1 \right) - \frac{V_{PV} + i_{PV} R_s}{R_{sh}} \quad (1)$$

where  $I_{ph}$  and  $I_s$  represent the light-generated current and cell saturation of dark current.  $R_s$  and  $R_{sh}$  are the cell series and shunt resistances.  $q$ ,  $k$ ,  $T$ ,  $n_p$  and  $A$  are the electron charge, Boltzmann constant, cell temperature, number of parallel solar cells and the ideal factor, respectively.

The light-generated current depends on solar irradiation and cell temperature with the following expression:

$$I_{ph} = G (I_{sc} + K_I (T - T_r)) \quad (2)$$

where  $I_{sc}$  represent the cell short-circuit current at 25 °C and 1 kW/m<sup>2</sup>.  $K_I$ ,  $T_r$  and  $G$  are the the cell short-circuit current temperature coefficient, cell reference temperature and solar irradiation in kW/m<sup>2</sup>, respectively. On the other hand, the saturation current depends on cell temperature with the following expression:

$$I_s = I_{rs} \left( \frac{T}{T_r} \right)^3 \exp \left[ \frac{qE_g}{kA} \left( \frac{1}{T_r} - \frac{1}{T} \right) \right] \quad (3)$$

where  $E_g$  is the band-gap energy of the semiconductor used in the cell and  $I_{rs}$  is the reverse saturation current given by:

$$I_{rs} = \frac{I_{sc}}{\exp \left[ \frac{qV_{oc}}{n_s k A T} \right] - 1} \quad (4)$$

where  $V_{oc}$  is the open-circuit voltage.

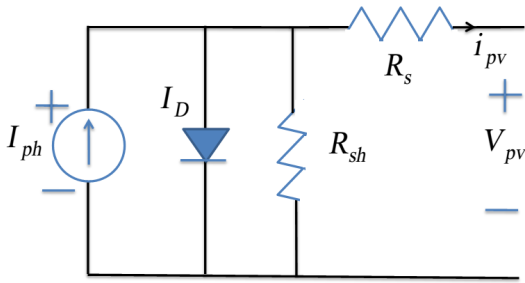

Fig. 2. Electrical Equivalent schema of PV panel

The power-voltage and current-voltage characteristics illustrated in Fig. 3 shows that the variation of the maximum power of PV panel, highly changes as a function of the solar irradiation and cell temperature. The PV conversion system parameters are given in table I.

A detailed Simulink modeling of the PV module has been discussed in [13], [14]. The dimension of the PV module is found to be 668 mm 528 mm 28 mm, and its electrical specification is presented in Table 1 [15].

The characteristic of an PV module under the standard irradiation and temperature conditions is shown in Fig. 3.

TABLE I  
PV CONVERSION SYSTEM PARAMETERS.

Rated power	70W
Voltage at MPP (VMPP)	16.7V
Current at MPP (IMPP)	4.2
Open-circuit voltage (VOC)	21.3
Short-circuit current (ISC)	4.5
Number of cells connected in series (NS)	36
Number of cells connected in parallel (Np)	1

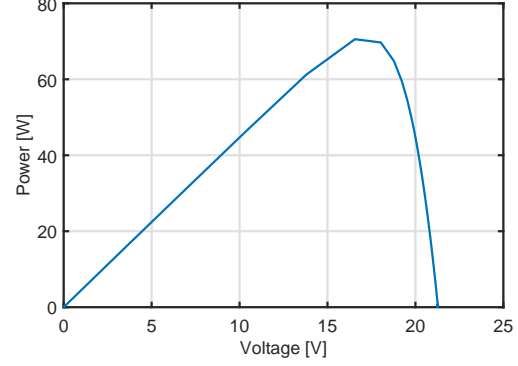

(a) power-voltage characteristic

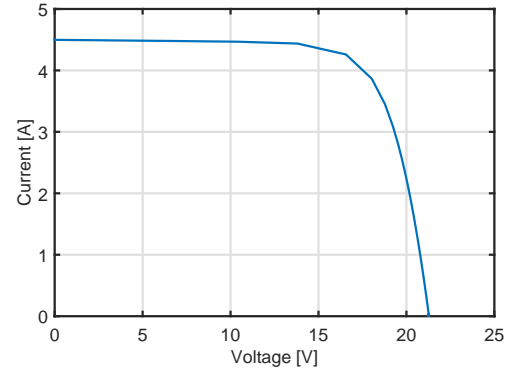

(b) current-voltage characteristic

Fig. 3. Nonlinear characteristic of PV panel

### B. DC-DC Boost converter

A DC-DC boost converter configuration has been used for this research. It simply scales down the output of the PV panel to the desired level. As shown in Fig. 1, it consists of a controllable switch power MOSFET, a diode (D), an inductor (L) and a filter capacitor (C). The component values of the considered dc-dc boost converter are given in Table II.

### C. P&O MPPT method

In order to increase the efficiency and to maintain the operating point at an optimum maximum power point of the PV power generation system, Maximum Power Point Tracking (MPPT) is used to track the new modified maximum power point in its corresponding curve whenever there is a variation in the temperature or irradiation and to keep maintain this

TABLE II  
COMPONENT VALUES OF DC-DC BOOST CONVERTER.

MOSFET	IRFZ44N
Diode	BYT30P-1000
Inductor	180uH
Capacitor	100uF
Load resistor	10Ω
Switching frequency	62KHz

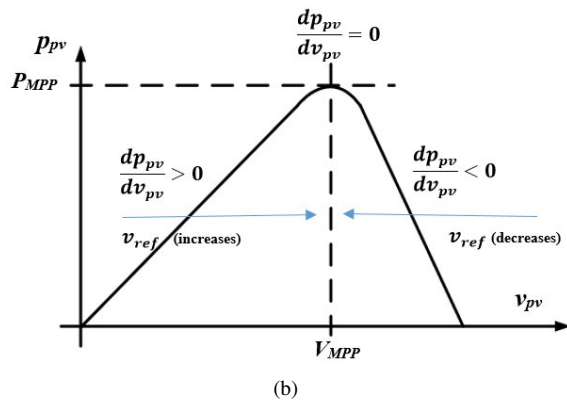
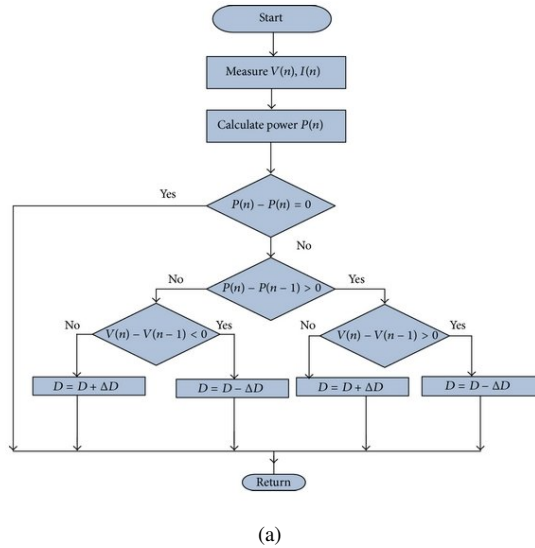

Fig. 4. (a) Flow chart of P&O algorithm, (b) P-V characteristic of PV panel.

point at an optimum value a power conditioner or a DC-DC converter is added as an interface between the PV generator and the load. It extracts the maximum power from the source and transfers it to the load by stepping up (boost) or stepping down (buck) as per the requirement at the load side. The power transfer is carried out in accordance to the maximum power value by varying the on/off duty cycle of switch of the DC-DC converter [17].

The P&O method is widely used in MPPT, because it has a fewer measured parameters. It can track maximum power point quite accurately through variations in radiation and temperature. It operates by perturbing the system by increasing or decreasing the panel operating voltage and observing the

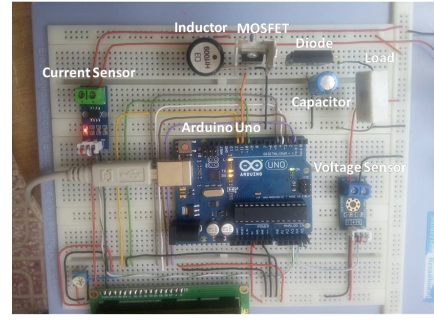

Fig. 5. Hardware implementation using arduino uno

impact of this change on the panel output power. Fig. 4 (a) is a flow chart of the P&O algorithm. As shown in Fig. 4 (b), if output power has increased, panel voltage is adjusted in the same direction as in the previous cycle. If the output power had decreased, panel voltage is perturbed in the opposite direction as in the previous cycle. When the maximum power point (MPP) is reached, the output voltage will oscillate around the maximum operation voltage [18].

### III. SIMULATION AND EXPERIMENTAL RESULTS

The experimental configuration is illustrated in Fig. 5. The arduino uno board is used as the interface between the hardware and the simulink control model. The voltage and current sensors are used to measure the PV output voltage and PV output current. The simulink model of the algorithm generates the PWM required by the MOSFET.

The hardware implementation of the MPPT algorithm is performed using an arduino uno board, which is based on an atmega 328p microcontroller. It is operated at 5V supply and a built in 10 bit Analog/Digital converter. This microcontroller chip consists of six analog input pins and six digital PWM pins. The controller runs on 16 mHz frequency.

The microcontroller takes the module voltage and current as inputs and the PWM signals as outputs, in order to control the boost converter for tracking the MPP. The Arduino board is interfaced with Matlab using the Arduino Input/Output (I/O) Package. This software helps to read and display the experimental results.

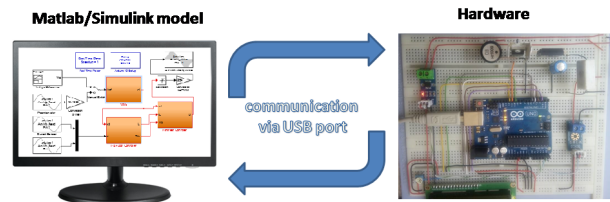

Fig. 6. Communication with an arduino board using matlab I/O package.

The experiments were conducted on may 24th, 2018 under varying atmospheric conditions, the temperature was 27c and the solar irradiation varied between 874 and 969  $w/m^2$ .

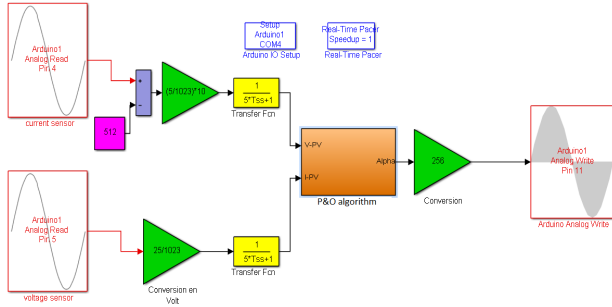
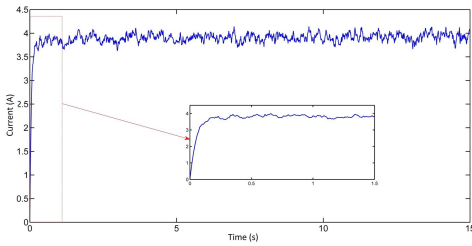
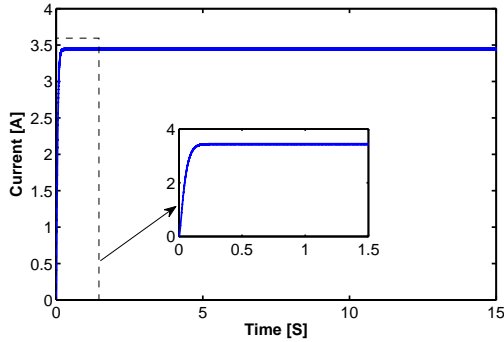

Fig. 7. Simulink model using matlab I/O package



(a) Experimental result



(b) Simulation result

Fig. 8. Response of PV current

The responses of PV output current voltage, PV output voltage and PV output power are shown in Fig. 8, Fig. 9 and Fig. 10, respectively. As it can be observed, the steady states follow perfectly the optimal trajectories and are not affected by the solar irradiation and cell temperature variations. This leads to an important extraction of the available solar power and an improved performance of the system.

The practical results demonstrate that PV system can be controlled perfectly by the considered P&O method.

#### IV. CONCLUSION

The PV solar module output power carried to a load can be maximized using MPPT control system, which consist of

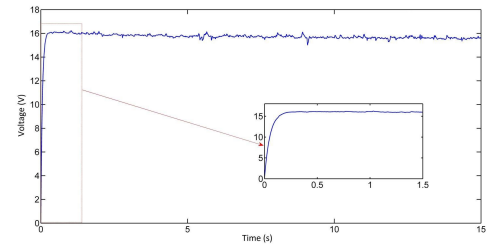

(a) Experimental result

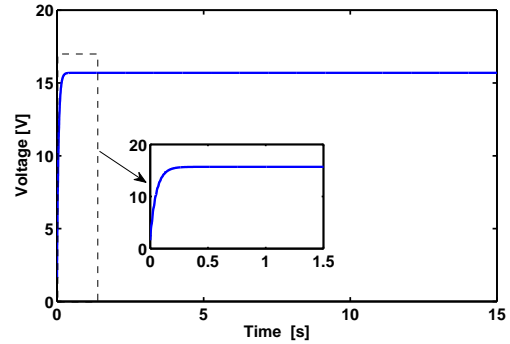

(b) Simulation result

Fig. 9. Response of PV voltage

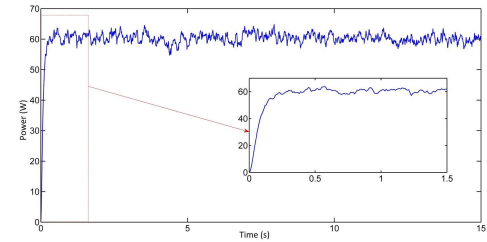

(a) Experimental result

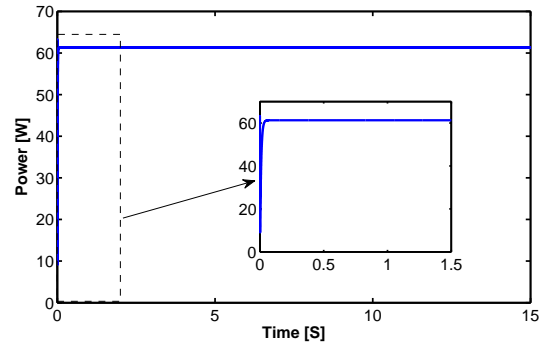

(b) Simulation result

Fig. 10. Response of PV power

a power converter to interface the photovoltaic output to the load, and a control unit, which drives the power converter such that it extracts the maximum power from a PV solar module. In this study, a P&O MPPT algorithm for the PV system was implemented using a DC–DC boost converter and the Arduino

microcontroller to control the PWM signal of the converter for achieving MPPT. The hardware setup was implemented and tested and was found to work satisfactorily. The practical results demonstrate that PV system can be controlled perfectly by the considered P&O method.

#### REFERENCES

- [1] I. Idris, M. S.Robian, A. K. Mahamad, and S. Saon, , "Arduino based maximum power point tracking for photovoltaic system," *ARNP Journal of Engineering and Applied Sciences* , vol. 11, pp. 8805–8809, 2016.
- [2] M. Diner, and A. Isik , "Effects of thermoplastic retainers on occlusal contacts," *The European Journal of Orthodontics*, vol. 32.1, pp. 6–10, 2009.
- [3] Ch. Kumar, T.Kiran, Dinesh, and S. Ganesh Babu, "Design and Modelling of PV system and Different MPPT algorithms," *International journal of engineering Trends and technology (IJETT)* , vol. 4.9, pp. 4104–4112, 2013.
- [4] H. Bounechba, , A.Bouzid, , H. Snani, , and A. Lashab, "Real time simulation of MPPT algorithms for PV energy system," *International Journal of Electrical Power and Energy Systems* , vol. 83, pp. 67–78, 2016.
- [5] Y. P.Huang, and S. Y. Hsu, "A performance evaluation model of a high concentration photovoltaic module with a fractional open circuit voltage-based maximum power point tracking algorithm," *Computers & Electrical Engineering* , vol. 32.51, pp. 331–342, 2016.
- [6] J. A. Cortajarena, O. Barambones, P.Alkorta, and J. De Marcos, "Sliding mode control of grid-tied single-phase inverter in a photovoltaic MPPT application," *Solar Energy* , vol. 155, pp. 793–804, 2017.
- [7] A. Tobn, J. Pelez-Restrepo, J. Villegas-Ceballos, S. I. Serna-Garcs, J.Herrera, and A. Ibeas, "Maximum power point tracking of photovoltaic panels by using improved pattern search methods," *Energies* , vol. 10.9,1316, 2017.
- [8] A. Loukriz, M.Haddadi, and S. Messalti, "Simulation and experimental design of a new advanced variable step size Incremental Conductance MPPT algorithm for PV systems," *ISA transactions* , vol. 62, pp. 30–38, 2016.
- [9] A. Mellit, H.Rezzouk, A. Messai, and B. Medjahed, "FPGA based real time implementation of MPPT controller for photovoltaic systems," *Renewable Energy*, vol. 36.5, pp. 1652–1661, 2011.
- [10] M. A. Husain, M. F. Jalil, M. T. S. Beg, M. Naseem, and A. Tariq, "Modeling and study of a standalone PV system using MATLAB/SIMULINK,"*i-managers Journal on Power Systems Engineering* , vol. 5.4, pp. 30–36, 2012.
- [11] S. Nema, R. K. Nema, and G. Agnihotri, "Matlab/simulink based study of photovoltaic cells/modules/array and their experimental verification," *journal of Energy and Environment* , vol. 1.3, pp. 487–500, 2010.
- [12] T. Salmi, M.Bouzguenda, A. Gastli, and A. Masmoudi, "Simulink based modeling of photovoltaic cell," *International Journal of Renewable Energy Research (IJRER)* , vol.2.2, pp. 213–218, 2012.
- [13] N. Pandiarajan, R. Ramaprabha, and R. Muthu, "Application of circuit model for photovoltaic energy conversion system,"*International Journal of Photoenergy* , vol.2012, 2012.
- [14] M. R. Khan, A. Ilyas, and M. Ayyub, "Comparative Study of Equation Based and Model Based Photovoltaic System," *i-Manager's Journal on Power Systems Engineering*, vol. 3.1, 2015.
- [15] R. W. Erickson, and D. Maksimovic, " *Fundamentals of power electronics*," Springer Science and Business Media, 2007.
- [16] D.Ounnas, M.Ramdani, S. Chenikher and T.Bouktir, " Efficient Maximum Power Point Tracking Controller for Photovoltaic Systems Using TakagiSugeno Fuzzy Models," *Arabian Journal for Science and Engineering*, vol. 42.12, 2017.
- [17] S. Saravanan, , and N. R. Babu, " Maximum power point tracking algorithms for photovoltaic system," *Renewable and Sustainable Energy Reviews*, vol. 57, pp. 192–204, 2016.
- [18] J. Ahmed, and Z. Salam, " An improved perturb and observe P&O maximum power point tracking (MPPT) algorithm for higher efficiency," *Applied Energy*, vol. 150, pp. 97–108, 2015.