



**People's Democratic Republic of Algeria
Ministry of Higher Education
and Scientific Research**



Echahid Hamma Lakhdar University of El-Oued

FACULTY OF TECHNOLOGY

ELECTRICAL ENGINEERING DEPARTMENT

End of studythesis

Presented for obtaining the

ACADEMIC MASTER

Field: Sciences and Technologies

Specialty: Electrical Control

Presented by: Hezlaoui Abdelhak, Zegheb Mohammed, Mebarki Abdallah

Thesis

**Control and monitoring of irrigation Water
Pumping System by IoT**

Board of Examiners

Mr. Sliman Touil

Echahid Hamma Lakhdar University

President

Ms Madiha Maamir

Echahid Hamma Lakhdar University

Examiner

Ms. Hakima Cherif

Echahid Hamma Lakhdar University

Supervisor

2023-2024

Abstract:

The Internet of Things (IoT) is a multidisciplinary concept that includes a wide range of application domains and device capabilities. The IoT technology provides a platform that allows apparatus to be monitored by sensors connected using a communication channel, and controlled remotely across a network infrastructure. This project represents the IoT-based remote monitoring, control, and protection of irrigation water pumping systems. The sensors measure parameters; namely supply voltage and motor current to estimate operating conditions and provide protection.

The measured parameters are sent to the user through the SIM800L GSM module for remote monitoring and control purposes. Blynk android application has been developed to provide a better user interface, timer-based operation, status of pump and feedback notifications, etc. Protection to the pump (3- Φ Induction Motor) is provided through an ESP32 microcontroller. Appropriate relay characteristics are programmed in the microcontroller for protection against various types of faults like thermal overload, single phasing, under/over voltage, voltage imbalance, reverse rotation. The system is tested in the lab and it is observed that all the protections are working satisfactorily.

Keywords: Control, monitoring of irrigation Water, Pumping System, IoT.

Résumé:

L'Internet des objets (IoT) est un concept multidisciplinaire qui inclut un large éventail de domaines d'application et de capacités des appareils. La technologie IoT fournit une plateforme permettant aux appareils d'être surveillés par des capteurs, connectés via un canal de communication, et contrôlés à distance à travers une infrastructure réseau. Ce projet représente la surveillance, le contrôle et la protection à distance des systèmes de pompage d'eau d'irrigation basés sur l'IoT. Les capteurs mesurent des paramètres, à savoir la tension d'alimentation et le courant du moteur, pour estimer les conditions de fonctionnement et fournir une protection. Les paramètres mesurés sont envoyés à l'utilisateur via le module GSM SIM800L à des fins de surveillance et de contrôle à distance. Une application Android, Blynk, a été développée pour offrir une meilleure interface utilisateur, un fonctionnement basé sur un minuteur, l'état de la pompe et des notifications de retour d'information, etc. La protection de la pompe (moteur à induction 3- Φ) est assurée par un microcontrôleur ESP32. Des caractéristiques de relais appropriées sont programmées dans le microcontrôleur pour protéger contre divers types de défauts tels que la surcharge

thermique, le fonctionnement en une seule phase, les sous/surtensions, le déséquilibre de tension et la rotation inverse. Le système a été testé en laboratoire et il a été observé que toutes les protections fonctionnent de manière satisfaisante.

الملخص:

الإنترنت للأشياء (IoT) هو مفهوم متعدد التخصصات يشمل مجموعة واسعة من مجالات التطبيق وقدرات الأجهزة. توفر تكنولوجيا IoT منصة تسمح للأجهزة بأن تكون مراقبة بواسطة أجهزة الاستشعار، متصلة عبر قناة اتصال، ومتحكم بها عن بُعد من خلال بنية تحتية للشبكة. يمثل هذا المشروع المراقبة، والتحكم، والحماية عن بُعد لأنظمة ضخ مياه الري المعتمدة على IoT. تقوم أجهزة الاستشعار بقياس المعلمات، وهي جهد الإمداد والتيار المحرك، لتقدير ظروف التشغيل وتوفير الحماية.

يتم إرسال المعلمات المقاسة إلى المستخدم عبر وحدة GSM SIM800L لأغراض المراقبة والتحكم عن بُعد. تم تطوير تطبيق Android، Blynk، لتوفير واجهة مستخدم أفضل، وتشغيل قائم على الوقت، وحالة المضخة وإشعارات الاستجابة، وما إلى ذلك. يتم توفير حماية للمضخة (محرك تحريضي ثلاثي الأطوار) من خلال متحكم دقيق ESP32. يتم برمجة خصائص الترحيل المناسبة في المتحكم الدقيق للحماية من أنواع مختلفة من الأعطال مثل التحميل الحراري الزائد، التشغيل بمرحلة واحدة، انخفاض/زيادة الجهد، اختلال التوازن في الجهد، والدوران العكسي. تم اختبار النظام في المختبر ولوحظ أن جميع وسائل الحماية تعمل بشكل مرضي.

Acknowledgement

We thank Allah the Almighty for giving us the will and patience to carry out this modest work. We would like to express our warm thanks to our mentor, **Dr. Hakima Cherif**, for her support, guidance, and advice, which were very precious to us.

We cannot forget to also thank Mr. President and the gentlemen of the jury, as well as all the staff of the Faculty of Technology at Echahid Hamma Lakhdar University of El-Oued.

Furthermore, we extend our sincere thanks and gratitude to **Dr Sassi Zohier**, **Mr Alchraf Khalil**, **Dr. Chouaib Labiod**, and **Dr Nabil Aouragh** for their support and assistance throughout the project. We are also grateful to all the teachers who have shared their knowledge with us from the early stages of our education until this moment.

In particular, we would like to thank the professors of our college for their dedication, support, and encouragement. We also extend our gratitude to those who have provided us with assistance, whether they are close or distant.

List of figures

Fig I.1: Irrigation by planks.....	6
Fig I.2: Irrigation by the stingray.....	7
Fig I.3: Irrigation by basins	7
Figure I.4: Sprinkler irrigation	8
Fig I.5: Micro irrigation (drip)	9
Fig I.6 Presentation of the irrigated areas by central irrigation pivot.....	9
FigI.7:Submersible pumps	11
Fig I.8:Submersible pumps	11
Fig I.9:thermal magnetic circuit breaker(MCB)	12
Figure I.10:phase-sequence relay	13
Fig II.1: Temperatures of the rotor and the stator according to the two-time-constant model when the motor is running in constant cyclic overload. Pre-warning level is set to 90%.....	22
Fig II.2: Single phasing effect	22
Fig II.3: Phasor graph in a) reflects perfect symmetry in 3 phase power system. All vectors corresponding to 3 phases have the same magnitude and there is 120° between two adjacent vectors. Phasor graph in b) reflects asymmetry in power system. The vectors have different length and the angular shifts are different than 120° between adjacent phases.....	23
Fig II.4: it shows voltage unbalance condition	25
Fig II.5: Induction motor power flow operating under unbalanced conditions considering the positive and negative sequence power.....	25
Fig II.6: Water pumping system in agricultural field	28
Fig II.7: Basic Configuration of the Cloud-Based Monitoring System.....	30
Fig II.8: Internet of things.....	30
Fig III.1 proposed system	38
Fig III.2 Organizational chart of proposed system.....	39
Fig III.3 LV 25 and LA25 sensors	40
Fig III.4 schematic of sensor	41
Fig III.6 circuit PCB of the sensor.....	42
Fig III.7 board of sensor	43

List of figures

Fig III.8 TTGO T-Call esp32 sim800l card	44
Fig III.9 Circuit diagram of esp32.....	45
Fig III.10 Log in to BLYNK app	47
Fig III.11 Create a New Project.....	47
Fig III.12 Getting Auth Token.....	48
Fig III.13 Widget box.....	49
Fig III.14 choose the card type.....	50
Fig III.15 receive the token	51
Fig III.16 add to display the value of current and voltage.....	52
Fig III.17 LED light to display the phase status.....	52
Fig III.18 notification settings	53
Fig III.19 SuperChart settings	53
Fig III.20 the control buttons.....	54
Fig III.21 Application interface	55
Fig III.22 The system in healthy state.....	56
Fig III.23 & 24 The system in overvoltage state.....	56
Fig III.25 & 26 The system in undervoltage state.....	57

List of tables

Tab I.1: Types of Contactors.....	13
Tab I.2: Types of Phase-Sequence Relays.....	14
Tab I.3: Overload Relay Types.....	15
Tab II.1: Faults, their impacts, and causes.....	26

List of contents

General Introduction1

Chapter I

Overview on irrigation systems

I.1 Introduction4

I.2 Definition of irrigation4

I.3 Interest of irrigation4

I.4 Agricultural irrigation techniques4

 I.4.1 Surface irrigation systems (gravity) : 5

 I.4.1.1 Irrigation by planks : 5

 I.4.1.2 Stingray irrigation 5

 I.4.1.3 Irrigation by basins..... 6

 I.4.2 Sprinkler irrigation..... 6

 I.4.3 Micro irrigation (drip) : 7

 I.4.4 Pivot irrigation: 8

I.5 Comparison of irrigation methods.....9

I.6 Components of Irrigation Systems9

 I.6.1 The pump 9

 I.6.2 Induction Motors 10

 I.6.3 Electrical Components for Controlling and Monitoring 11

I.7 Conclusion.....16

I.8 Reference17

Chapter II

The faults in the water pump and the intelligent monitoring system

II.1 Introduction.....21

II.2 Common Faults in Water Pumps21

 II.2.1 The faults of induction motor 21

 II.2.1.1 Thermal overload 21

 II.2.1.2 Single Phasing 22

 II.2.1.3 Phase Asymmetry 23

 II.2.1.4 Overvoltage 24

List of contents

II.2.1.5 Undervoltage	24
II.2.1.6 Voltage Unbalance.....	25
II.2.2 The faults of water pumps.....	26
II.2.2.1 Low Water Pressure	27
II.2.2.2 Noisy Operation	27
II.2.2.3 Maintenance Tips to Prevent Water Pump Problems.....	27
II.3 Intelligent Monitoring Systems	28
II.3.1 Supervisory Control and Data Acquisition (SCADA) system	29
II.3.2 Monitoring Conditions of the On- Premises SCADA System	29
II.3.3 IoT technology	30
II.3.3.1 Network Layer	31
II.3.3.2 Application Layer.....	32
II.3.4 Benefits of Intelligent Monitoring	32
II.4 Conclusion.....	32
II.5 References	33

Chapter III

Implementation of an Intelligence Monitoring system a Water Pump using ESP32

III .1 Introduction.....	37
III.2 The monitoring system proposed of water pump.....	37
III.2.1 Advantages of IOT based agriculture motor control	39
III.3 Stages of carrying out our project.....	39
III.3.1 First part: design and construction of the entire electronic system.....	39
III.3.2 Second part: the mobile application (Blynk)	45
III.4 Practical test	49
III.5 The Test results and discussion.....	50
III.6 Conclusion	57
III.7 References	58
General conclusion.....	59

General

Introduction

General Introduction

Motivation

Efficient irrigation is crucial for sustainable agriculture, as it directly impacts crop yield and water resource management. The reliability of irrigation systems, particularly water pumps, is essential to ensure consistent and adequate water supply. Faults in water pumps can cause significant disruptions, leading to water wastage and increased maintenance costs. The integration of intelligent monitoring systems using modern technologies such as IoT, ESP32, and GSM modules like SIM800L provides a promising solution to enhance the efficiency and reliability of irrigation systems. This approach can lead to proactive maintenance and optimal water usage, thus supporting sustainable agricultural practices.

Problems Addressed

- ✓ Comprehensive Understanding of Irrigation Systems: The need to understand the different types of irrigation systems, their components, and how they function.
- ✓ Identification and Management of Pump Faults: Addressing the common faults in water pumps and their impact on irrigation system performance.
- ✓ Implementation of Intelligent Monitoring Systems: Developing and implementing a cost-effective, reliable monitoring system using IoT, ESP32, and SIM800L GSM modules to detect and manage faults in real-time.

Chapter Structure

Chapter 1: Overview of Irrigation Systems

This chapter provides a comprehensive overview of irrigation systems, starting with their definition. It explores various types of irrigation systems, including surface irrigation, sprinkler irrigation, drip irrigation, and subsurface irrigation. The chapter also delves into the key components of these systems, particularly focusing on pump water systems and electrical control components essential for efficient operation.

Chapter 2: The Faults in Water Pumps and Intelligent Monitoring

This chapter examines the common faults in water pumps and their impact on irrigation system efficiency. It explores mechanical, electrical, and hydraulic faults,

General Introduction

discussing their causes, consequences, and how they can disrupt irrigation processes. The chapter introduces the concept of intelligent monitoring systems, which utilize advanced sensors and data acquisition technologies to continuously monitor pump performance and detect faults early.

Chapter 3: Implementation of Intelligent Monitoring System in Water Pumps Using ESP32

This chapter provides a practical guide to implementing an intelligent monitoring system for water pumps using the ESP32 microcontroller and the SIM800L GSM module. It covers the technical aspects of system setup, sensor integration, data acquisition, and real-time monitoring, leveraging the capabilities of IoT to enhance pump reliability and efficiency.

By providing a thorough understanding of irrigation systems, identifying potential faults in water pumps, and offering a practical approach to implementing an intelligent monitoring system, this work aims to enhance the efficiency and reliability of agricultural water management. This comprehensive approach supports sustainable agricultural practices and optimal resource utilization.

Chapter I

Overview on irrigation systems

I.1 Introduction

Irrigation is a critical practice in agriculture, enabling the provision of water to crops in a controlled manner to ensure their optimal growth and yield. This chapter provides a comprehensive overview of irrigation systems, focusing on their definition, types, key components—particularly pump water systems and electrical components for controlling and monitoring—and the impact of motor faults on these systems. By understanding these elements, we can better appreciate the complexities and importance of efficient irrigation in modern agriculture.

I.2 Definition of irrigation

Irrigation is the process of artificially supplying water to cultivated plants to increase production and allow their natural development, in cases of water shortages caused by lack of rain, excessive drainage, or a decrease in groundwater, particularly in arid areas. However, irrigation improves agricultural land yields but involves the use of large quantities of water. The area of irrigated land has significantly increased to meet the growing population and food needs. With 70% of global water consumption, agriculture is undoubtedly the most water-consuming sector [1,2]. Among the types of irrigation techniques, we can notably mention: surface irrigation, sprinkler irrigation, and drip irrigation[3].

I.3 Interest of irrigation

Irrigation is an effective management tool against the hazards of rainfall and it is crucial for the world's food resources. The use of irrigation has many advantages. It allows to increase the area of cultivated areas, especially in arid areas, It makes it possible to choose high-yielding varieties by applying the necessary fertilizers and thus makes these economically interesting cultures. It has the effect of promoting the increase of yields, and in a general way to intensify and stabilize production by freeing ourselves from the climatic variations.

I.4 Agricultural irrigation techniques

Agricultural irrigation techniques are methods of bringing water to crops to increase their production, and allow their normal development in the event of a water deficit induced by rainfall deficit and are classified in surface irrigation, sprinkler irrigation and micro irrigation. Decide whether to select an irrigation technique or switch to a more efficient is complicated. From a water conservation point of view, the choice is simple, the water savings increase when switching from surface irrigation to sprinkling and

Chapter I: Overview on irrigation systems

sprinkling with micro irrigation. However, the success of an irrigation technique will be very depending on the site, situational factors as well as the level of management used. The technique of existing irrigation must be evaluated very precisely before switching to another technique.[4] Depending on the way in which the water is brought to the field and how it is distributed, three main modes watering are usually practiced.

I.4.1 Surface irrigation systems (gravity) :

Surface irrigation systems are classified in ascending order of their efficiency in :

I.4.1.1 Irrigation by planks :

Plank irrigation consists of running a thin layer of water on a soil inclined by 0.2 to 3%. The flow rate to be poured depends on the slope, the width and the length of the board. This method is by far the most difficult because it is necessary to adjust the irrigation flow of each board with all the other variables. One of the practical formulas is that of Puncture which consists of determine the length of the board which depends on the infiltration of the soil, which would correspond to the runoff time. In other words, the aiguede opens the valve and waits for the water to arrive at the bottom of the board, and at that moment he closes the inlet valve[5].



Fig I.1: Irrigation by planks

I.4.1.2 Stingray irrigation

The irrigation with the line or by channel is perfectly suitable for the soil having a slope between 0.2 and 3%. The furrows are separated by a variant distance between 0.6 and 1.25 m, depending on the type of soil and culture. Depending on the flow available, one or more furrows can be irrigated at a time. Stingrays can be parallel or perpendicular to the permanent water supply channel. Generally speaking, irrigation is carried out according to a single flow rate or according to a succession of two different flow rates, a first large flow rate which is called the attack flow rate and a second lower flow rate which is called

Chapter I: Overview on irrigation systems

maintenance flow. Stingray irrigation lends itself better to mechanization by siphon, by vannette ramp, by flexible sheath or by Trans irrigation [5].



Fig I.2: Irrigation by the stingray

I.4.1.3 Irrigation by basins

Basin irrigation is best known in gravity irrigation. Her practice on a leveled floor (slope 0.1 to 1%) as well as the simplicity of the operation, which consists in filling the basin, mean that this technique is frequently used, the size of the basins is from 40 to 50 m² and this technique is known under the name "Robât". The latter causes a significant loss of area, due to the large number of partitions [5].



Fig I.3: Irrigation by basins

I.4.2 Sprinkler irrigation

Spray irrigation is recommended in the following cases :

- Shallow soils, which cannot be properly leveled for an irrigation of surface, while maintaining a sufficient depth.
- Too permeable soils, which do not allow an even distribution of water in the framework of an irrigation with surface runoff.

Chapter I: Overview on irrigation systems

- Irregularly sloping terrain with uneven microrelief, not allowing the establishment of a gravity service with a free surface.

On the other hand, it should be avoided in very regularly windy regions (winds above 4 or 5 m / s considerably degrade the homogeneity of the watering) and also when the irrigation is made with salt water on plants with foliage sensitive to salt.

A pressurized irrigation installation is usually composed of equipment providing the pressure necessary for its operation, measuring and control devices of flow, and a main pipe bringing the water to the secondary and tertiary pipes.

Other elements can be used, in particular a filter or a battery of filters and a device for adding fertilizing elements.

The consideration of the following factors is necessary for the conduct of a project of sizing of any pressurized irrigation system :

- Determine the size and shape of the surface to be irrigated, its topography and the type of soil.
- B. The available or potential sources of water and their characteristics.
- C. The climatic conditions in the region, the accessibility to the plot and the cultivation at irrigate. [5]



Figure I.4: Sprinkler irrigation

I.4.3 Micro irrigation (drip) :

In drip irrigation, the water is delivered to the plant at a low dose thus resulting in the moistening of a fraction of the soil. This makes it possible to limit the losses by evaporation and percolation. It also reduces the development of weeds. It puts also implement fixed and light equipment. In most cases, it requires a automation through controllers associated with volumetric and/or hydraulic valves and solenoid valves[5].



Fig I.5: Micro irrigation (drip)

I.4.4 Pivot irrigation:

Axial irrigation was invented in the United States in the late forties, began in France in the sixties [6-7]. The concept of this type of irrigation is based on the idea of natural irrigation by rain [8]. Where it represents the waterfall of the sprinklers in the form of rainfall on the soil at a rate that creates sufficient moisture content in the root zone with the least amount of deep infiltration. In general, the sprinkler irrigation mechanism is done by pumping water along a network of pipes to fixed or rotating sprinklers that are attached to the exit points. The pressure forces the water to penetrate into the nozzle head and is distributed as of droplets falling on the ground [9, 10].



Fig I.6 Presentation of the irrigated areas by central irrigation pivot.

The central pivot system consists of a long pipeline connected to a fixed or pivot point and the pipeline moves around the pivot point in a circle, the pipeline being transported on a wheeled tower. The power source for moving the wheels is electric or hydraulic. This means that the pivot point represents the center of the circle, while the pipeline represents a radius of the circle during the movement [11].

The main advantages of center pivot irrigation machines [7]:

- ✓ The distribution of water is simplified thanks to the use of a fixed focal point.
- ✓ The direction and alignment are controlled relative to a fixed focal point.
- ✓ The relatively high uniformity in the application of water can be easily achieved by moving the nozzles continuously.
- ✓ Once the irrigation is complete, the system is at the starting point for the next irrigation.
- ✓ Ensure proper irrigation management because it is easy to apply precise and timely water timely

I.5 Comparison of irrigation methods

The transition from surface irrigation to sprinkling is one of the most widespread conversions to save water.

The reasons for this conversion lie in the fact that surface irrigation techniques are inherently less efficient and require more work than sprinkler irrigation. However, before making this conversion, various factors must be taken into account: the effects on yields, water, labor, energy savings, the economic aspect, the climatic conditions and the characteristics of the field. To choose an irrigation method, the farmer must know the advantages and the disadvantages of different methods. Unfortunately in many cases, there is no a good solution because all methods have their advantages and disadvantages [5].

I.6 Components of Irrigation Systems

An efficient irrigation system comprises several key components, each playing a crucial role in water delivery and management. This section focuses on the pump water systems and electrical components essential for controlling and monitoring irrigation.

I.6.1 The pump

Pump is a machine that is used to move liquid water or oil through the piping system and to increase the pressure of the liquid. A further definition of a pump is a machine that uses energy transformations to increase the pressure of a liquid. The energy input into the pump is usually the energy source used to power the drive. Most commonly, electric motors are most often used as propulsion by using electric power[12].

Its function is to lift groundwater to the surface and provide sufficient water pressure for irrigating the entire desired area. There are two types:

✓ Submersible pumps

They have strong water leakage protection and are submerged in groundwater at depths of 30 to 60 meters with a power of 5.5 or 7 horsepower.



Fig1.7:Submersible pumps

✓ Surface pumps

They consist of an electric motor connected to a centrifugal pump placed on the surface or in a well at depths less than 15 meters. Mostly, pumps with a power of 5.5 or 7 horsepower are used.



Fig I.8:Submersible pumps

I.6.2 Induction Motors

Induction Motors is the beating heart of this system because Almost 70% of the machines used in industries now a days are 3 phase induction motors. As the ac power is used in generation, transmission and distribution induction motors occupied significant place in industrial drive applications and out rule the dc motors which were earlier used for industrial applications. Induction motors are of two types based on the construction: Squirrel cage induction motor and slip ring induction motors. Squirrel cage induction motors are widely used in motor and drive applications.

Chapter I: Overview on irrigation systems

An induction motor comprises a magnetic circuit interlinking two electric circuits which are placed on the two main parts of the machine: (i) the stationary part called the stator and (ii) the rotating part called the rotor. Power is transferred from one[13].

❖ Benefits Induction Motors

Induction motors are simple and rugged in construction. Advantage of induction motors are that they are robust and can operate in any environmental condition.

Induction motors are cheaper in cost due to the absence of brushes, commutators, and slip rings.

- **Induction Motors 5 HP:** Full load current this motor 7.3A
- **Induction Motors 7.5 HP:** Full load current this motor 11.7A
- **Induction Motors 10 HP:** Full load current this motor 13.4A

For the motor to work with the pump, it requires the electrical control cabinet

I.6.3 Electrical Components for Controlling and Monitoring

Modern irrigation systems utilize advanced electrical components to enhance efficiency and precision in water application.

❖ Thermal magnetic circuit breaker(MCB)

An MCB is a type of electrical switch designed to automatically turn off the electrical circuit during abnormal conditions such as overload and short circuits within domestic or commercial installations. It provides protection for smaller loads and is typically used in low current circuits[14].



Fig I.9:thermal magnetic circuit breaker(MCB)



❖ Contactor

A contactor is an electromagnetic switch used to control high-power circuits. It is used to connect or disconnect the circuit. The electrically controlled contactor uses a power supply level that is much lower than that of the switching circuit. It is usually used to control equipment such as motors, and is used with large power supplies. Unlike some

Chapter I: Overview on irrigation systems

ordinary push button switches, contactors use electronic means to switch power circuits, which is more convenient and safer[16].

Table I.1: Types of Contactors

Types of Contactors	Photos of the Components
Electromagnetic Contactors	
Thermal Contactors	
Solid-State Contactors	

❖ Phase-sequence relay

A phase sequence relay is a protective relay. It guards a 3-phase device against any potential damage due to sequence change. They are deployed anywhere with a phase-sequence change that can damage the device or circuit. They work like a conventional electric relay. Once a phase fails or if a sequence changes, the phase sequence relay cuts off the working. The high-end models pack more complex circuitry that can control the connected device as required. Also, it can even change the sequence of the relay automatically if any phase sequence shift is introduced[17].





Figure I.10: phase-sequence relay

Chapter I: Overview on irrigation systems

The phase-sequence relay operates based on the order of the incoming voltage phases (A, B, and C) in a three-phase system. It detects the correct phase rotation (A-B-C or R-S-T) and ensures that the connected equipment operates within the designated phase sequence. If the phase sequence is incorrect or reversed, the relay identifies the anomaly and sends a signal to disconnect the supply or trigger an alarm, preventing potential damage to the connected equipment[18].

Phase-sequence relays use different technologies to determine the phase order, such as electromagnetic, static, or microprocessor-based relays. Electromagnetic relays employ a rotating magnetic field, while static relays use electronic components like diodes, transistors, and operational amplifiers. Microprocessor-based relays are the most advanced, utilizing digital signal processing techniques for accurate and reliable phase sequence detection[18].

Table I.2:Types of Phase-Sequence Relays

Types of Phase-Sequence Relays	Photos of the Components
Electromechanical Relays	
Static Relays	
Microprocessor-based Relays	







❖ Overload Protection relay

The main purpose of relays is for overload protection of electric motors Phase-off protection and asymmetric protection. An electric motor converts electrical energy into a device of mechanical energy, used as the power to drag various production machinery, is

Chapter I: Overview on irrigation systems

The importance of industry, agriculture, national defense construction and the normal progress of people's lives Guarantee [15].

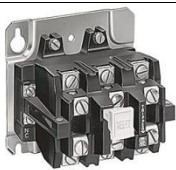
Table I.3:Overload Relay Types

Overload Relay Types	Photos of the Components
Thermal Overload Relay	
Magnetic Overload Relay	
Bimetallic Thermal Overload Relay	
electronic overload relays	
Eutectic Overload Relay	
Fridge Overload Relay	

❖ Sensors

Sensors are the foundation of intelligent monitoring systems, collecting data on various parameters such as current, voltage, temperature, vibration, pressure, and flow rate. Common types of sensors used include:

- **Current and voltage Sensors:** Monitor electrical parameters to detect issues such as overloads or voltage imbalances.
- **Temperature Sensors:** Monitor the temperature of the motor and bearings to detect overheating.
- **Vibration Sensors:** Measure vibrations to identify mechanical issues such as imbalance or misalignment.
- **Pressure Sensors:** Track water pressure to detect anomalies that may indicate cavitation or leaks.
- **Flow Sensors:** Measure the flow rate to ensure the pump operates within its specified range[19,20].

❖ Data Acquisition Systems

Data acquisition systems collect and transmit data from sensors to a central monitoring unit. These systems ensure that data is accurately recorded and available for analysis[21].

❖ Control Units

Control units process the data received from sensors, applying algorithms to detect patterns and identify potential faults. They can trigger alarms or shut down the pump automatically to prevent damage[19,20].

❖ Communication Networks

Communication networks enable the transmission of data between sensors, control units, and monitoring platforms. Wireless networks and the Internet of Things (IoT) have enhanced the connectivity and accessibility of monitoring systems[19,21].

These components work together to create an integrated and intelligent monitoring system for water pumps, enabling real-time data collection, analysis, and response to ensure optimal performance and longevity of the equipment.

I.7 Conclusion

This chapter provides an overview of irrigation systems, highlighting their definition, types, and key components—especially pump water systems and electrical components for controlling and monitoring. Understanding these aspects is essential for designing and maintaining efficient irrigation systems that support sustainable agriculture and water management. In the next chapter, we will delve deeper into the effects of pump water faults on irrigation systems and intelligent monitoring techniques.

I.8 Reference

- [1] Kessira, M. "Conception d'un projet d'irrigation." Direction Du Développement Agricole Dans Les Zones Arides Et Semi-arides, Algérie, ouvrage (2013)
- [2] M. Said- and H. Salem, "Contribution à la vulgarisation des systèmes photovoltaïques utiliserpour l'irrigation par pivots traditionnels dans la région d'EL OUED," 2018.
- [3] S. Mus, B. Ali, S. M. Tawfiq, and A. H. Rashid, *Guide d' irrigation*. Maroc: Éducation, Recherche et Développement, 2004
- [4]<https://irrigazette.com/fr/articles/les-techniques-dirrigation-agricole>
- [5]Prof. Mohammed AZOUGGAGH « les différents systèmes d'irrigation »
- [6] Groupe mixte Pilotage de l'irrigation, *Le pivot*. Cemagref : Diff.Tec& doc, 1997.
- [7] Y. SOUALAH MOHAMMED and A. KOUKA "Etude hydraulique du système de pivot d'irrigation Type ANABIB," Mémoire de master, Département de génie mécanique, university of Eloued 2018.
- [8] Kincaid, Dennis C. "Application rates from center pivot irrigation with current sprinkler types." *Applied engineering in agriculture* 21.4 (2005): 605-610.
- [9] Martín-Benito, José MaríaTarjuelo, Manuel Valiente Gómez, and Juan LozoyaPardo. "Working conditions of sprinkler to optimize application of water." *Journal of Irrigation and Drainage Engineering* 118.6 (1992): 895-913.
- [10] Scherer, Tom. "Selecting a sprinkler irrigation system." (2005).
- [11] G. H. Mahmood, "Interactions of soil water run-off with overhead (centre-pivot) irrigation and soil cultivations," Harper Adams University, 2018
- [12] Hardee, RT and Sines, JL, *Piping System Fundamentals*, 2nd Edition, Engineered Software, Lacey, WA, 2009
- [13] Karmakar, Subrata, et al. *Induction motor and faults*. Springer Singapore, 2016.
- [14]Difference between MCB and MCCB in Electrical Systems, Author: ETEK Electric, Byetek-china, May 11, 2024
<https://www.etek-china.com/blog-news/difference-between-mcb-and-mccb-in-electrical-systems>
- [15] Orr M P. Thermal overload protection for electric motors on motor-operated valves[J]. *Federal Register*, 2012
- [16] Contactor Types, Advantages And Applications , By thorele, May 16, 2024
<https://thorele.com/contactor-types-advantages-and-applications>

Chapter I: Overview on irrigation systems

[17]What Is A Phase Sequence Relay? | How Does It Work, By zxz_100@163.com,
October 29, 2021

<https://caltsensor.com/what-is-a-phase-sequence-relay-how-does-it-work/>

[18]Phase-Sequence Relay, by WEBSITE electricity-magnetism

<https://www.electricity-magnetism.org/phase-sequence-relay/>

[19] Singh, Yurav, and Tom Walingo. "Smart Water Quality Monitoring with IoT Wireless Sensor Networks." *Sensors* 24.9 (2024): 2871.

[20] Zulkifli, Che Zalina, et al. "IoT-based water monitoring systems: a systematic review." *Water* 14.22 (2022): 3621.

[21] Stamatescu, Grigore, Anatoliy Sachenko, and Dan Popescu. "Convergence of Intelligent Data Acquisition and Advanced Computing Systems." *Sensors* 21.7 (2021): 226

Chapter II

**The faults in the water
pump and the intelligent
monitoring system**

II.1 Introduction

Water pumps are integral to the operation of irrigation systems, playing a critical role in transporting water from the source to the fields. However, the efficiency and reliability of these pumps can be compromised by various faults, which can disrupt irrigation schedules, reduce crop yields, and increase operational costs. This chapter explores the common faults that occur in water pumps and the importance of addressing these issues promptly. Additionally, it delves into the advancements in intelligent monitoring systems that help detect, diagnose, and prevent pump faults, ensuring the smooth operation of irrigation systems.

II.2 Common Faults in Water Pumps

Water pumps can experience a range of faults, each with potential implications for the efficiency and effectiveness of irrigation systems. Understanding these faults is the first step in mitigating their impact.

II.2.1 The faults of induction motor

The Induction motor is the heart of any pump, the protection of the induction motor against various types of faults is a highly important issue especially in case of poor quality of power supply. In this chapter we're going to mention a few types of fault in induction motor

II.2.1.1 Thermal overload

The thermal behavior of the stator and the rotor during startups and during constant overload situations differs significantly from each other. Due to this fact, the dynamics of the motor heating and cooling is typically modeled separately for the stator and for the rotor. Implementing the thermal overload protection in this way, it can be set to follow the thermal state of the motor optimally, and good and accurate protection against both short and long-time overload conditions can be accomplished, which allows the full use of the available capacity.

These curves have been simulated using the two-time-constant model for the stator and for the rotor. In this case, the pre-warning level is exceeded and the operator is notified. As a result, the tripping is prevented as the loading of the motor becomes suitably reduced. It can also be concluded from Figure 2.1 that a comprehensive overload protection in fact requires the use of the two-time-constant model for the rotor and for the stator, and in this way, the full utilization of the available capacity of the motor is ensured. However, adequate protection can also be implemented using the single-time-constant model, which is set to allow the normal use of the motor drive with a suitable margin [1].

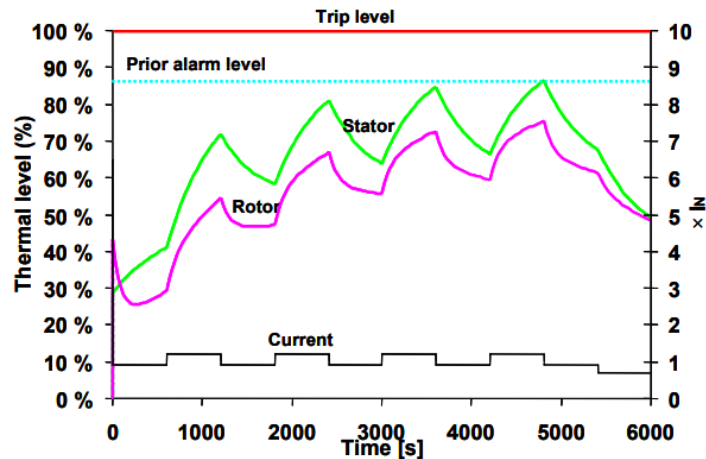

Fig II.1: Temperatures of the rotor and the stator according to the two-time-constant model when the motor is running in constant cyclic overload. Pre-warning level is set to 90%.

II.2.1.2 Single Phasing

In an extreme case of uneven running, single phasing may be considered. It is not a serious issue; however, it should be considered if one phase of a three-phase source fails during a failure situation or if a 3PIM is intentionally connected to a single-phase source. This is known as "single phasing." When a three-phase motor works in the single-phase condition, it might strive to generate the maximum horsepower necessary to meet the demand. The motor will continue to try to run the load until it is damaged or the protecting components relocate the motor out of the line. Single phasing increases phase currents causing overheating, which destroys the motor [2]. A downline on the distribution grid or a burst pole upper fuse might cause a phase loss on a three-phase line. A single-phase overload scenario that permits one fuse to rupture or device breakdown inside the end customer's plant might cause a single-phase loss.

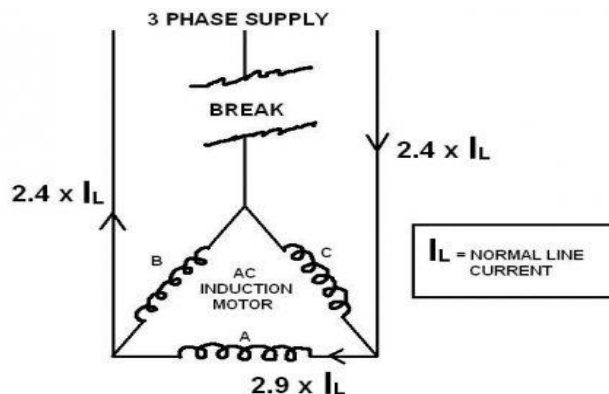

Fig II.2: Single phasing effect

In single phasing protection for 3 phase induction motor system, if any one of the phases is faulted then automatically trips both the contactors. Generally in single phase supply

voltage is lower value than specified value. On this value of voltage motor is unable to start. Comparator which compares single phasing supply voltage and rated specified voltage, and single sends to microcontroller and microcontroller generates single and contactor will be trip through relay drive which stop the motor if motor is running and does not allow to motor start in case of standstill.

II.2.1.3 Phase Asymmetry

The most commonly used electrical machines in industry today are the squirrel cage induction machines. This is mainly due to their reliability, robustness, and that they are inexpensive to manufacture. Squirrel cage machines with high power ratings are prefabricated and are manufactured with copper rotor bars and end-rings, while machines of lower power ratings are manufactured by using die-casting techniques. Manufacturing die-cast rotors can raise several problems, due to the fact that rotors must be free from asymmetries. An asymmetry in the rotor cage will cause asymmetrical distribution of the rotor currents, and due to this, mechanical and thermal stresses on the cage can damage a rotor bar. Damage of one rotor bar can lead to the damage of surrounding bars, thus the damage can spread, leading to multiple bar fractures. In the case of a crack, the bar will overheat and cause the bar to break. The surrounding bars will carry higher currents and will also be subjected to larger thermal and mechanical stresses, thus being made more susceptible to cracking. Most of the current which would have flown in the broken bar will flow in the two bars adjacent to it. The large thermal stresses may also damage the rotor laminations. The temperature distribution across the rotor lamination is also changed due to rotor asymmetry [3]. Cracks in bars can be present at various locations, along the slot and at the end-ring-to-bar joints.

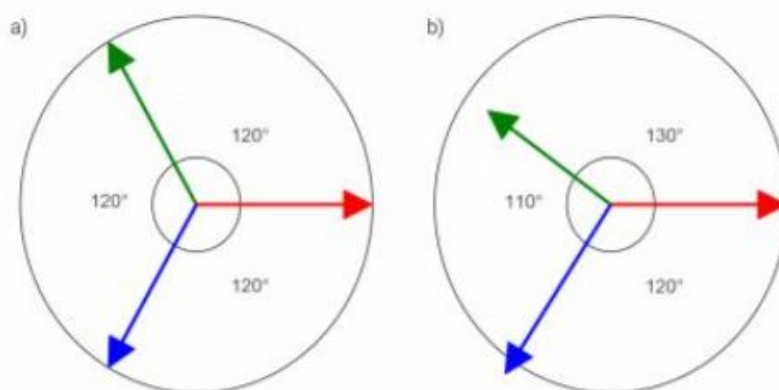
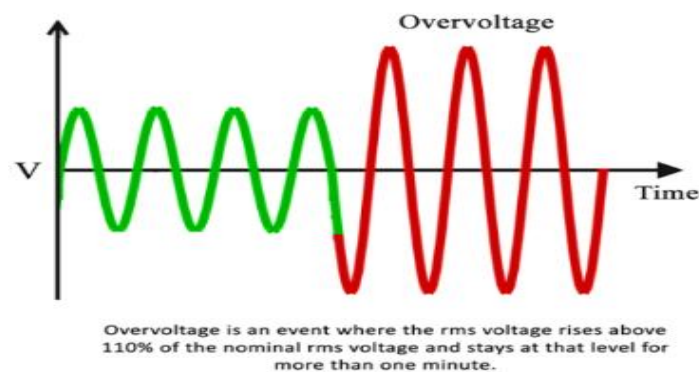

Fig II.3: Phasor graph in a) reflects perfect symmetry in 3 phase power system. All vectors corresponding to 3 phases have the same magnitude and there is 120° between two adjacent vectors. Phasor graph in b) reflects asymmetry in power system. The vectors have different length and the angular shifts are different than 120° between adjacent phases.

This is when the load on all three phases is not balanced correctly. If supply is more than 5% out of balance then this can cause damage to AC motors and pumps through thermal stress. Only Phase Failure Relays with Phase Asymmetry monitoring can detect this fault condition.

II.2.1.4 Overvoltage

An overvoltage is a situation which occurs when the system voltage rises over 110% of the nominal voltage ratings. Overvoltage is caused due to several reasons such as sudden reduction in loads, switching of transient loads, lightning strikes, failure of control equipment such as voltage regulators, neutral displacement. This situation of overvoltage causes damage to components connected to the supply which may further lead to heating, over flash, insulation failure and may destroy electronic components.[4]



Overvoltage it also has comparator which compare two voltage one from supply and another from the voltage drop across the variable resistance.

II.2.1.5 Undervoltage

Normally undervoltage occurs when the voltage supplying the drive is too low. The obvious cause that can be incurred is that the incoming supply is low or not the specified one. For example, a 460V drive powered by 220V will cause the situation called under voltage [4].

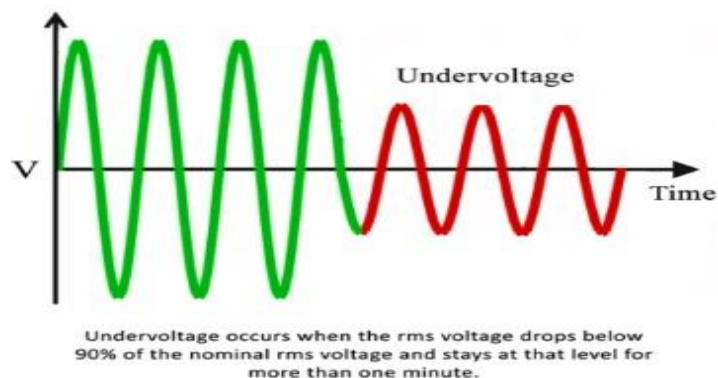

In under voltage protection of 3 phase induction motor protects the motor from the under voltage. When supply system has low voltage than the rated of induction motor then under voltage protection section of protection supply is provided to motor.

II.2.1.6 Voltage Unbalance

The operation of induction motor under voltage unbalance conditions produce two rotating fields in the motor air gap, one in the forward direction of the motor rotation (positive sequence) and another in the opposite direction (negative sequence), giving as result an elliptical field [5]. Consequently for a given load and percentage of voltage unbalance, the phase currents and temperature rise much greater than when operating under the same load conditions and balanced voltages, affecting the motor performance.

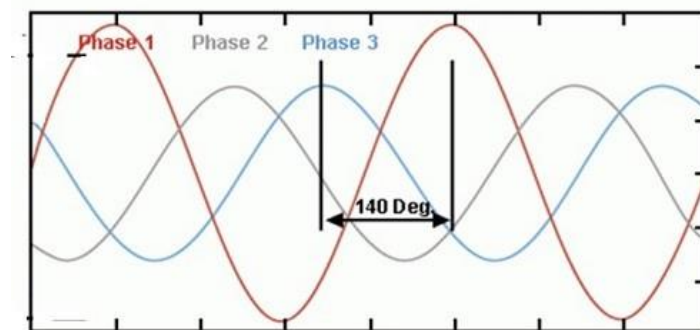

Fig II.4: it shows voltage unbalance condition

The effects of voltage unbalance on the motor such as, unbalanced currents, temperature rise, increased losses, output power and torque reduction, pulsation torques and speed reduction, has been studied by several authors, [6]-[7]. These studies are generally focused on the effects caused by the negative sequence component of voltage. Other authors have considered both the positive and negative sequence voltage [8]-[9], [10]-[11].

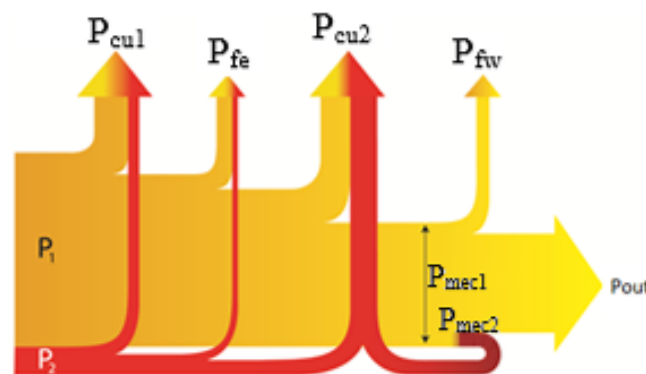

Fig II.5: Induction motor power flow operating under unbalanced conditions considering the positive and negative sequence power

Table II.1 depicts the general faults that occur in an induction motor along with their impacts and general causes.

Table II.1: Faults, their impacts, and causes

Fault	Impact	General causes
Thermal overload	Damage to stator and rotor windings. Life of insulation decreases [12-13].	Under voltage, voltage imbalance, overloading, etc
Single phasing	The current in remaining phases increases significantly thus Single leading to excessive heating and thermal overload. Slip increases, power factor becomes poor, maximum loading capacity decreases [14-15], [16].	The fuse of one phase melts.
3 phase and blocked rotor	Stator and rotor windings may be damaged permanently [13], [17].	Mechanical bearings failure.
Over voltage	It may result in excessive high flux that can create saturation and thermal damage of the steel core [18], [12].	Low loading on the distribution system.
Under voltage	Motor draws higher current which leads to overloading. Slip increases, ohmic losses increase, efficiency goes down, and life of motor reduces [18-19].	High loading on the distribution system.
Voltage Unbalance	Large negative sequence components are introduced. Excessive overheating of the motor, derating of motor [10], [20].	Open delta connection, unbalanced loading, and impedances

II.2.2 The faults of water pumps

Water pumps play a vital role in various applications, from residential water supply to industrial processes. However, like any mechanical system, they are susceptible to problems and malfunctions. In this chapter, we will explore some of the most common water pump problems and provide effective solutions to keep your water pumping smoothly.

II.2.2.1 Low Water Pressure

Low water pressure can be frustrating and may indicate underlying issues with your water pump system. Common causes include:

- **Clogged or Damaged Impeller:** Over time, impellers can become clogged with debris or wear out, reducing water flow.
Solution: Clean or replace the impeller to restore proper water flow.
- **Airlock in the System:** Air bubbles trapped in the pump or pipes can disrupt water flow and reduce pressure.
Solution: Bleed air from the system by opening a valve at the highest point.
- **Leaks in the Suction Line:** Leaks in the suction line can allow air to enter the system, affecting water pressure.
Solution: Inspect and fix any suction line leaks to maintain optimal pressure.

II.2.2.2 Noisy Operation

Unusual noises from your water pump can be a sign of trouble. Common causes include:

- **Air in the Pump:** Air trapped in the pump can cause vibrations and noise.
Solution: Bleed air from the pump to eliminate noise.
- **Loose or Damaged Components:** Loose or damaged parts can rattle or vibrate, creating noise.
Solution: Tighten or replace loose components for a quieter operation.
- **Cavitation:** Cavitation occurs when the pump operates at low pressure, causing bubbles to form and collapse, generating noise.
Solution: Address cavitation issues by adjusting the pump's speed or impeller size.

II.2.2.3 Maintenance Tips to Prevent Water Pump Problems

To prevent common water pump problems and ensure the longevity of your system, follow these maintenance tips:

- **Regular Inspections:** Periodically inspect your water pump for signs of wear, damage, or leaks.
- **Lubrication and Cooling:** Properly lubricate moving parts and maintain adequate cooling to prevent overheating.
- **Monitoring Pressure and Temperature:** Install pressure and temperature gauges to monitor the pump's performance.
- **Keeping the Pump Clean:** Maintain a clean environment around the pump to prevent debris from entering.

- Properly Sizing the Pump: Ensure your pump is appropriately sized for the application to avoid overloading.

Water pump problems can be a hassle, but with proper maintenance and timely troubleshooting, you can keep your water pump running smoothly. By addressing issues such as low water pressure, noisy operation, pump failures, leaks, and reduced flow rates, you can extend the life of your water pump and ensure reliable water supply for your needs. Remember that regular maintenance is the key to avoiding common water pump problems and enjoying uninterrupted water flow [21].



Fig II.6: Water pumping system in agricultural field

II.3 Intelligent Monitoring Systems

Advancements in technology have led to the development of intelligent monitoring systems that can detect, diagnose, and prevent faults in water pumps. These systems enhance the reliability and efficiency of irrigation systems by providing real-time data and predictive analytics.

II.3.1 Supervisory Control and Data Acquisition (SCADA) system

Supervisory Control and Data Acquisition (SCADA) systems are one of the control systems type under the general term of Industrial Control System (ICS). Other notable members of the set are Distributed Control systems (DCS) and Programmable Logic Controllers (PLC). They are used in critical infrastructure and industrial sectors [22]. Local control of industrial processes is the main function of the DCS while the PLCs are designed to comfortably acquire sensors, actuators and set points information from the field. It serves both the SCADA Systems and the DCS.

SCADA Systems is, however, different from the DCS which is localized to the industrial sites as its control and monitoring functions covers wide geographical areas as it supervises devices located thousands of kilometers apart from one another and from the control center. The critical infrastructure where they are applied include electrical power networks, natural gas and oil pipelines, roads and rail transportation systems. SCADA's primary functions are data acquisition, data processing for use by the operator, and control of remote devices by operator [23].

In SCADA System, data acquisitions, transmission systems and Human Machine Interface (HMI) software are integrated to function as a centralized control and monitoring system for processing several inputs and outputs. The collected information from the field is transferred to the computer based control center, where with the aid of HMI it is either displayed textually or graphically.

II.3.2 Monitoring Conditions of the On- Premises SCADA System

An on-premises system refers to the facilities that the customer owns and controls, as opposed to the third-party cloud-computing system where computing resources are made available for consumption on an as needed basis. The on-premises system is equipped with a LAN for control. This system connects Programmable Logic Controllers (PLCs) widely distributed in waterworks facilities. It also connects with SCADA systems, and Visual Display Terminals (VDTs). The basic configuration is this connected state. This system is scalable from the basic configuration to flexibly reconfiguring the system to meet the various operating conditions for the customer when introducing the system. For example, a wireless telemetering unit TELEMOT can be connected to the LAN for control. In addition to local facilities, the system can monitor and control the facilities at a distant location. To enable the monitoring data access from outside the premises of the facilities, we put a web server in the premises to set up a Virtual Private Network (VPN) and this allows the access by a dedicated Visual Display Terminal (VDT). In doing so, you could see the monitoring data.

This system is made based on the policy that values stable remote monitoring, control performance, and quick response of the system. This system uses the dedicated communication network or private network for monitoring and control. Since this system is separated from a public network, it is possible to maintain security. While it excels in terms of safety, there are access restrictions such as monitoring locations and accessible display devices [24].

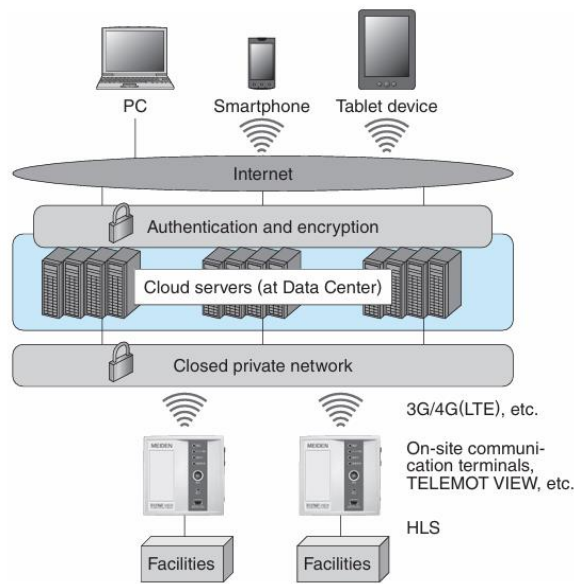

Fig II.7: Basic Configuration of the Cloud-Based Monitoring System

II.3.3 IoT technology

Intelligent monitoring is defined as a method which is used to monitor, control, manage and optimize the network by using different computational methods that will provide customers with relevant tools and information [25]. The internet of things (IoT) forms an important part of intelligent monitoring which connects people and devices using wireless sensor technology. It is a fast growing research area in the military, energy management, healthcare and many more. The concept of IoT was proposed by Kevin Ashton to demonstrate a set of interconnected devices [25]. IoT makes it possible to transfer information between different electronic devices embedded with new technology. The energy management is possible using energy harvesting mechanisms, which is a method of collecting energy from natural sources such as light, vibration, pressure etc. The combination of technologies such as Wireless sensor network (WSN), Radio frequency identification (RFID), Energy harvesting(EH) and Artificial Intelligence (AI) helps IoT to flourish widely.



Fig II.8: Internet of things

II.3.3.1 Network Layer

The network layer of IoT in WDS combines processing, managing and transmission of the data passed from the perception layer. This layer also helps in managing the network devices and communication technologies for transmission. The communication technology is classified into two based on the range of transmission. The cellular technology is used when long-distance transmission is required by using 2G, 3G, 4G [26]. The GSM, GPRS are some of the protocols used for long distance transmission. It requires more power consumption which makes them not much feasible for WDN. The short range protocols include Zigbee, 6lowpan, Radio frequency identification (RFID). The RFID uses an electronically programmed tag that is used to collect data [27]. The need of a programmed static tag makes it unreliable to use for measurement. The 6lowpan is an IP based protocol which can be easily connected to another IP network without any gateways. Another advantage is its low cost and power consumption. It supports both star and mesh topology. LoRa (Low Power Wide Area Network) is another protocol which gained public interest due to its low power consumption, cost and high data rate when applied in IoT and it uses the star topology. Zigbee is a widely used low power wireless protocol that provides low cost, security during communication. It also supports star, mesh and tree topology [28]. The advantages of 6lowpan, LoRa and Zigbee make the best choices to be used in WDS. Another technology that could be integrated with WDS is Artificial intelligence(AI). It is defined as a system that helps in problem-solving, decision-making, data identification, processing. Adaptive Neuro fuzzy inference system is one among the new AI method to predict the wastewater quality from industries [29] whereas an adaptive network based fuzzy system is used in [30] to detect the water quality from a paper mill. Artificial neural networks (ANN) and AI algorithms are also used in the water industry to monitor and predict the water quality which provides accurate results [31].

II.3.3.2 Application Layer

The application layer manages the applications that will be used in WDS. This layer also provides user's security and privacy. Cloud computing is one of the upcoming technology that could be used in the application layer of the WDS. Cloud computing is a solution for the storage, processing and management of heterogeneous data from different wireless devices and the cost of the service is based on the usage [32]. It can be considered as a separate layer between network and application layer. It helps IoT in storing backup data's, analysis and prediction of the received data based on each application.

II.3.4 Benefits of Intelligent Monitoring

- **Early Fault Detection:** Intelligent monitoring systems can detect early signs of faults, allowing for timely maintenance and repairs. This proactive approach minimizes downtime and prevents minor issues from escalating into major failures.
- **Enhanced Efficiency:** By continuously monitoring pump performance, these systems ensure that the pump operates at optimal efficiency. Adjustments can be made in real-time to address any deviations from standard performance.
- **Cost Savings:** Early detection and resolution of faults reduce the need for expensive emergency repairs and extend the lifespan of pump components. This leads to significant cost savings in maintenance and operational expenses.
- **Data-Driven Decision Making:** Intelligent monitoring systems provide valuable data that can be used to make informed decisions about pump operation, maintenance schedules, and system upgrades. This data-driven approach enhances overall system management.

II.4 Conclusion

Water pump faults can significantly impact the performance of irrigation systems, leading to reduced crop yields and increased operational costs. Understanding the common faults and implementing intelligent monitoring systems are crucial steps in ensuring the reliability and efficiency of these systems. Intelligent monitoring not only detects and diagnoses faults but also provides predictive analytics that help in proactive maintenance and efficient system management. In the next chapter, we will implement of an intelligence monitoring system a Water Pump using ESP32.

II.5 References

- [1] Hakola T. : "Moottorin suojaus", Sovellusohje, ABB Transmit Oy, 1992
- [2] De Oliveira, S. E. Operation of Three Phase Induction Motors Connected to One-Phase Supply. IEEE Transactions on Energy Conversion, 1990;5(4):713-718.
- [3] R. Escarela-Perez, S. V. Kulkarni, J. Alvarez-Ramirez and K. Kaushik, Analytical Description of the Load-Loss Asymmetry Phenomenon in Three-Phase Three-Limb Transformers, IEEE Transactions on Power Delivery, Vol. 24, No. 2, pp. 695-702, 2009.
- [4] Programmable Logic Controller And Industrial Automation Introduction By- Madhuchhanda Mitra and Samarjit Sen Gupta
- [5] G. J. Retter, "Matrix and Space-Phasor Theory of Electrical Machines", Académiai Kiadó, 1987, p. 411.
- [6] A. Siddique, G.S. Yadava and B. Singh, "Effect of voltage unbalance on induction motors", in Proceedings IEEE International Symposium on Electrical Insulation, 2004, pp. 26-29.
- [7] "NEMA Motors and Generators", Standard Publication ANSI/NEMA MG1-2003, Revision 1-2004, Publishing by NEMA, Rosslyn, USA, 2003.
- [8] V. Sousa, P. R. Viegó, J. R. Gómez, E. C. Quispe and M. Balbis, "Estimating induction motor efficiency under nocontrolled conditions in the presences of unbalanced and harmonics voltages," in Proceedings CHILEAN Conference on Electrical, Electronics Engineering, Information and Communication Technologies (CHILECON), 2015, pp. 567-572.
- [9] S. M. Ahmed, H. Abu-Rub, S. S. Refaat and A. Iqbal, "Diagnosis of stator turn-to-turn fault and stator voltage unbalance fault using ANFIS," International Journal of Electrical and Computer Engineering, vol. 3, No. 1, pp. 129-135, Feb. 2015.
- [10] A. M. S. Mendes, E. C. Quispe, X. M. López-Fernández, and A. J. Marques Cardoso, "Influence of the positive sequence voltage on the temperature of three-phase induction motors," in Proceedings XIX International Conference on Electrical Machines - ICEM 2010, 2010, pp. 1-6
- [11] M. Jannati, T. Sutikno, N. R. N. Idris and M. J. A. Aziz, "Modeling of balanced and unbalanced three-phase induction motor under balanced and unbalanced supply based on winding function method," International Journal of Electrical and Computer Engineering, vol. 5, No. 4, pp. 644-655, Aug. 2015.

- [12] S. Horowitz and A. Phadke, Power system relaying, 3rd ed. John Wiley & Sons, Ltd., United Kingdom, 2008, pp. 159-190.
- [13] P. Anderson, Power system protection. McGraw-Hill, New York, 1999, pp. 752-795.
- [14] W. H. Kersting, “Causes and effects of single-phasing induction motors”, IEEE Trans. Ind. Appl., vol. 41, no. 6, pp. 1499-1505, 2005.
- [15] M. Sudha and P. Anbalagan, “A novel protecting method for induction motor against faults due to voltage unbalance and single phasing”, Ind. Electron. Soc., 2007.
- [16] M. Nikpayam et al., “Vector control methods for star connected three-phase induction motor drives under the open-phase failure”, J. Oper. Autom. Power Eng., vol. 10, no. 2, pp. 155-164, 2022.
- [17] M. Abasi et al., “A comprehensive review of various fault location methods for transmission lines compensated by FACTS devices and series capacitors”, J. Oper. Autom. Power Eng., vol. 9, no. 3, pp. 213-225, 2021.
- [18] P. Pillay, P. Hofmann and M. Manyage, “Derating of induction motors operating with a combination of unbalanced voltages and over or undervoltages”, IEEE Trans. Energy Conv., vol. 17, no. 4, pp. 485-491, 2002.
- [19] J. Gomez et al., “Behavior of induction motor due to voltage sags and short interruptions”, IEEE Trans. Power Del., vol. 17, no. 2, pp. 434-440, 2002.
- [20] A. Siddique, G. Yadava and B. Singh, “A review of stator fault monitoring techniques of induction motors”, IEEE Trans. Energy Conv., vol. 20, no. 1, pp. 106-114, 2005.
- [21] article about Troubleshooting Common Water Pump Problems and Solutions by [Jeffery Mason](#), Sep 26, 2023
- [22] K. Stouffer, J. Falco, and K. Scarfone, “Guide to Industrial Control Systems (ICS) Security”, Gaithersburg, MD: National Institute of Standards and Technology, 2015, doi: 10.6028/NIST.SP.800-82r2.
- [23] D.J. Gaushell and H. T. Darlington, “Supervisory Control and Data Acquisition”, Proc. IEEE, vol. 75, no. 12, pp. 1645–1658, 1987
- [24] Ken’ichi Amemiya, “Development of Hybrid Type Supervisory Control And Data Acquisition (SCADA) System”,MEIDEN REVIEW Series No.176 2019 No.2
- [25] Z. Zude, L. Quan, A. Qingsong, & X. Cheng, “Intelligent monitoring and diagnosis for modern mechanical equipment based on the integration of embedded technology and FBGS technology”. pp 1499 1511. 12 Nov.2011
<https://doi.org/10.1016/j.measurement.2011.05.018>

- [26] S. A. Sarawi, M. Anbar, K. Alieyan, M. Alzubaidi, "Internet of Things(IoT) communication proocols: Review", Proc. IEEE International conf. on Information Technology, 23 Oct. 2017.
- [27] M. U. Farooq, M. Waseem, S. Mazhar, A. Khairi, T. Kamal, "A Review on Internet of Things (IoT)", International journal of Computer Applications, vol.113(1), March 2015.
- [28] S. A. Sarawi, M. Anbar, K. Alieyan, M. Alzubaidi, "Internet of Things(IoT) communication proocols: Review", Proc. IEEE International conf. on Information Technology, 23 Oct. 2017.
- [29] Z. Fu, J. Cheng, M. Yeng, J. Batists, "Prediction of industrial wastewater quality parameters based on wavelet de-noised ANFIS model", Proc of IEEE 2018 Annual computing and communication workshop and conference (CCWC '08), 27 Feb. 2018.
- [30] J. Wan, M. Huang, Y. Ma, W. Guo, Y. Wang, H. Zhang, W. Li, X. Sun, "Prediction of effluent quality of a paper mill wastewater treatment using an adaptive network-based fuzzy inference system", Applied Soft Computing, vol. 11, no. 3, pp. 3238-3246, 2011.
- [31] A. H. Zare, "Evaluation of multivariate linear regression and artificial neural networks in prediction of water quality parameters", Journal of Environmental Health Science & Engineering, vol. 12, no. 1, pp. 1-8, 2014.
- [32] S. K. Alshattnawi, "Smart Water Distribution Management System Architecture Based on Internet of Things and Cloud Computing", IEEE International conference on new trends in computing sciences, pp. 289 294, 11 Jan. 2018.

Chapter III

**Implementation of an
Intelligence Monitoring
system a Water Pump
using ESP32**

III.1 Introduction

The motivation for this project stems from the challenges faced by farmers in managing irrigation systems. Often, crop fields are located far from the farmer's residence, necessitating long and frequent journeys to these remote locations. Irrigation is a crucial component of agriculture, requiring daily attention to ensure crops receive adequate water. Consequently, regardless of the distance, farmers must travel to their fields every day to operate irrigation systems and supply water to their crops.

Daily travel to crop fields wastes time and money, is physically demanding, and is inefficient. To address these issues, in this chapter we propose an intelligent monitoring system for water pumps using the ESP32 microcontroller with SIM800L GSM/GPRS module. This IoT-based solution allows farmers to control and monitor irrigation systems remotely via their smartphones, eliminating the need for daily travel. This system saves time, reduces costs, and improves agricultural efficiency and effectiveness.

III.2 The monitoring system proposed of water pump

The basic architecture of the proposed system is shown in **Figure III.1**. This proposed system is divided into three major sections;

- Android application.
- GSM module .
- Protection of water pump i.e. 3- Φ induction motor.

The pump (3- Φ induction motor) is connected to the supply through a contactor to turn on or turn off. The trip coil of the contactor is controlled by relays and these relays are controlled by a signal given by the microcontroller. To protect the motor, current, and voltage sensors are used to monitor the operating conditions. The protection algorithm is programmed in the microcontroller (ESP32 board). The Android app enables the user to communicate with the pump at a remote location. Basic Start and Stop operation of pump along with options and machine rating are given in the App. According to the options selected by the user, a string will be generated and the same will be sent to the motor end by SMS. The SMS sent by App will be received by the GSM module at the motor end. The message will be extracted by the microcontroller and further actions will be initiated. If the pump is turned on successfully then the microcontroller will feedback this status to the app by generating SMS, which will be sent by GSM modem. The timer options selected by the user are implemented by the microcontroller and it will turn on and turn off the pump according to the timer settings. The currents and voltages are sensed by the sensors and the microcontroller reads

their values. If the power supply is available then the microcontroller will send SMS through the GSM modem to inform the user. Protection against various types of faults is provided by a protection algorithm in the microcontroller. In case of any fault in the induction motor or problems in the power supply, the microcontroller will trip the pump and communicate the message back to the user through a GSM modem. Hence, the user will remain updated about the status of the motor.

According to this system, there are four units: the sensing unit, control unit, communication unit, and output unit. The sensing unit consists of current and voltage sensors, an overload relay, and a phase relay. The ESP32 microcontroller acts as the CPU, executing commands. The built-in SIM800L module provides connectivity via the GPRS network, enabling data transmission to and from the cloud. As shown in the figureIII.2

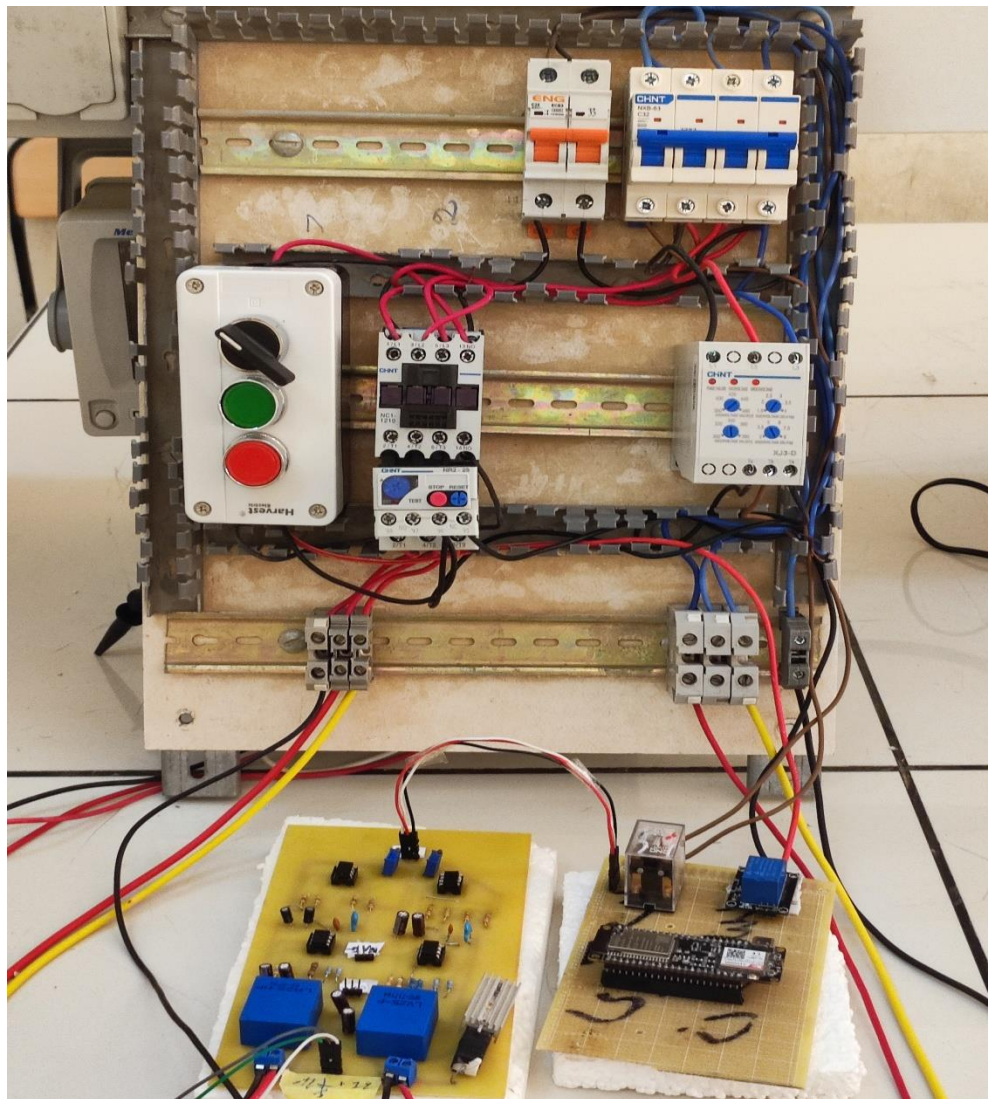

Fig III.1 proposed system

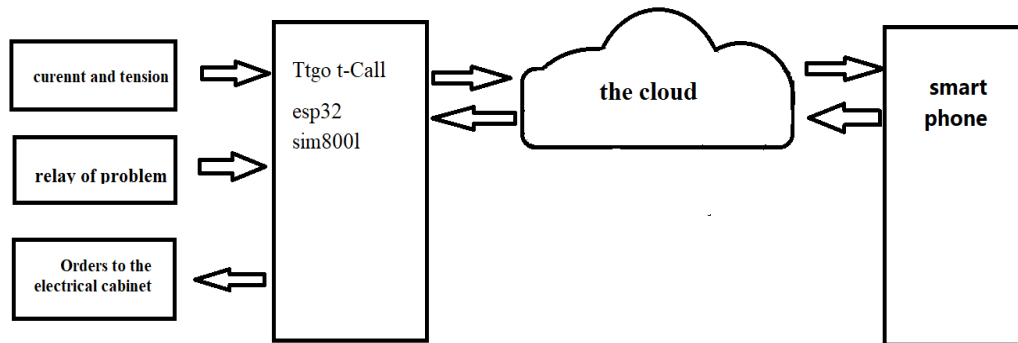

Fig III.2 Organizational chart of proposed system

III.2.1 Advantages of IOT based agriculture motor control

- It will save farmers time and money
- Farmers can control irrigation from a remote location
- Increases productivity
- Farmers can invest time in other vital tasks

The farmer can increase the area of irrigated land without difficulty

III.3 Stages of carrying out our project

To carry out our overall assembly of the system we went through several stages. These steps are grouped into two main parts.

III.3.1 First part: design and construction of the entire electronic system

III.3.1.1 Current and Voltage Sensors

A meter should measure the load current and voltage, this can be done simply using the current and voltage sensor respectively. For our prototype we used LV25 or LA 25 sensors for voltage and current, because it offers several advantages, which are:

- The circuit is light and small in size
- No saturation
- high precision

❖ LV 25-P sensor

To measure voltage across a load, we used the LEM LV 25-P type voltage sensor. This voltage sensor for it to work must be powered by ($\pm 12V$ or $\pm 15V$).

A resistor is placed at the input of this sensor such that its value depends on the value of the voltage to be measured so that the current circulating in the primary windings does not exceed 10 mA. Another resistor R_m is placed at the sensor output. Its role is to set the sensor output voltage to the desired value.

For example, in our project, the voltage coming from the sensor will power the pin which supports a voltage of 3.3 V. So the value of the resistor R_m must be chosen to ensure that the output voltage is 3.3 V .

❖ **LA 25-np sensor**

To measure the current we used a LA 25-np type current sensor which provides us with a usable voltage. This voltage will turn on pin A6 of ESP32.

LA 25-np current sensors have different measuring ranges of $\pm 5A$, ± 20 and ± 30 and the only difference between these measuring ranges is their sensitivity.

In our project, we used the LA 25-np current sensor shown in the figure, which measures 25 amps of current After studying the determination of the proportionality factor, we generated LA 25-np current sensors with an output voltage directly proportional to the current flowing in the circuit. Its value is between 0 and 3.3 V to match the ADC input of ESP32. This is an active device, meaning it requires a V_{ee} (+12 -12) voltage source to operate. [2]

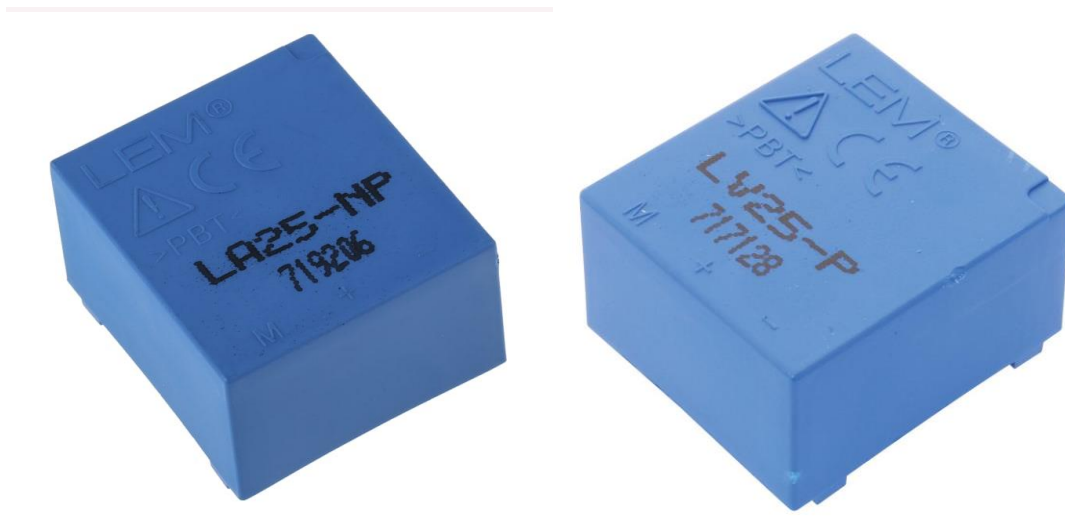

Fig III.3 LV 25 and LA25 sensors

❖ Filtering and Shifting circuits

To accurately measure AC voltage and current using LA 25 and LV 25 sensors, it is essential to implement filtering and shifting circuits. Low-pass filters are used to remove high-frequency noise, and level-shifting circuits ensure that the sensor outputs fall within the ADC range. The chosen component values and configurations ensure that the signals are clean and appropriately biased for the ESP32 microcontroller. These circuits are installed according to the following steps, as depicted in the figures III.(4-5-6).

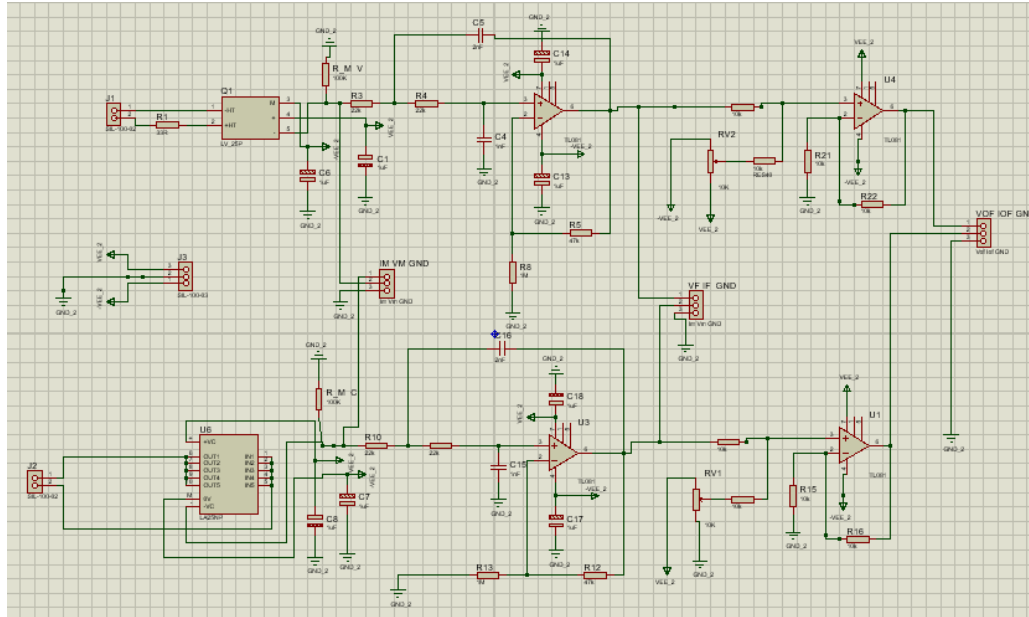

Fig III.4 schematic of sensor

We feed the sensors with (+12)and (-12)

- We connect the measuring pins LA and LV(MAX 250V/10A)
- We connect the output of the sensor M to the filter circuit in order to purify the signal from noise
- Because the measured current is alternating, the signal coming out of the sensor is alternating, so it must be raised above zero
- We connect the filtering circuit output to the shifting circuit
- The circuit output reading is 0 -3,3 to match the ESP32 input (ADS)

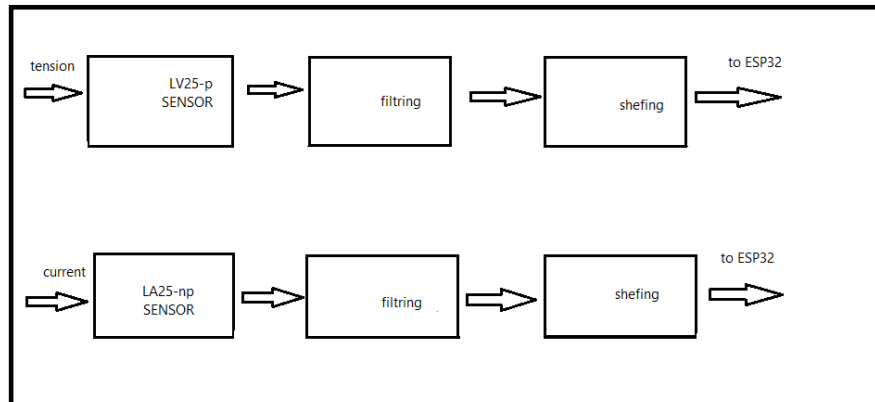

Fig III.5 working principle Current and Voltage Sensors

Circuit diagram

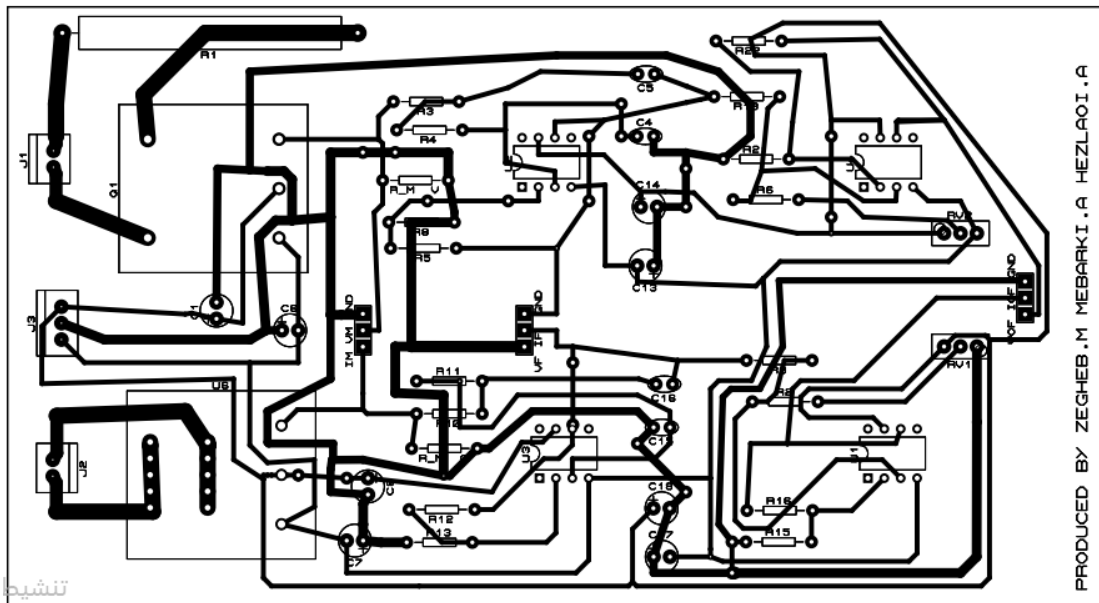

Fig III.6 circuit PCB of the sensor

Picture of the board

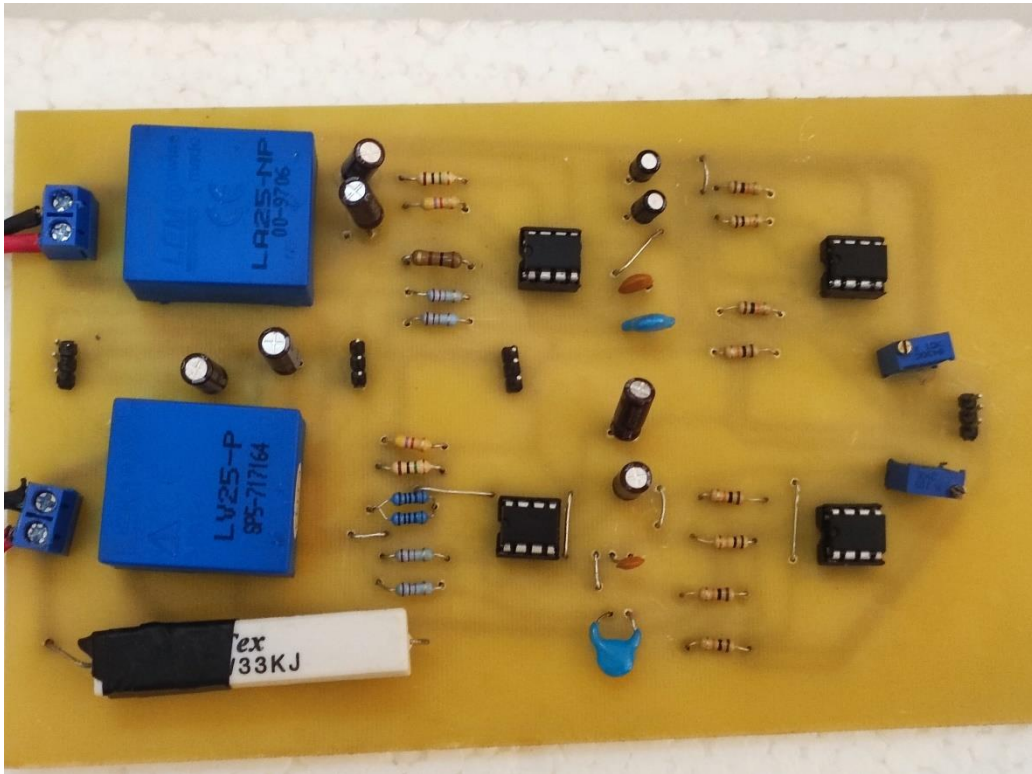

Fig III.7 board of sensor

III.3.1.2 TTGO T-Call esp32 sim8001

The proposed system employs two unique modules ESP32 and SIM8001 in a single component that is referred to as TTGO T-CALL ESP32 SIM8001. As the ESP ecosystem offers microcontrollers with GSM connectivity, we were interested in a particular model: the TTGO T-CALL ESP. The TTGO T-CALL ESP microcontroller is a new ESP32 development board associated with a module SIM800L GSM/GPRS. The new board combines ESP32 WiFi and Bluetooth with the SIMCom SIM800L GPRS and also relies on a USB-C port for power and programming. It can also be autonomous thanks to an integrated battery charger supporting batteries up to 500 mA. In addition to Wi-Fi and Bluetooth, you can communicate bidirectionally with this card by inserting a nano SIM:

- by SMS
- By phone calls
- Or by Internet if the 2G network allows it.

It is ideal for IoT projects that do not have access to a nearby router[3].

❖ **Advantages of TTGO T-Call esp32 sim800l**

The TTGO T-Call ESP32 SIM800L module offers several advantages for Internet of Things (IOT) projects:

1. **Cellular Connectivity:** It has an onboard SIM800L module that supports 2G (GSM/GPRS) cellular communications, allowing it to connect to the internet anywhere there is cellular network coverage.
2. **ESP32 CPU:** It features a high-performance, energy-efficient ESP32 chip that supports Wi-Fi and Bluetooth.
3. **Arduino Compatibility:** It can be programmed using the Arduino IDE, making it user-friendly for developers.
4. **Compact Size:** Its compact design makes it ideal for projects that require a small footprint.
5. **Longevity:** It can operate for extended periods without needing to be rebooted or maintained.
6. **Versatility:** It can be used in a variety of applications, from controlling smart devices to remote sensing applications.

Please note that a mobile phone service subscription is required to use the cellular connectivity[4].



Fig III.8 TTGO T-Call esp32 sim800l card [5]

Circuit diagram

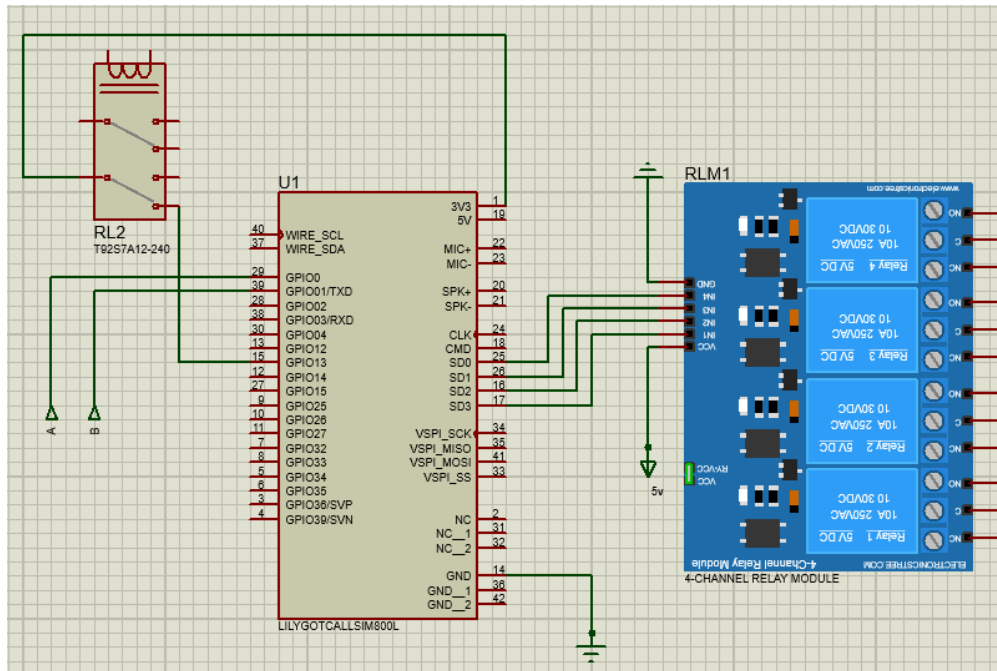

Fig III.9 Circuit diagram of esp32

III.3.2 Second part: the mobile application (Blynk)

III.3.2.1 Blynk

Blynk was designed for the Internet of Things. It can control hardware remotely, it can display sensor data, it can store data, visualize it and do many other things. There are three major components in the platform.

- Blynk application: Allows you to create fantastic interfaces for projects, using different widgets that we provide.
- Blynk Server: Responsible for all communications between the Smartphone and the Hardware. He can use the Blynk cloud or run his Server private Blynk locally. It's open-source, it can easily handle thousands of Peripheral devices.
- Blynk Library: For all popular hardware platforms, enable it communicates with the server and processes all incoming and outgoing orders [6].

❖ Blynk Apps

is a versatile native iOS and Android mobile application that serves these major functions:

1. Remote monitoring and control of connected devices that work with Blynk platform.
2. Configuration of mobile UI during prototyping and production stages.
3. Automation of connected device operations.

Applications made with Blynk are ready for the end-users. Whether they are family members, employees, or product purchasers, they can easily download the app, connect their devices, and start using them.

Blynk also offers a white-label solution as part of the Business Plan, allowing you to customize the app with your company logo, app icon, theme, colors, and publish it on the App Store and Google Play under your company's name. These customized apps will work seamlessly with your devices. [7]

❖ **Blynk Agent**

is a packaged solution designed to simplify the connection of supported devices to the Blynk platform, providing access to all its advanced features without extensive coding.

Key features of Blynk.Edgent include:

1. Device claiming and Wi-Fi provisioning (bringing device online and authenticating them with a certain user).
2. Connectivity management for Wi-Fi, Cellular, and Ethernet.
3. Data transfer between device and the cloud.
4. API integration with Blynk.Apps and Blynk.Cloud features.
5. Over-the-air firmware updates for select hardware models.

Blynk Library is a user-friendly and portable C++ library, that comes pre-configured to work with hundreds of development boards. It implements a streaming connection protocol, allowing for low-latency and bi-directional communication [7] .

❖ **Blynk Cloud**

Blynk Cloud is a server infrastructure acting as the heart of Blynk IoT platform binding all the components together.

Blynk also offers private servers.

Blynk is a multi-tenant solution that allows you to configure user access to devices and data by defining roles and permissions [7].

III.3.2.2 Getting Started With the Blynk App

Create a Blynk Account

After downloading the Blynk App, the user needs to create a New Blynk account with a valid email address. Why do the users need to create an account?

- An account is required to save user's projects and have access to them from multiple devices from anywhere in the world
- It's also a security measure
- The users can always set up their own Private Blynk Server and have full control.

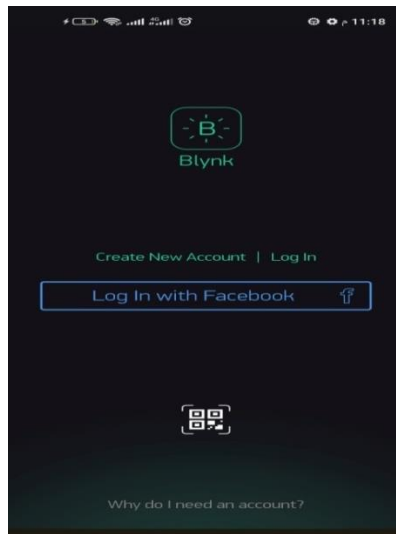

Fig III.10 Log in to BLYNK app

❖ Create a New Project

After successfully logged into the account, the next step is to start by creating a new project.

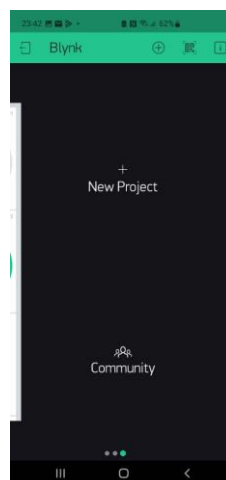

Fig III.11 Create a New Project

❖ Choose Hardware

User need to select the hardware model to be used. Blynk supports more than 400 boards already, including support for Arduino, ESP8266 (Generic, NodeMCU, Witty Cloud, Huzzah, WeMos D1, Seeed Wio Link, etc.), ESP32 (WiFi, BLE), Raspberry Pi, BeagleBone Black, Particle, ARM mbed, TI Energia, MicroPython, Node.js, OpenWRT and many Single Board Computers[8].

Auth Token

Auth Token is a unique identifier for the user which is needed to connect their hardware to their smartphone. Every new project a user creates will have its own Auth Token. Users will get Auth Token automatically on their email after project creation. They can also copy it manually. Click on devices section and selected required device [8].

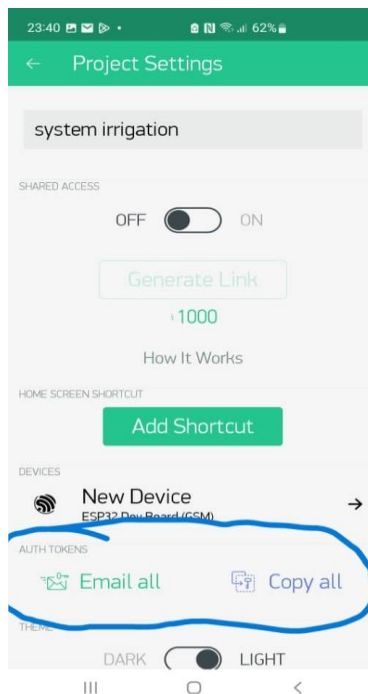

Fig III.12 Getting Auth Token

Add a Widget

User will find the project canvas empty and thus required to add widgets or blocks to their project. For that purpose user needs to tap anywhere on the canvas to open up the widget box. All the available widgets are located here. Users need to pick and place the widget of their choice.

- Drag-n-Drop – User need to tap and hold the Widget to drag it to the new position

- **Widget Settings** - Each Widget has its own settings and user need to tap on the widget to get to them. The most important parameter to set is PIN. The list of pins reflects physical pins defined by the user's hardware. If the LED is connected to Digital Pin 8, then select D8 where D means Digital[8].



Fig III.13 Widget box

❖ **Run the Project**

After done with the Settings the user need to press the PLAY button. This will switch the project from EDIT mode to PLAY mode where the user can interact with the hardware. While in PLAY mode, it will never allow the user to drag or set up new widgets, press STOP and get back to EDIT mode if required. When the connection will establish the Blynk dashboard will show a message “ESP32 is online” otherwise user will get a message saying “ESP32 is offline” [8].

III.4 Practical test

The water pump is the basic component of the irrigation system.

Electrical control cabinet

In order to control the pump, we need an electrical control cabinet. The cabinet is installed according to the power of the pump motor. In this experiment, we will use a powerful motor (3 kw, 5 horsepower). Its total current consumption is (7.2A), so we will need the following components:

- Magnetic thermal breaker (MCB) 32 A
- Contactor D12
- Thermal relay (overload) 5.5-8 A
- Phase relay (CHINT XJ3-D)
- Control buttons (start and stop button and select switch)

Installing the current and tension sensor

- We connect the current sensor side in series with the power circuit and the voltage sensor side in series between phase and neutral.
- We feed the sensor card with (-12 V GND +12 V)
- We connect the sensor outputs (V A GND) to the ESP32 card at the A0 A3 GND PIN

Connecting relays

- We connect the fault relay feeder between the neutral and the phase relay output
- We connect the control relay between the phase and the contactor in series with the selector switch

Blynk

- After logging in to my account on the Blink application, we choose to add a new project
- We choose the card type, ESP 32, and the connection type we choose GSM

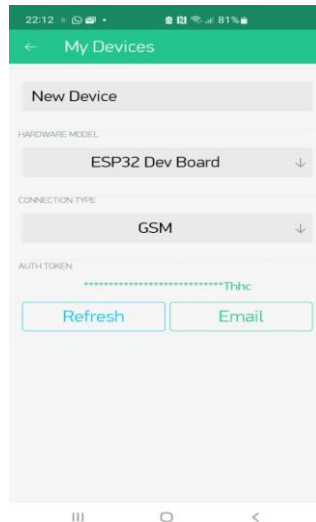

Fig III.14 choose the card type

- We receive the token in the email address

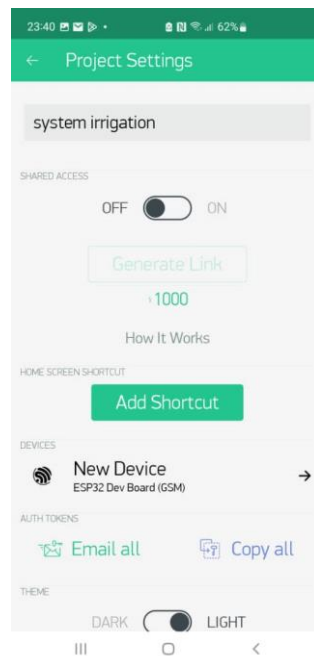

Fig III.15 receive the token

- We choose from the list **Widget Box** the appropriate tools
- We put an indicator to display the value of current and voltage

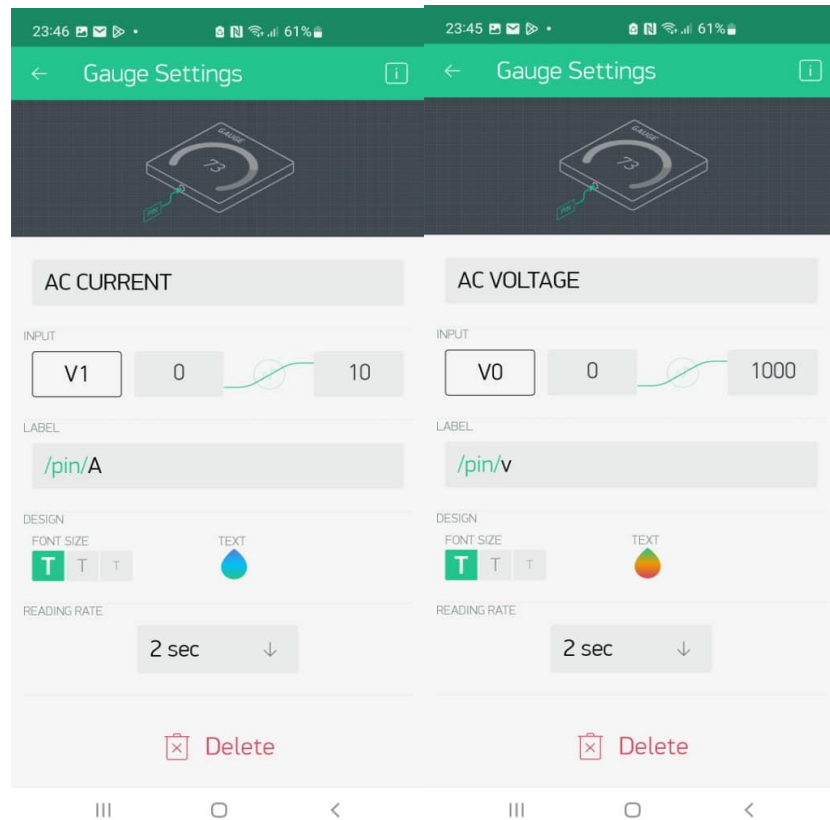

Fig III.16 add to display the value of current and voltage

- We put an LED light to display the phase status

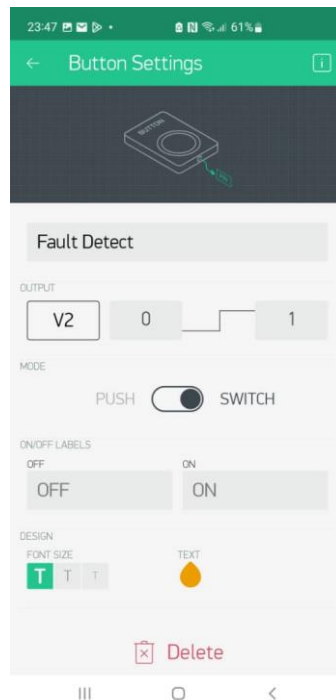

Fig III.17 LED light to display the phase status

- We set the notification settings and set the notification tone from the phone

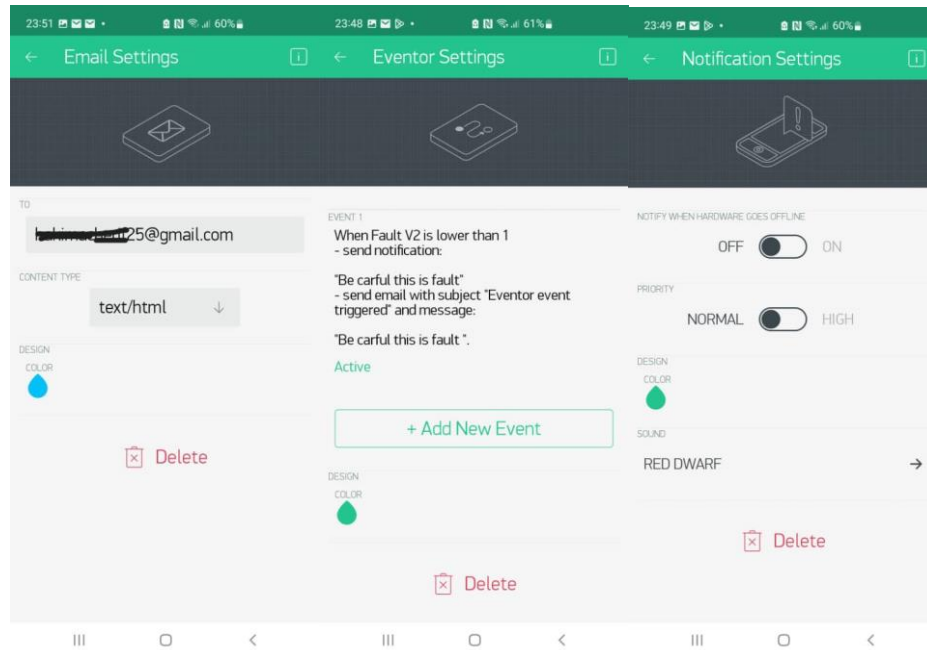

Fig III.18 notification settings

- We set the **SuperChart** settings in order to save AC voltage and AC current data and display it in the form of a curve

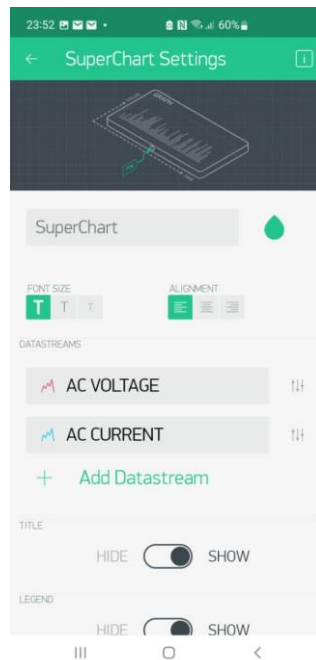

Fig III.19 SuperChart settings

- We place the control buttons to turn the pump on and off

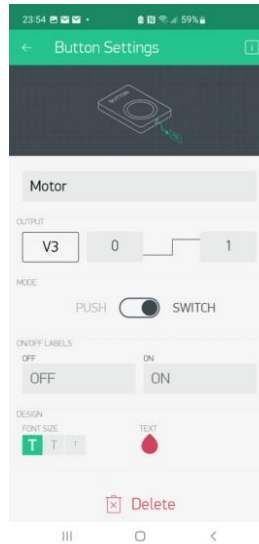

Fig III.20 the control buttons

System startup

- We place a SIM card in the ESP32 card and ensure its connection to the Internet
- We also ensure that the mobile phone is connected to the Internet via Wi-Fi or 4G
- We open the Blink application on the phone and make sure it is connected to the system via the cloud
- You will see in the application interface the value of the tension available to the motor
- You can open and close the engine by pressing the ON OFF button
- You will see the value of the current consumed
- In the event of a phase error or overload. An error indicator will appear in the application interface with a notification and sound, and the notification will also be sent to the e-mail.

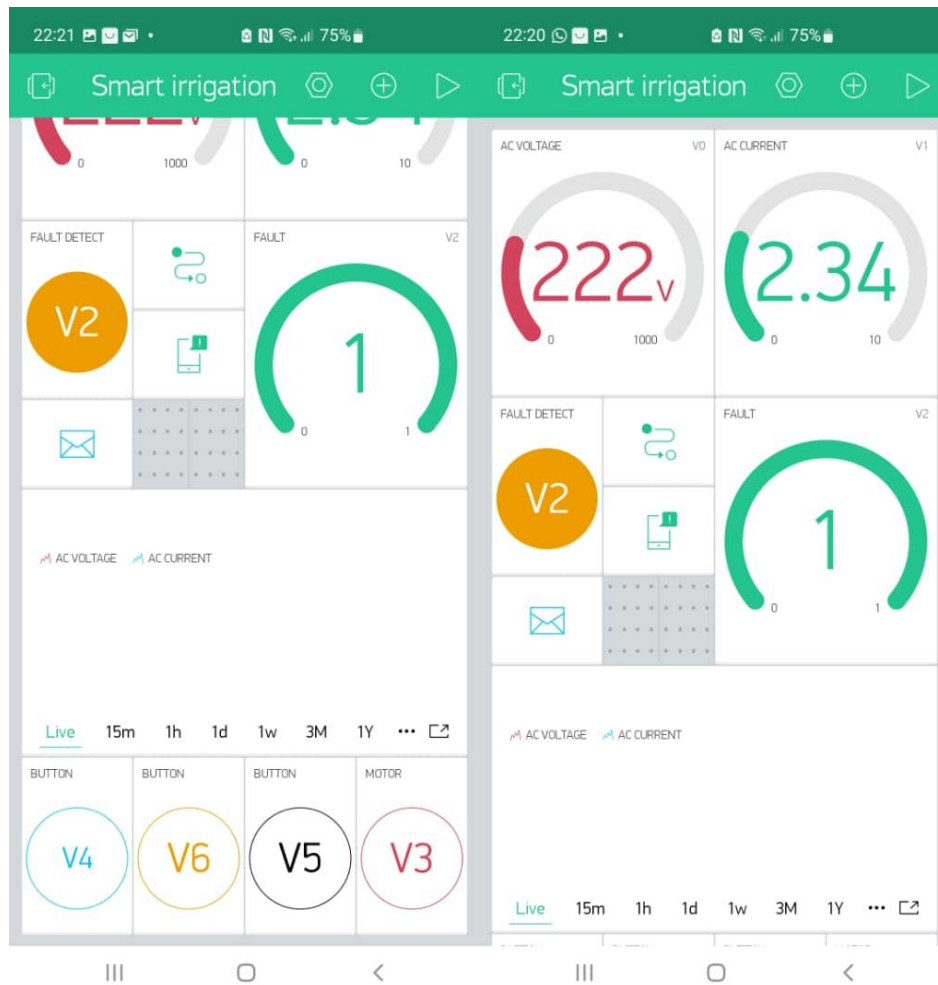

Fig III.21 Application interface

III.5 The Test results and discussion

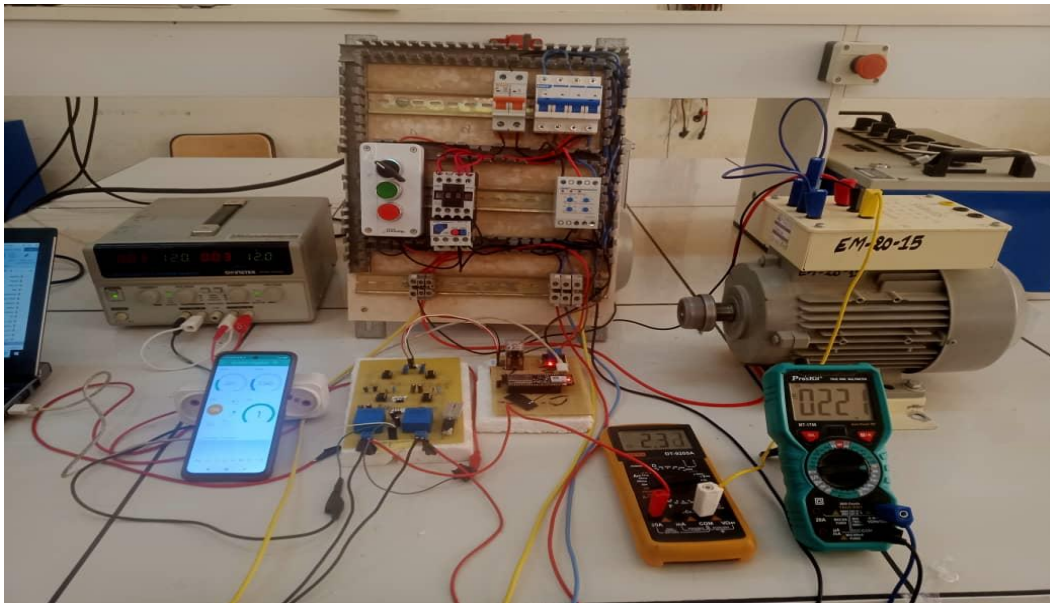
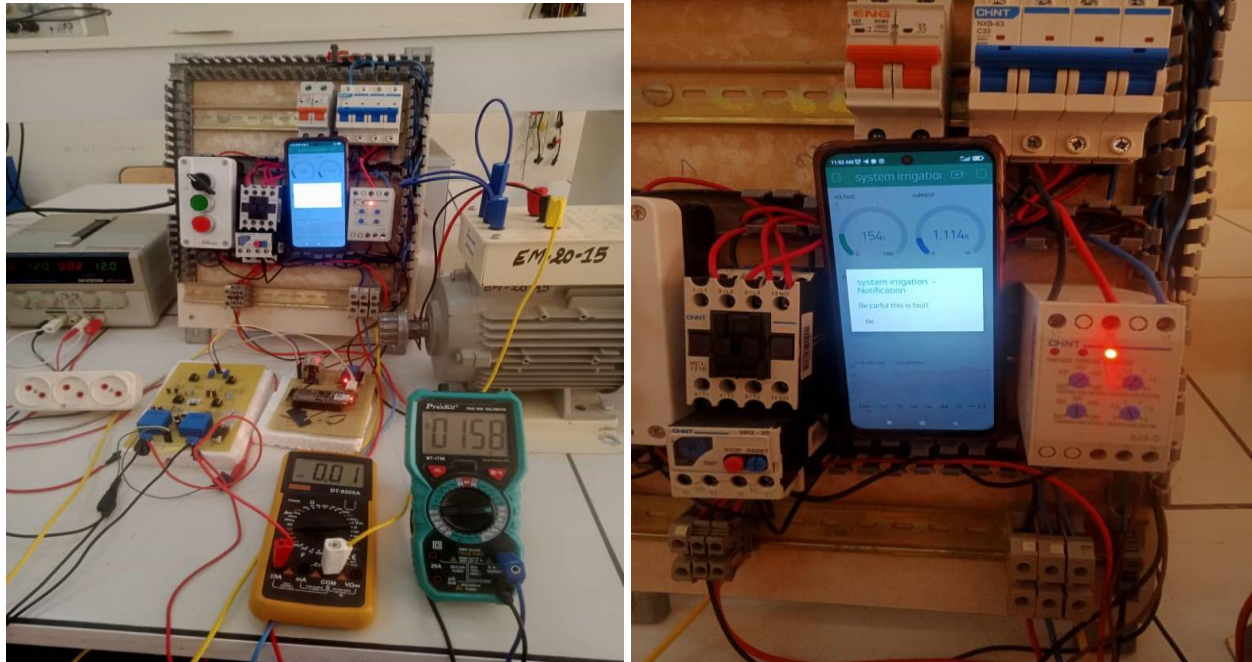

Fig III.22 The system in healthy state



Figs III.23 & 24 The system in overvoltage state



Figs III.25 & 26 The system in undervoltage state

Fig III.22 depicts our system under normal conditions (healthy state). The system functions properly, and the readings shown on both the voltmeter and ampermeter match those displayed on the Blynk app.

Figs III.(23&24) represent System under Overvoltage fault .An overvoltage fault has been detected on the motor by the monitoring system proposed ,where The system has automatically shut down and sent a notification to your phone stating: "Be careful, this is a fault".

Figs III.(25&26) illustrate the system under Undervoltage fault. The monitoring system identified that the motor was affected by an overvoltage condition. As a result, the system initiated an automatic shutdown and sent a notification to your phone with the message: "Be careful, this is a fault".

III.6 Conclusion

In conclusion, the implementation of an intelligent monitoring system for a water pump using the ESP32 microcontroller with SIM800L GSM/GPRS module marks a significant advancement in agricultural technology. This system addresses the longstanding challenge faced by farmers in managing irrigation systems efficiently. By leveraging IoT capabilities, farmers can now remotely

control and monitor their water pumps through a user-friendly Android application, eliminating the need for daily physical presence at remote fields.

The system's architecture, as outlined in this chapter, incorporates essential components such as current and voltage sensors, relays, and a robust protection algorithm programmed into the ESP32 microcontroller. These components work together seamlessly to ensure the reliable operation of the 3-phase induction motor while providing real-time feedback and alerts to the user via SMS notifications.

Key advantages of this IoT-based solution include significant time and cost savings for farmers, increased agricultural productivity through optimized irrigation management, and the ability to expand irrigated land without geographical constraints. The integration of Blynk platform further enhances usability, allowing intuitive control and monitoring functionalities through a mobile application.

III.7 References

- [1] IoT Based Remote Monitoring, Control, and Protection of Irrigation Water Pumping System *M. K. Kirar* 1, Apr. 2023
- [2] <http://dspace1.univ-tlemcen.dz/handle/112/11570> date : 27/05/2024 at 10:00 AM
- [3] Design of an IoT Platform for a Precision Agriculture (PA) in Burkina Faso
- [4] Copilot chat GPT
- [5] data sheet TTGO T-Call V1.4
- [6] Y. Ait Mouhoub et F.Bouchebbah , « Proposition d'un modèle de confiance pour l'Internet des objets ». Mémoire master de l'université Abderrahmane Mira Bejaia,
- [7] <https://docs.blynk.io/en> date : 28/05/2024 at 7:00 PM
- [8] 'Blynk' Cloud Server based Monitoring and Control using 'NodeMCU' Ms. Priya Sharma¹, Mr. Parveen Kantha² 10 | Oct 2020

General

Conclusion

General Conclusion

The thesis outlines the significance of irrigation systems in agriculture, the common faults encountered in water pumps, and the advantages of using intelligent monitoring systems. Here's a summary of the key points:

1. Irrigation Systems Overview:

- Irrigation systems are crucial for agriculture, particularly in areas with water scarcity. They ensure the regular and adequate supply of water to crops, thus enhancing productivity and yield.

2. Water Pump Faults:

- Water pumps, integral to irrigation systems, can experience various faults that compromise their efficiency and reliability. Common issues include thermal overload, voltage unbalance, and other induction motor faults. These faults can lead to disruptions in irrigation, reduced crop yields, and increased operational costs.

3. Intelligent Monitoring Systems:

- The adoption of intelligent monitoring systems in irrigation addresses these faults effectively. These systems use IoT and advanced computational methods to provide real-time monitoring, early fault detection, and predictive maintenance. Key benefits include:
 - **Early Fault Detection:** Allows for timely maintenance and repairs, minimizing downtime and preventing minor issues from becoming major failures.
 - **Enhanced Efficiency:** Ensures pumps operate at optimal efficiency by making real-time adjustments.
 - **Cost Savings:** Reduces the need for expensive emergency repairs and extends the lifespan of pump components.
 - **Data-Driven Decision Making:** Provides valuable data for informed decision-making regarding pump operations, maintenance schedules, and system upgrades.

4. Implementation of Intelligent Monitoring Systems:

- The thesis discusses the implementation of an intelligent monitoring system using ESP32 with the SIM 800L. This system demonstrates the

General Conclusion

practical application of IoT in monitoring and managing water pumps in irrigation, showcasing its potential to transform agricultural practices through improved efficiency and sustainability.

In conclusion, understanding the intricacies of irrigation systems and the impact of pump faults is essential for maintaining effective agricultural practices. The integration of intelligent monitoring systems offers a proactive approach to managing these systems, ensuring sustainability and enhanced productivity in agriculture.