



University of Echahid Hamma Lakhdar El Oued
Faculty of Technology



Final Master Thesis in order to obtain the diploma of

ACADEMIC MASTER DEGREE

Domain : Sciences and Technology

Branch : Electrical Engineering

Speciality : Electric Control

Subject

Control of Grid-Forming Three-Phase
Inverter based on a Double Closed-Loop
Proportional-Integral

Realized by:

Aymen GUEDDA

Mohamed KERMADI

Zakaria BAHI

Supervisor :

Pr. Zoheir TIR

June 2021



Control of Grid-Forming Three-Phase Inverter based on a Double Closed-Loop Proportional-Integral

Abstract

this work presents in this brief concerns the photovoltaic inverter forming. This system is subject to significant developments linked mainly to an increasingly manifested desire to diversify the means of energy production, particularly in Algeria, and better respect for the environment. Associated with decentralized production, these small or medium-sized units can allow an advantageous pooling of widely distributed resources. Very fluctuating, and contribute to better management of electrical energy in a context of sustainable development. The interest in renewable energies led us to look at photovoltaic inverters as decentralized production. These systems use converters to connect to the power grid and the power injected is highly variable since it is dependent on lighting and temperature. A bibliographic study made it possible to identify the different photovoltaic systems that can be connected to the network. Our work of simulation, realization and study of the connection to the different load on islanded mode comes down to a DC / DC converter of the interlaced Boost type which supplies a direct voltage. This converter has the advantage of being a voltage booster by minimizing current ripples which allows the system to adapt to weather changes and to extract the maximum available power and another DC / AC converter controlled by the PWM which converts the direct voltage to an alternating voltage filtered by an LC filter and they were modeled and simulated using Matlab-SIMULINK 2014a. The results of the simulation demonstrated the value of an interlaced device. From this study emerges the importance of the modeling of the connection to the electrical network with linear and nonlinear load in normal and abnormal condition. The control of the inverter and the production systems determine the main behavior of the energy production on the low voltage grid. Current technologies controller like PI and Hysteresis provide great control flexibility and even adapt to network faults such as abnormal condition: voltage swells and swags and thus not be disconnected from the network. And finely we have studied the output current of two controllers and gives a comparison based on fast dynamic response and ease of implementation and current quality. Keywords: : dSPACE, (DSP) Digital signal processor, Three-phase inverter, PWM pulse width modulation, (SPWM) Sinusoidal Pulse Width Modulation, (SVPWM) Space Vector Pulse Width Modulation, (SHE) Selective Harmonic Elimination, (THD) Total Harmonic Distortion, MATLAB/Simulink,grid-forming,dpgs,production generator.

Control of Grid-Forming Three-Phase Inverter based on a Double Closed-Loop Proportional-Integral

الملخص:

يعرض هذا العمل موجزا والذي يتعلق بتشكيل المذبذب. وخضع هذا النظام لتطورات مهمة مرتبطة بشكل أساسي برغبة واضحة متزايدة لتنويع وسائل إنتاج الطاقة المتجددة، لا سيما في الجزائر، واحترام أفضل للبيئة. يمكن لهذه الوحدات الصغيرة أو المتوسطة، المقترنة بالإنتاج اللامركزي، أن تسمح بتجميع مفيد للموارد الموزعة على نطاق واسع. ويساهم في إدارة أفضل للطاقة الكهربائية في سياق التنمية المستدامة. دفعنا الاهتمام بالطاقات المتجددة إلى النظر إلى المحولات الكهروضوئية على أنها إنتاج لامركزي. تستخدم هذه الأنظمة محولات للاتصال بشبكة الطاقة وتكون الطاقة المحقونة متغيرة للغاية لأنها تعتمد على الإضاءة ودرجة الحرارة. أتاحت دراسة بليوغرافية تحديد الأنظمة الكهروضوئية المختلفة التي يمكن توصيلها بالشبكة. إن عملنا في محاكاة وإدراك ودراسة الاتصال بالحمل المختلف في وضع المعزول وينزل إلى محول DC / DC من نوع Boost المتشابك الذي يوفر جهدًا مباشرًا. يتميز هذا المحول بكونه معزلاً للجهد عن طريق تقليل تموجات التيار مما يسمح للنظام بالتكيف مع تغيرات الطقس واستخراج أقصى طاقة متاحة ومحول تيار مستمر / تيار متردد آخر يتحكم فيه PWM والذي يحول الجهد المباشر إلى جهد متناوب مرشح بواسطة مرشح LC وتم تصميمها ومحاكاتها باستخدام Matlab-SIMULINK 2014a أظهرت نتائج المحاكاة قيمة الجهاز المتشابك. من هذه الدراسة تظهر أهمية نمذجة الاتصال بالشبكة الكهربائية ذات الحمل الخطي وغير الخطي في الظروف العادية وغير العادية. يحدد التحكم في العاكس وأنظمة الإنتاج السلوك الرئيسي لإنتاج الطاقة على شبكة الجهد المنخفض. توفر وحدة التحكم في التقنيات الحالية مثل PI و Hysteresis مرونة كبيرة في التحكم بل وتتكيف مع أخطاء الشبكة مثل الحالة غير الطبيعية: تضخم الجهد والتخفيضات وبالتالي لا يتم فصلها عن الشبكة. ودرسنا بشكل دقيق تيار الإخراج لوحدتي تحكم وأعطينا مقارنة بناءً على الاستجابة الديناميكية السريعة وسهولة التنفيذ والجودة الحالية.

الكلمات المفتاحية: معالجات الشارة الرقمية، موج ثلاثي الأطوار، تقويم عرض: كلمات مفتاحية مسبقاً، معدل النبض جيب-مثلث، تقويم عرض النبض الشعاعي، تقويم عرض النبض بزوايا محددة التوشو التوافقي

Acknowledgements

We want to thank Allah, who gave us patience, and strength and assistance in achieving such scientific research.

First of all, we would like to thank Pr.Tir Zoheir very much for his guidance and support throughout the research and for reading and commenting on this thesis.

Special thanks to the Prof. Farhat Rhouma director of LEVRES Laboratory and the Mr Othman Guedda engineer at level of Laboratory of LEVRES

Thank you especially for our families. Thank you for supporting us for everything. Thank you for encouraging us throughout this experiment. Thank you for keeping us in this position.

Control of Grid-Forming Three-Phase Inverter based on a Double Closed-Loop Proportional-Integral

Table of Contents

abstract.....	i
Acknowledgements.....	iii
Table of Contents	iv
Table of Figures.....	vi
List of Tables	vii
I.1.Introduction	1
I.2.Photovoltaic systems:	1
I.3. Classification of grid-connected PV inverter systems:	2
I.4.Structure of distributed power generation DG:.....	3
I.5.Three phase grid Inverter DC/AC:.....	4
I.6.Classification of Outer Control Loops for DPGS:	5
I.6.1. Control of Grid-Forming Power Converters:	5
I.6.2. Control of grid-feeding power converters:	6
I.8.Grid Synchronization Method:	9
I.8.1. Phase Locked Loop (PLL).....	10
I.9.Power Quality (Abnormal Situations):	10
I.9.1. Voltage Sags:	11
I.9.2. Voltage Swell:.....	11
I.10. Chapter Summary:.....	11
II.1. Introduction:	12
II.2. Pulse width modulation (PWM):	12
II.2.1. Sine pulse width modulation (<i>SPWM</i>)	13
II.2.2. Harmonic analyses:	15
II.3. Overview of inner control loops:	17
II.3.1. Basics of current control:.....	17
II.3.2. Hysteresis Current Control:	18
II.3.4 Classical pi controller.....	19

Control of Grid-Forming Three-Phase Inverter based on a Double Closed-Loop Proportional-Integral

II.4. Proposed Experimental Module (Grid-Forming Mode Control):.....	20
II.4.1. Synchrones frame d-q Transformation :	21
II.4.2. Phase-Locked Loop (PLL) :	22
II.4.3. Voltage Control	22
II.4.4.PWM Generation:	24
II.5. Chapter Summary:.....	25
III.1. Introduction:	26
III.2. SIMULATION AND LABORATORY SETUP PARAMETERS:.....	27
.....	27
III.3. Proportional Integral (PI) Current Controller:.....	27
III.4. Simulink model of the three-phase grid-forming inverter with PI Controller:.....	28
III.5. Simulink model of the three-phase grid-forming inverter with Hysteresis Controller:.....	29
.....	29
III.6. Control of system based on Hysteresis technique:.....	30
III.6.1. Hysteresis controller under normal grid conditions:.....	30
III.6.2. Hysteresis controller under abnormal grid conditions.....	32
III.7. Control of system based on SPWM technique:.....	35
III.7.1. PI controller under abnormal grid condition:	35
III.8. Experimental Results:.....	43
III.8.1. The dSPACE:	43
III.9. Chapter Summary:.....	47
References:	48

Control of Grid-Forming Three-Phase Inverter based on a Double Closed-Loop Proportional-Integral

Table of Figures

Fig n°1: Solar PV global capacity and annual additions, 2007-2017. [2].....	2
Fig n°2: Classification of PV systems [2].....	3
Fig n°3: General structure for distributed power system [3]	4
Fig n°4: Three phase grid Inverted [4]	5
Fig n°5: Basic control scheme of a grid-forming voltage source inverter [3].....	6
Fig n°6: Basic control scheme of a grid-feeding voltage source inverter [3]	7
Fig n°7: Basic control scheme of a Grid-supporting power converter operating as a voltage source [3].....	8
Fig n°8: Basic Filter Topologies: -a-Filter L, -b-Filter LC, -c-Filter LCL.[5].....	9
Fig n°9: PLL Scheme [4]	10
Fig n°10: Sinusoidal PWM technique [8].....	13
Fig n°11: Voltage modulation range for SPWM. [8]	14
Fig n°12: SPWM technique for a three-phase inverter. [8]	15
Fig n°13: Frequency spectrum of the pole voltage for the SPWM [8]	16
Fig n°14: Frequency spectrum of the line-to-line voltage for the SPWM (MI 5 0.8, mf 5 21). [8].....	17
Fig n°15: Principle of hysteresis control: current (upper) and converter output voltage(lower) [12].....	18
Fig n°16: The block diagram of hysteresis current control [12]	19
Fig n°17: the block diagram of dq cross-decoupling current control scheme [13]	20
Fig n°19: Grid-Forming Mode Control [3]	21
Fig n°20: Block diagram of PLL [13]	22
Fig n°21: Voltage Control outer loop scheme. [13].....	23
Fig n°22: a,bcontrol of voltage in dq frame by using two different PI controllers.[13]	23
Fig n°23: stand-alone grid connected inverter [13]	24
Fig 24: PWM generation scheme using dq transformation [13].	25

Control of Grid-Forming Three-Phase Inverter based on a Double Closed-Loop Proportional-Integral

Fig n°25: Simulink model of the three-phase grid-forming inverter with hysteresis Controller.	29
Fig n°26: Simulink model of the three-phase grid-forming inverter with PI Controller	30
Fig n°27: Synchronous Reference Frame Voltage v_{dq} (Hysteresis)	31
Fig n°28: Synchronous Reference Frame Current I_{dq} (Hysteresis).....	32
Fig n°29: DC Voltage V_{dc} (Hysteresis).....	32
Fig n°30: Synchronous Reference Frame Voltage v_{dq} (Hysteresis).	33
Fig n°31: Synchronous Reference Frame Current of the inverter I_{dq} (Hysteresis).	34
Fig n°32: Switching frequency (Hysteresis).....	34
Fig n°33: Synchronous Reference Frame Voltage v_{dq}	36
Fig n°34: Synchronous Reference Frame Current Inverter I_{dq}	37
Fig n°35: Synchronous Reference Frame Voltage v_{dq} of the load (PI)	38
Fig n°36: Synchronous Reference Frame Current I_{dq} of the load (PI)	38
Fig n°37: Synchronous Reference Frame Voltage V_{dq} Inverter (PI)	39
Fig n°38: Synchronous Reference Frame Current I_{dq} Inverter (PI)	39
Fig n°39: Three-phase grid-forming inverter test rig.	41
Fig n°40: Three-phase Voltage and angle.	42
Fig n°41: Three-Phase Load Voltage and Frequency (Frequency decreasing) ...	42
Fig n°42: Three-Phase Load Voltage and Frequency (Frequency Increasing)	43
Fig n°43: Three-phase Voltage and Switching Frequency	43
Fig n°44: Three-phase Voltage and Frequency	44

Control of Grid-Forming Three-Phase Inverter based on a Double Closed-Loop Proportional-Integral

List of Tables

Table n°1: Output voltage of the inverter.....	14
Table n°2: Parameters and variables of the VSI	21
Table n°3: SIMULATION AND LABORATORY SETUP PARAMETERS.....	27

I.1.Introduction

Electricity demand for commercial, industrial and household loads in rural, semi-urban and urban areas has grown significantly over the years. Due to higher energy consumption, the demand for sustainable energy is increasing and more grid-connected systems are used. However, when such systems are widely used, harmonic pollution of their output current cannot be ignored. According to the relevant standards, the total harmonic distortion of the inverter grid-tied current should be less than 5%, and any harmonic distortion should be less than 3%. Most distributed resources are networked through an isolation transformer. Power supply facilities require the elimination of zero sequence potential or DC components in the generated voltages and for better protection. This fact can be used to advantage because the transformer can be part of the filter impedance and thus can reduce the unwanted harmonic content of the output current. Digital control of power electronics has been widely used in the past decade [1].

The trend towards modular construction of power electronic systems can increase power capacity and also improve system efficiency. The power quality of the grid inverter is an important factor, especially in high power applications. The power quality is determined by the voltage quality, when the voltage is a controllable variable. If there is a connection to an existing network, the voltage cannot be regulated. The grid quality is then determined by the current quality. [1]

In this chapter, the main review of the micro grids, grid synchronization method, furthermore a comparison between grid filter types are presented. Moreover, a three-phase grid-forming inverter have been discussed, followed by grid-forming system model have been in order to get deep understand of the system. besides discussing different type of outer control loops for DPGS such as Control of grid-forming, grid-feeding, grid-supporting power converters.

I.2.Photovoltaic systems:

In particular, photovoltaic PV systems which utilize solar power to generate electricity, have shown significant growth in recent years, with an average annual rate of increase of 60%. This has been driven by the increasing efficiency

and reductions in the cost of PV modules. For instance, it has been reported that PV capacity in 2017 had increased by a factor of 43.14 from just 8 GW in 2007 to a new record figure of 400GW worldwide in 2018, as depicted in the cumulative global installation data given in Fig n°1 [2].

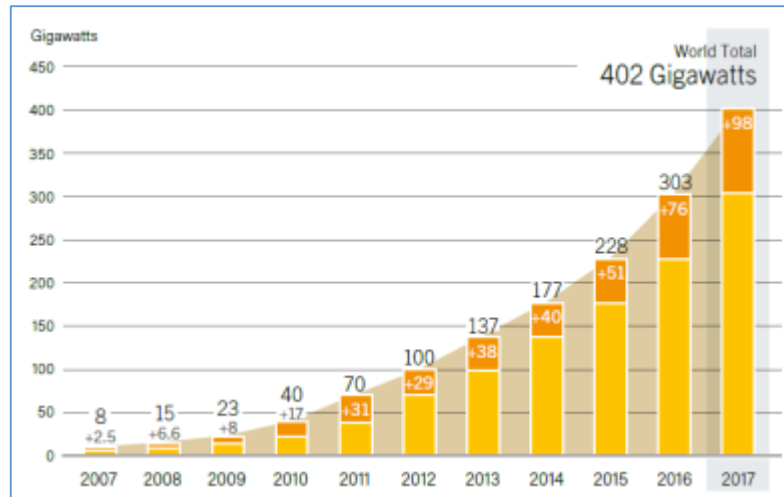

Fig n°1: Solar PV global capacity and annual additions, 2007-2017. [2]

The installation of solar PV conversion systems is expected to grow faster, encouraged by cost savings, technology development and increased efficiency. The International Energy Agency (IEA) predicts that by the end of 2050, about 16% of global electricity will be provided by solar PV systems. The share of installed PV capacity includes grid-connected PV systems, which is over 99% compared to off-stand-alone systems on the network. However, the number of stand-alone systems is growing rapidly [2]

1.3. Classification of grid-connected PV inverter systems:

In general, PV systems can be divided into two main categories: stand-alone and grid-connected systems (as shown in Fig n°2). The first is used to supply local loads, such as housing, without any interaction with the public grid. Energy storage devices, such as batteries, are usually required in stand-alone systems to meet demand during periods of low radiation during the day or night. On the other hand, grid-connected photovoltaic systems that are within the current search range, are connected to the distribution system, as well as to the local loads. Thus, grid-connected PV systems must operate in grid-connected mode under normal operating conditions, and off-grid mode in emergency situations, such as system outages. The change between the two

modes must be smooth and uninterrupted to provide reliable and safe operation of the entire system [2].

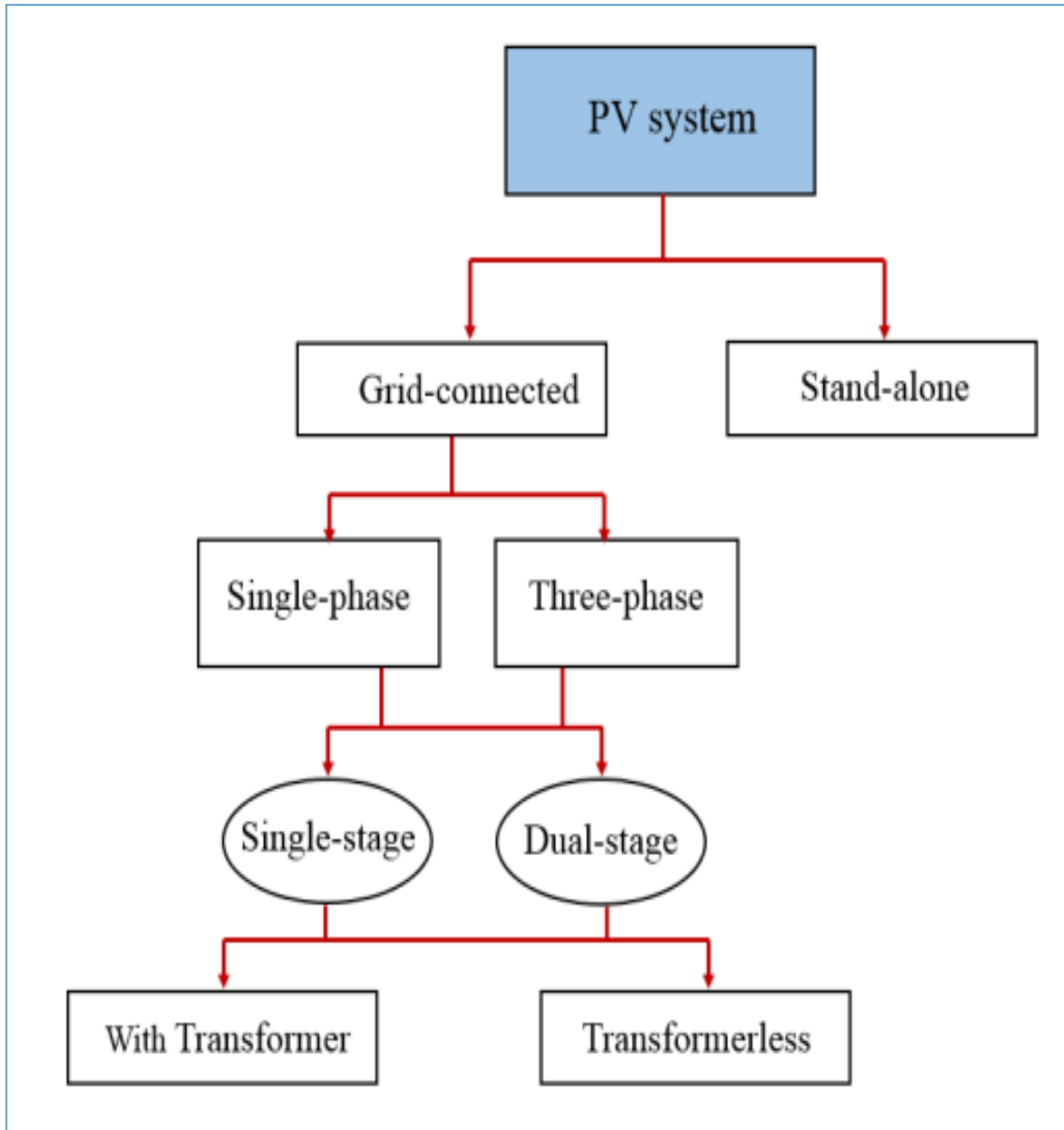

Fig n°2: Classification of PV systems [2].

1.4. Structure of distributed power generation DG:

Electricity generated from stations that are Small enough to central power plants to make this possible Interconnection at nearly every point in the power grid which include in case of double stage: source generation input like photovoltaic, DC-DC converter, DC-AC inverter, filter (L, LC, LCL.), load

Recently, the LCL filter has been widely applied to networked switches. Fig n°3. shows the general structure that contains different input power sources.

The Distribution Generation Unit (DG) can be connected to the public network through a single common connection point (PCC). It is responsible for generating electricity and must be able to import/export energy from/to the grid, control active and reactive energy flows, and manage energy storage [3].

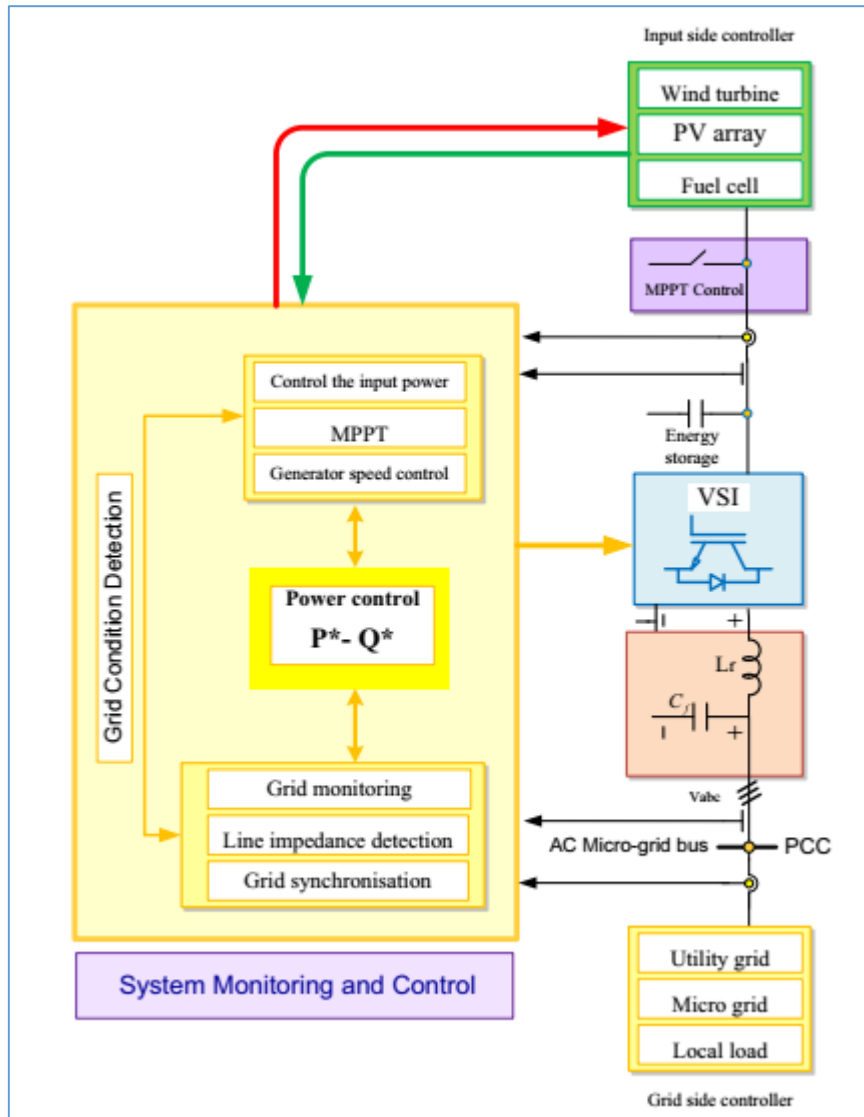

Fig n°3: General structure for distributed power system [3]

1.5.Three phase grid Inverter DC/AC:

A three-phase inverter connected to the grid is used to interconnect the photovoltaic panels that generate a direct voltage in an alternating voltage suitable for the public grid. Fig 4 shows Three phase grid Inverted.

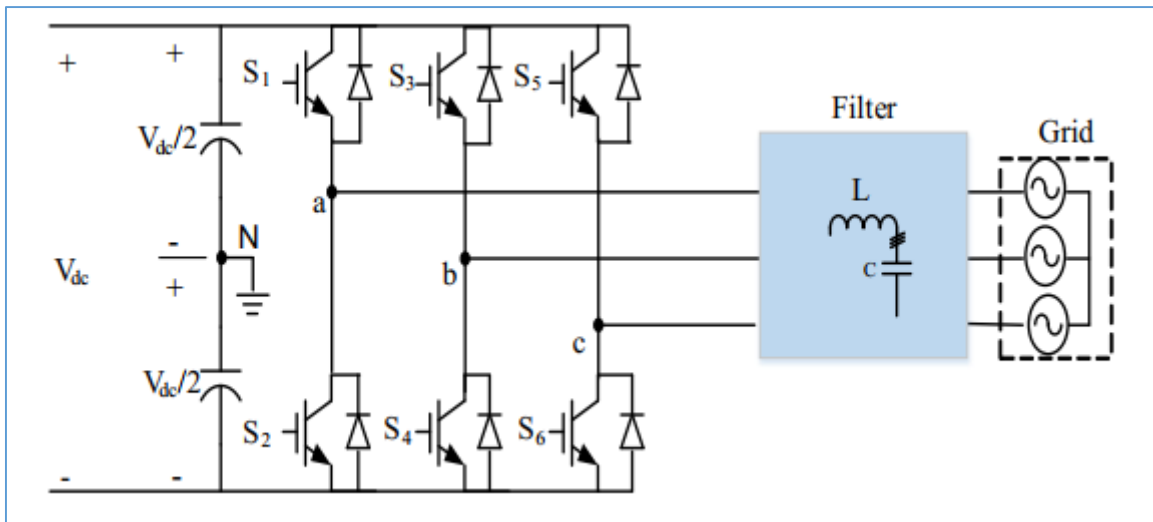

Fig n°4: Three phase grid Inverted [4]

1.6. Classification of Outer Control Loops for DPGS:

The inverter connected in parallel with the grid is controlled to exchange energy between the grid and the DPGS, the inverter contributes to the formation of the grid voltage and frequency. The power inverters are classified in three classes: grid-forming, grid-supporting and grid-feeding [3]:

1.6.1. Control of Grid-Forming Power Converters:

Grid Forming transformers are power transformers designed for independent operation, shown as constant frequency AC voltage sources. The control scheme has two sequence control loops in the reference frame d-q, the outer loop is responsible for voltage regulation and the inner loop is related to current regulation. In such type of control scheme, the amplitude of the voltage on the PCC and the current are measured and converted to DC values in the d-q frame by applying the Park transformation and compare them with the reference values. It is possible to decouple the active and reactive components based on the d-q reference selection, it is clear that the current i_d controls the active component, while the current i_q controls the reactive component. Moreover, when choosing the reference, the amplitude of V_q has a zero value while V_d has the same amplitude as the reference voltage. Fig n°5 shows the basic circuit diagram for a grid forming power converter in three phases [3]

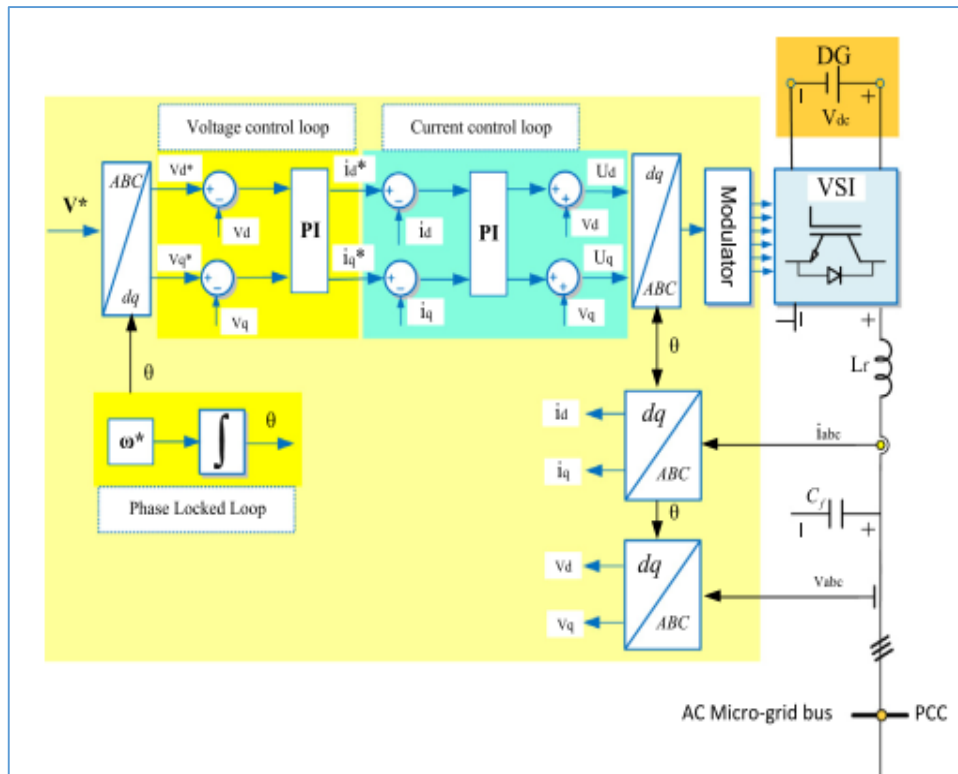

Fig n°5: Basic control scheme of a grid-forming voltage source inverter [3]

This type of grid systems, we'll study it deeply in the coming chapters.

1.6.2. Control of grid-feeding power converters:

The grid-feeding power converters are suitable for parallel operation with other mains power inverters in grid interconnect mode. In fact, most power inverters belonging to DG systems operate in grid-feeding, such as in PV or wind power systems. Where P^* and Q^* represent the active power and the reactive power to be delivered, respectively. The regulation of the output voltage is no longer a goal, so the control scheme only includes the primary current control. The grid-feeding must be fully synchronized with the AC voltage at the contact point, for precise control of the active and reactive power exchanged with the grid. Therefore, we have to use phase closed loop (PLL). Grid-feeding power converters cannot operate in island mode if there is no grid-forming or grid supporting power converter, or a local synchronous generator, setting the voltage amplitude and frequency of the AC micro grid[3]. Fig 6 shows Basic control scheme of a grid-feeding voltage source inverter.

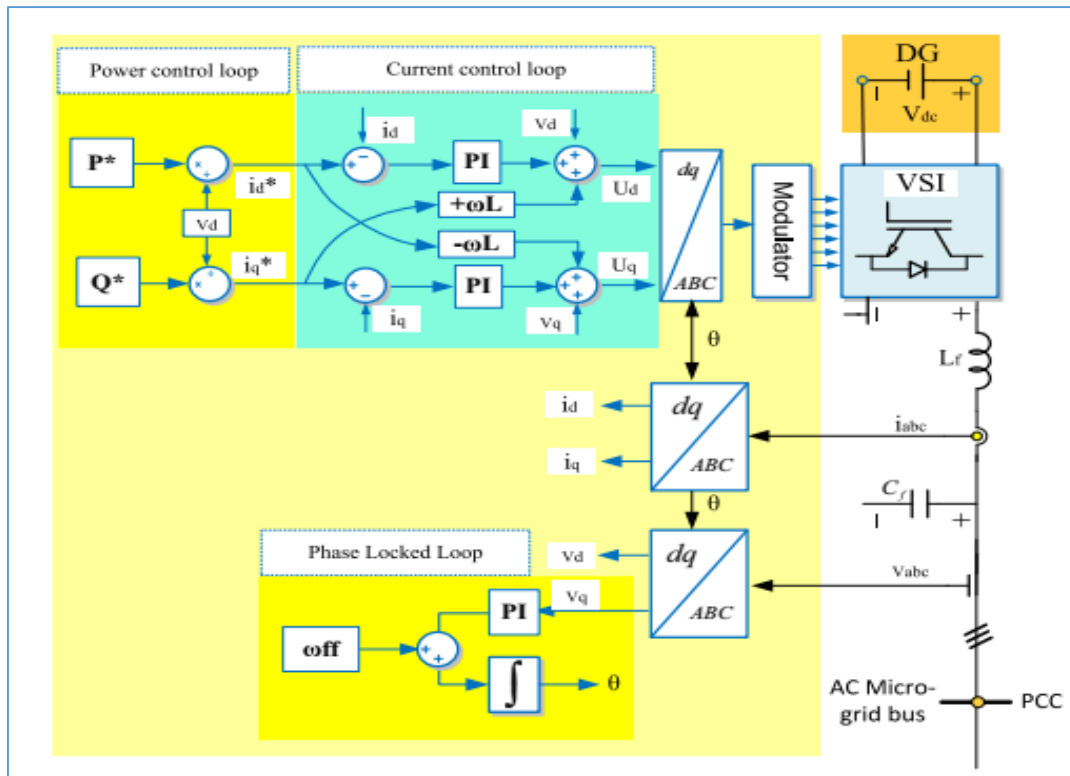

Fig n°6: Basic control scheme of a grid-feeding voltage source inverter [3]

1.6.3. Control of grid-supporting power converters:

Grid-supporting power converters are designed to control the AC grid voltage amplitude (reactive power) and frequency (active power) quality of either a stand-alone or interconnected grid allowing power sharing for to power balancing.

The Grid supporting power converter operating as a voltage source allows regulating the amplitude and the frequency of the grid voltage in both grid-connected and island modes.

The voltage amplitude and frequency are no longer fixed but obtained as a result of the droop equations as a function of active and reactive power components. In such a control scheme, active and reactive power P and Q delivered by the power converter are calculated by multiplying direct i_d and quadrature i_q current components by the direct U_d voltage grid component. [3]. Fig 7 shows Basic control scheme of a Grid-supporting power converter operating as a voltage source

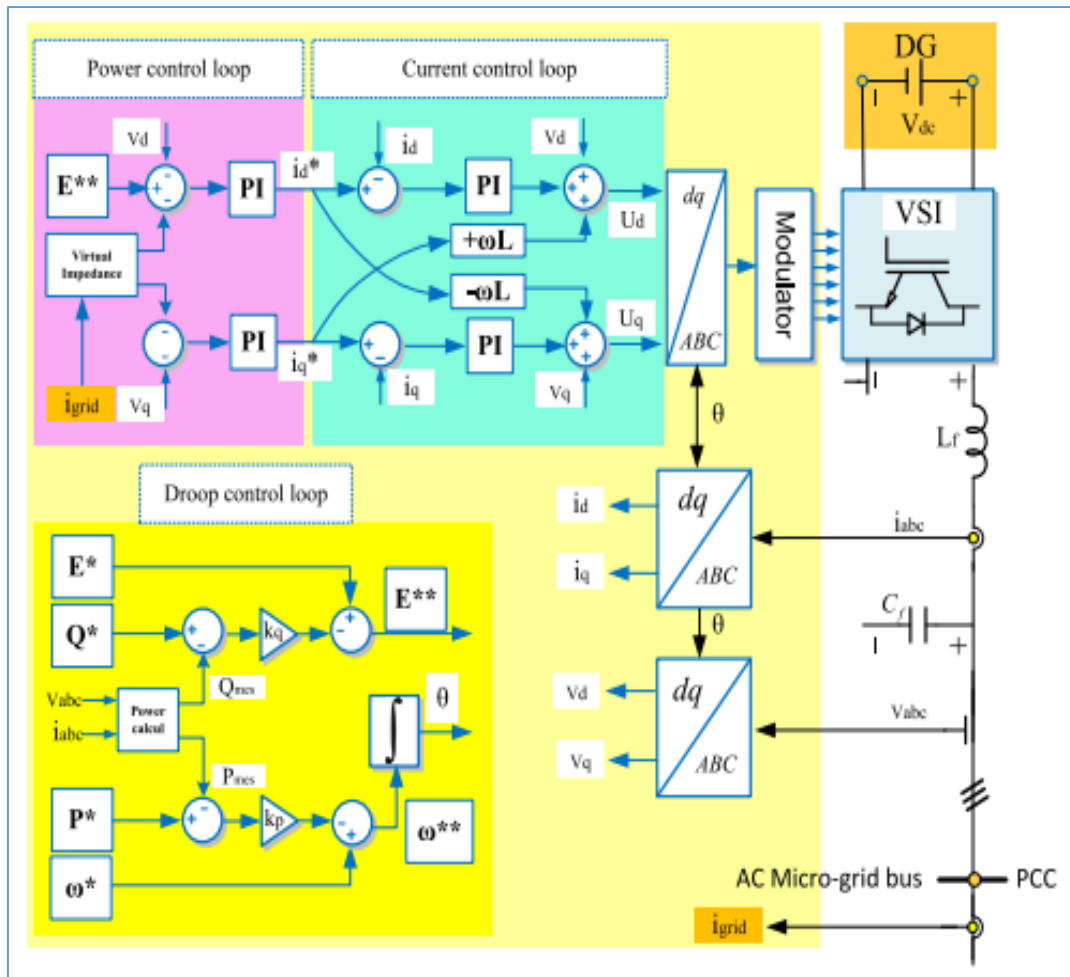

Fig n°7: Basic control scheme of a Grid-supporting power converter operating as a voltage source [3]

1.7. Grid Filter:

In order to improve the power quality, we need to reduce the harmonic distortion with increase output current and voltage, that lead us to looking for designing a filter to attenuate the wide range of harmonics and the switching frequency noise of the three-phase current generated. Noise and high frequency harmonics can be attenuated by passive filters.

The passive filter in a network-connected voltage source (VSI) inverter requires a small filter size and harmonic limits defined by the IEEE-519 standard, ideally, the main function of these filters is to attenuate the high-frequency switching components produced during pulse width modulation. Diverse types of passive filters have been used such as L-filter, LC-filter and LCL-filter as presented in Fig. 8. In designing a low pass filter the weight, cost, power losses and volume needs to understand before the use. Recently, higher order filters are used like

LCL filter because it has great advantages over conventional L filter, LCL filter has many advantages over L filter and LC filter, such as low THD of the three-phase current output filter, low cutoff frequency, power density and low cost of components, it also provides an attenuation of 60 dB / Dec.

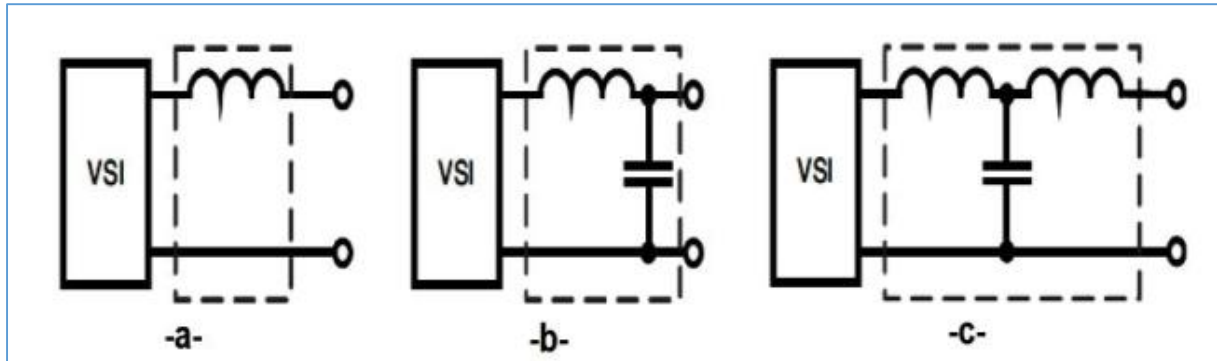

Fig n°8: Basic Filter Topologies: -a-Filter L, -b-Filter LC, -c-Filter LCL.[5]

In our study, the LC-filter (Fig. 8b) is used due to its advantage for grid-forming inverter. this type of filter is second order filter and it has better damping behaviors than L-filter, this simple configuration is easy to design and it works mostly without problems.

The second order filter provides 12 dB per octave of attenuation after the cut-off frequency f_0 , it has no gain before f_0 , but it presents a peaking at the resonant frequency f_0 . Transfer function of the LC-filter is,

$$F(s) = \frac{1}{1 + s \times L_F + s^2 \times L_F \times C_F} \quad (7.1)$$

The special design of the filter is a compromise between capacitance and inductance value, high capacitance has positive effects on the quality of the voltage. On the other hand, a higher inductance value is required to achieve the required filter cutoff frequency. [5].

1.8.Grid Synchronization Method:

Grid synchronization is a very important task in grid-connected applications, stable and accurate current control of the system to the grid being the goal. Grid synchronization is accountable for phase angle, amplitude, and frequency of the grid voltage. Various grid synchronization methods have been proposed in the literature such as zero crossing method(ZCM), phase locked loop (PLL) and virtual flux (VF) [4].

1.8.1. Phase Locked Loop (PLL)

Grid synchronization is an essential control function in a grid-connected converter. The grid synchronization function extracts the phase angle of the grid voltage which is needed for reference frame transformations, synchronized switching of the power semiconductor devices and correct calculation and control of the active and reactive power flow. There are many grid synchronization methods, the most common of which are based on the phase-locked loop (PLL). [4]

The PLL contains three parts: a phase detector, loop filter, and voltage controlled oscillator. Fig 9 shows PLL Basic Scheme.

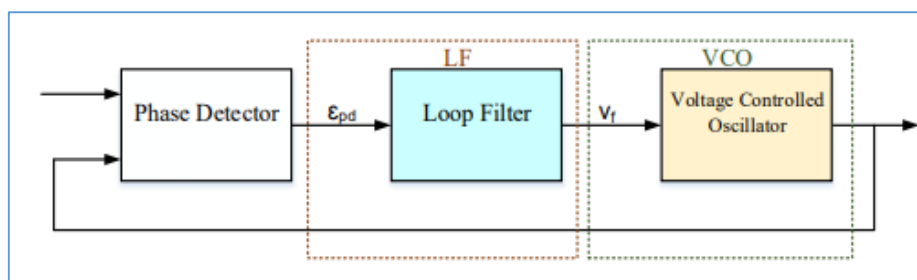

Fig n°9: PLL Scheme [4]

PLL combining VCO and phase comparator so connected that oscillator maintain constant phase angle relative to reference signal

The oscillator in the feedback loop has been used to control the output signal from the phase detector. Frequency is the time derivative of the phase. Keeping both the input and output stages in the locking stage involves maintaining the input and output frequencies in the locking stage. Therefore, it can follow the input frequency or it can generate doubling frequency of the input frequency. [4]

1.9. Power Quality (Abnormal Situations):

A three-phase inverter connected to the grid is usually a factor in the injection and absorption of energy into the grid. An example is drives that focus on absorbing active power extracted from the grid to achieve optimum performance of an electric motor. Under normal grid conditions, a three-phase inverter injects all the active power into the grid. However, the widespread use of electronic and nonlinear charges has had negative effects on power quality, which is an important issue. Therefore, the term power quality can be used to

refer to any problem that arises from an unusual situation in the system. Power quality is adversely affected when the system is exposed to abnormal conditions in voltage, current and frequency when disturbances occur in the general electrical network. [4]

I.9.1. Voltage Sags:

One of the main types of abnormal conditions in the system is voltage Sags (also called voltage drop). The voltage drop occurs like any voltage disturbance in the network caused by a failure in the network. According to IEEE 1159/95, voltage drop is defined as a drop in one or more phases of a voltage waveform in a common coupling (PCC). The percent voltage drops to 10% to 90% of the nominal value over a period of 0.5 cycles to 1 minute [4].

II.9.2. Voltage Swell:

A voltage swell is an increase in one or more phases of the voltage waveform in (r.m.s) for radiation ranging from 0.5 cycles to 1 minute according to the IEEE 1159/95 standard. However, voltage swells are not as familiar as voltage sags and are a less frequent type of abnormal grid conditions. Voltage swells can be caused many conditions such as a single line to ground faults or when switching in large capacitor banks, or when large loads are switched off [4].

I.10. Chapter Summary:

This chapter has presented the main review of the Photovoltaic systems and micro grids, grid synchronization method, furthermore a comparison between grid filter types. Moreover, a three-phase grid-forming inverter have been discussed, have been in order to get deep understand of the system. besides discussing different type of outer control loops for DPGS such as Control of grid-forming, grid-feeding, grid-supporting power converters. And finally a special attention has been paid for the Phase Locked Loop (PLL) with an explanation and reasons for its use.

II.1. Introduction:

Grid-forming DGs are responsible for generating the voltage of the grid. They are, in practice, supplied by a stable source such as batteries, fuel cell modules, and micro-turbines. The amplitude and frequency of the grid are determined and controlled by the grid-forming DGs, and hence, they form the reference for the other DGs. A general control block diagram of a grid-forming converter of the amplitude and frequency of the output voltage (v_{abc}) are determined by a nominal amplitude E^* and nominal frequency ω^* . The three-phase balanced sinusoidal AC voltage U_{abc} is generated by two cascaded synchronous controllers in the d-q reference frame. The phase angle of the AC voltage is formed by integrating the nominal frequency.

The Parallel operation of the grid-forming DGs requires a precise synchronization system at the start-up point. In the islanded mode of operation, the synchronization system should oscillate at the nominal frequency ω^* to form the output voltage. During the connection to the grid, grid-forming converters need to be synchronized with the grid. Therefore, the synchronization system should slowly change the frequency (ω^*) and the phase angle (θ) to synchronize with the grid. During the islanding, the synchronization system needs to detect the islanding condition, and accurately provide the synchronization signals to the DG in order to form the voltage of the local grid [3]and [6].

II.2. Pulse width modulation (PWM):

the ultimate goal of the PWM is to generate gating pulses of the switches for the inverter to produce an output voltage with the desired fundamental amplitude and frequency. There are different kinds of PWM switching techniques, such as sinusoidal PWM, space vector, Modulation (SVM), PWM

hysteresis band and PWM removal of the third harmonic. Among these the most common is carrier-based sinusoidal PWMs [7].

For such PWM inverters, the following control is possible:

- ✓ Linear control of the fundamental output voltage
- ✓ Control of frequency of the fundamental output voltage
- ✓ Control of harmonics included in the output voltage

II.2.1. Sine pulse width modulation (SPWM)

Sinusoidal PWM is a typical PWM technique. With this PWM technology, the sinusoidal alternating voltage reference V_{ref} is compared with the triangular high-frequency reference. Carrier wave v_c in real time to determine the switching states of each pole of the inverter. After the comparison, the switching states can be determined for each pole based on the following rule. Fig 10 shows a Sinusoidal PWM technique explain:

- $v_{ref} >$ Triangular carrier v_c : upper switch is turned on (pole voltage = $V_{dc}/2$)
- $v_{ref} <$ Triangular carrier v_c : lower switch is turned on (pole voltage = $-V_{dc}/2$)

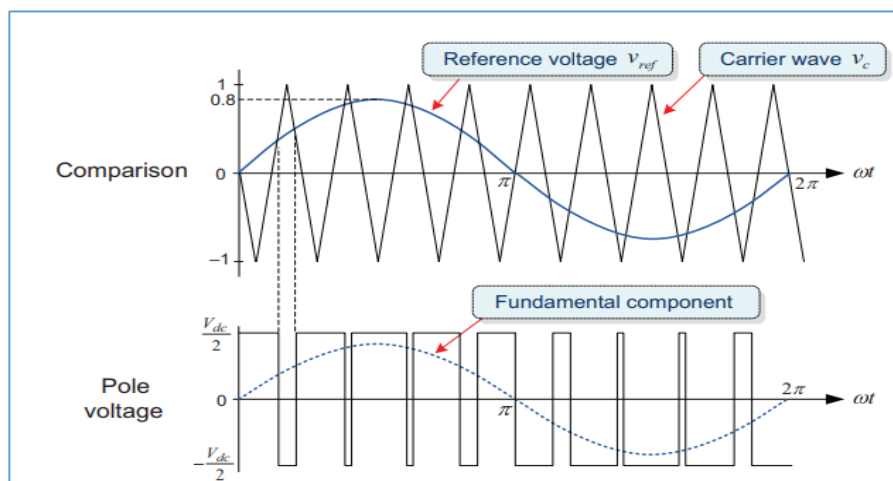

Fig n°10: Sinusoidal PWM technique [8]

The operating principle of PWM is that it is limited by the modulation index (m_i) which is the ratio of the amplitude of the reference signal to the carrier signal: $M_i = V_r/V_c$ Where V_r is the reference amplitude and V_c is the carrier amplitude. Fig 11 shows a Voltage modulation range for SPWM.

The output voltage varies linearly with the reference voltage v_{ref} for a constant DC-link voltage as:

$$V_{o1} = V_{ref} \sin \omega t = \frac{V_{dc}}{2} * \sin \omega t \quad (2.1)$$

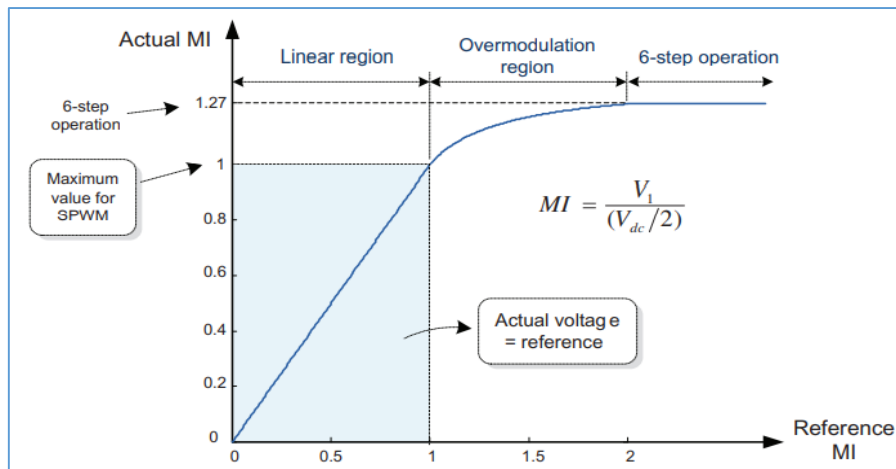

Fig n°11: Voltage modulation range for SPWM. [8]

since $v_{ref} \leq V_{dc}/2$, so $0 < MI < 1$ we call it linear regain where inverter can generate an output voltage linearly proportional to the reference voltage when $MI > 1$ is called over modulation region, where the linearity of the modulation is lost which make the system instable

the maximum modulation index attainable by the SPWM technique corresponds to 78.5% of the maximum output voltage $m_{imax} = \frac{\sqrt{3}}{2} V_{dc}$ For three phase sinusoidal wave (v_a, v_b, v_c) which are the fundamental signals of the three-phase symmetrical sinusoidal signals that are shifted by 120 deg .[8]

$$v_a(t) = m_i V_{dc} \sin(\omega t) \quad (2.2)$$

$$v_b(t) = m_i V_{dc} \sin\left(\omega t - \frac{2\pi}{3}\right) \quad (2.3)$$

$$v_c(t) = m_i V_{dc} \sin\left(\omega t + \frac{2\pi}{3}\right) \quad (2.4)$$

Fig 12 shows a SPWM technique for a three-phase inverter.

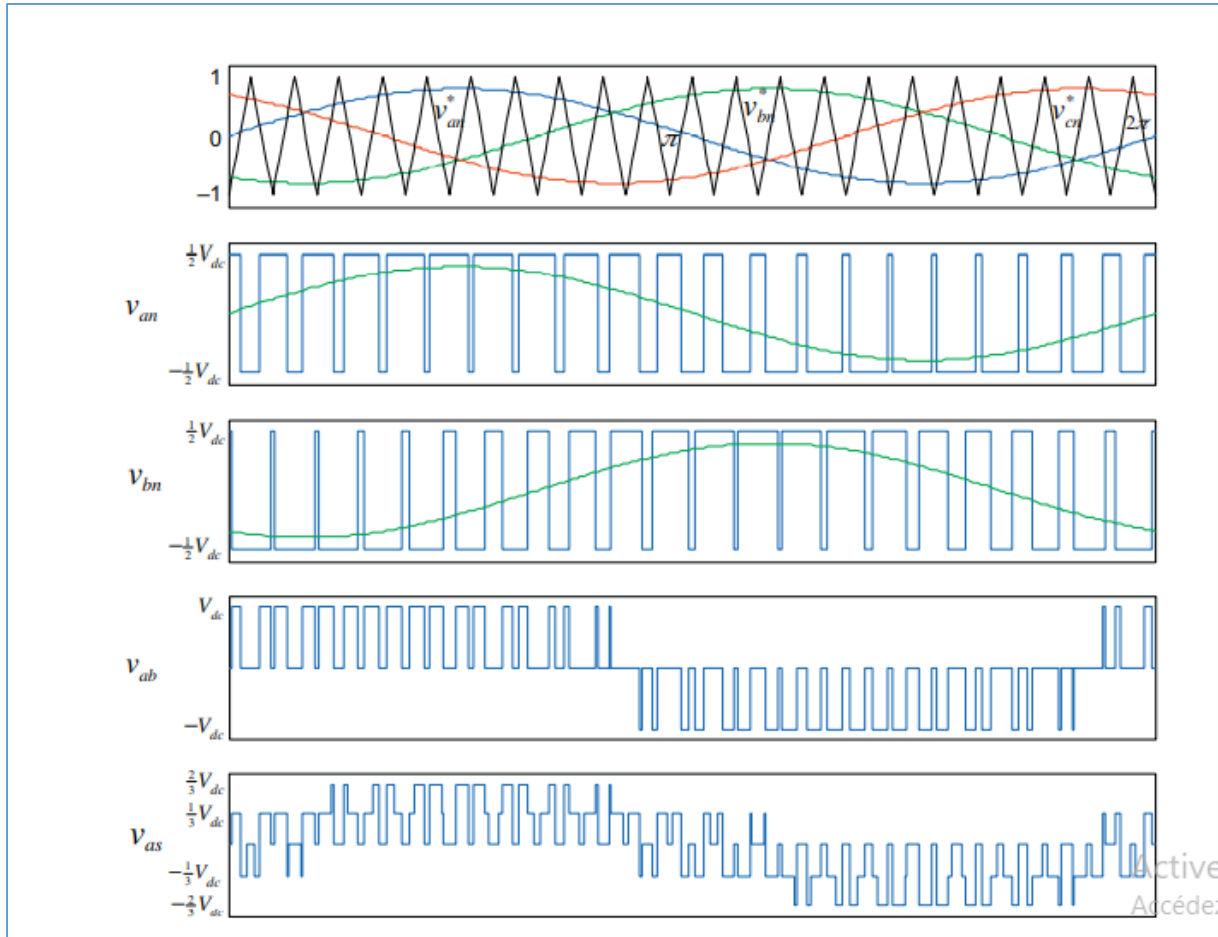

Fig n°12: SPWM technique for a three-phase inverter. [8]

We can see that the switching frequency of an inverter is equal to that of a carrier wave which is an advantage to have constant switching frequency [8].

II.2.2. Harmonic analyses:

we will investigate the harmonic components of the pole voltage v_p in order to see which harmonics are contained in the output voltage generated by the SPWM technique, as we know that pole voltage has harmonic in the carrier frequency (f_c) and frequencies of its integer multiples (M), and the sidebands (N) of all these frequencies [9]. Fig 13 shows a frequency spectrum of the pole voltage for the SPWM.

$$V_{oh} = V_h \sin[2\pi(Mf_c + Nf_o)t + \phi_h] \quad (2.5)$$

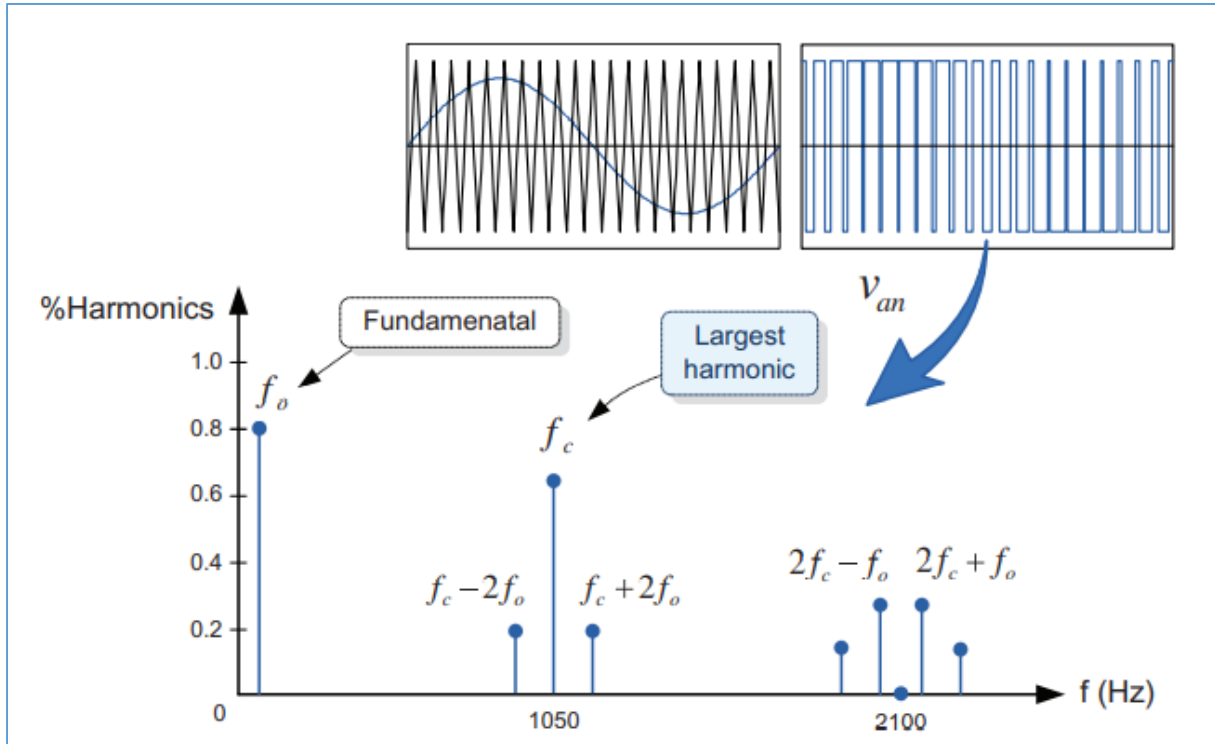

Fig n°13: Frequency spectrum of the pole voltage for the SPWM [8]

As we see in this example that the frequency spectrum for the pole voltage of $f_o = 50$ Hz and $m_f = 21$ is too large which equal to 1050 Hz $(= 21 * 50$ Hz) And modulation frequency $m_f = f_c/f_o$ which is the ration between carrier and fundamental frequency. Since the line-to-line voltage is the difference between the two pole voltages, they do not have any harmonic at multiples of three, which exist in the pole voltages because the harmonics at multiples of three included in the pole voltages will have no phase difference with each other [8]. Fig 14 shows a frequency spectrum of the line-to-line voltage for the SPWM .

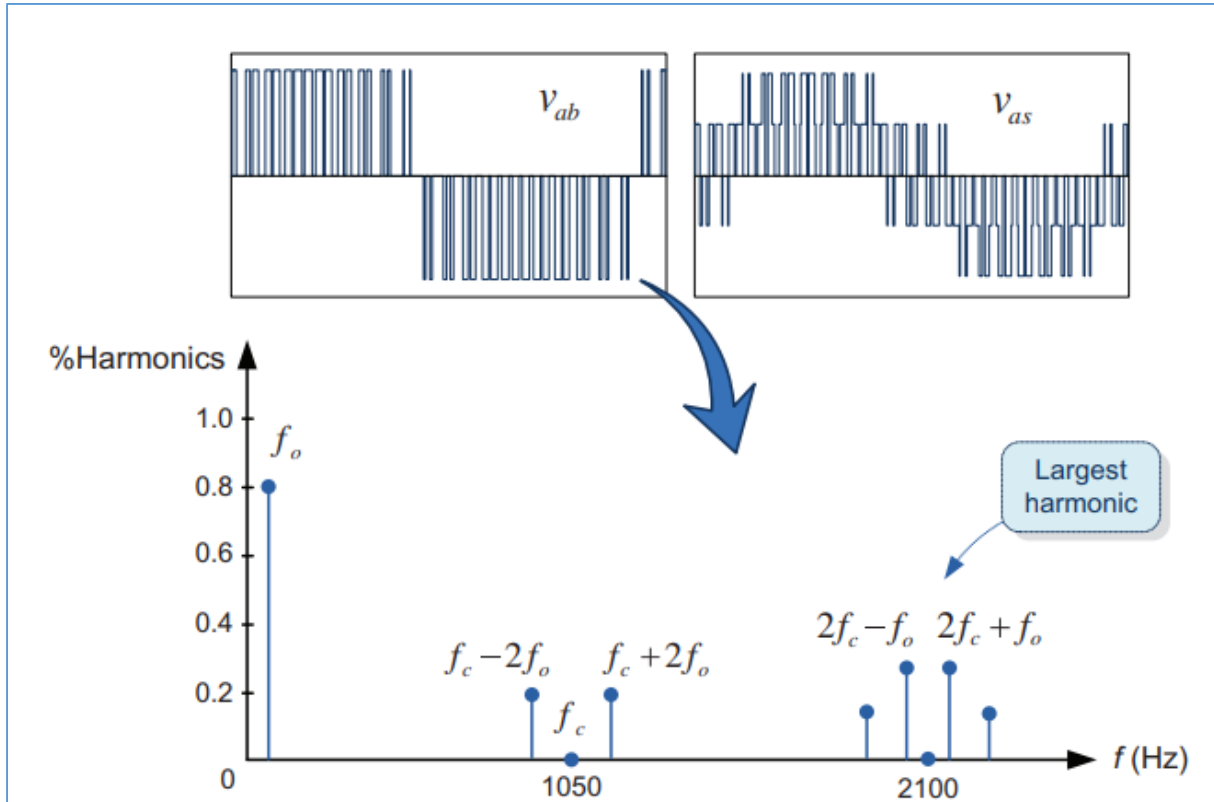

Fig n°14: Frequency spectrum of the line-to-line voltage for the SPWM (MI 5 0.8, mf 5 21). [8]

However, one of the shortcomings of SPWM, total harmonic distortion (THD) is higher than space vector modulation (SVM).

II.3. Overview of inner control loops:

Depending on the electrical grid conditions at the PCC. The control of a VSI is designed on the DPGS application, there are different control methods can be used, the benefit from those is to achieve satisfactory performance in terms steady state error requirements for utility connected converters and improve the disturbance rejection by rejecting utility voltage harmonics. The control techniques vary from the very simple methods to complex analytical approaches [3]

II.3.1. Basics of current control:

Current control applies as inner loop section on the control of inverter. The main task of inverter's CR-PWM control system is to force the current vector to follow the reference path. Basics requirements are as follows [10]:

Chapter II: Grid-Forming System Modeling and Control

- Significantly no phase and amplitude errors (perfect tracking) output frequency range.
- quick response to high system dynamics, to ensure a limited or fixed switching frequency, Safe operation of electrical semiconductor switches
- good dc-link voltage uses

II.3.2. Hysteresis Current Control:

This method has of three independent hysteresis controllers; one for each the VSC's phase leg. The measured current is compared with the desired reference current, a hysteresis comparator that is feeding by the error use to create switching signal in order to limit the error in fixed hysteresis band. No separate modulator is required with hysteresis control as this type of current control directly generates the switching signals [12]. Fig 15 shows a Principle of hysteresis control. Also Fig 16 shows The block diagram of hysteresis current control

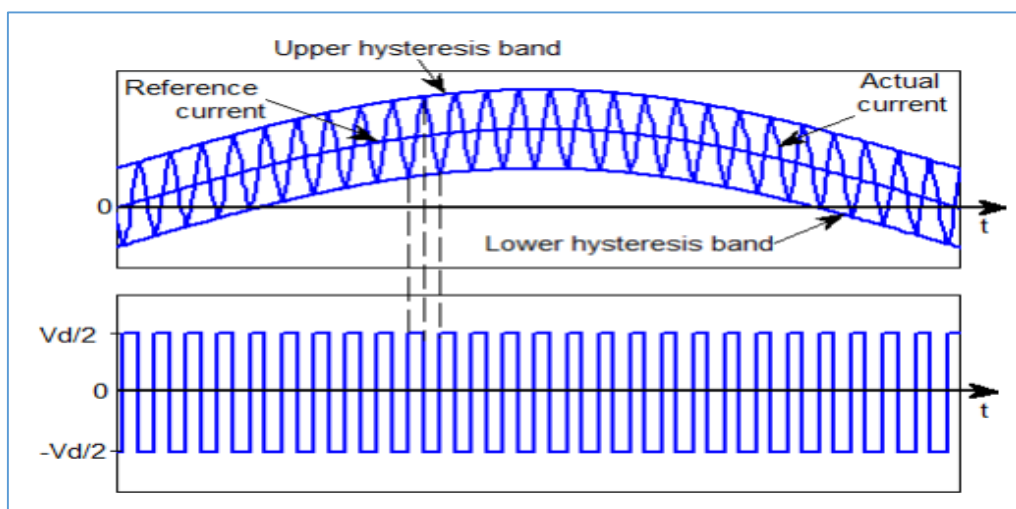

Fig n°15: Principle of hysteresis control: current (upper) and converter output voltage(lower) [12]

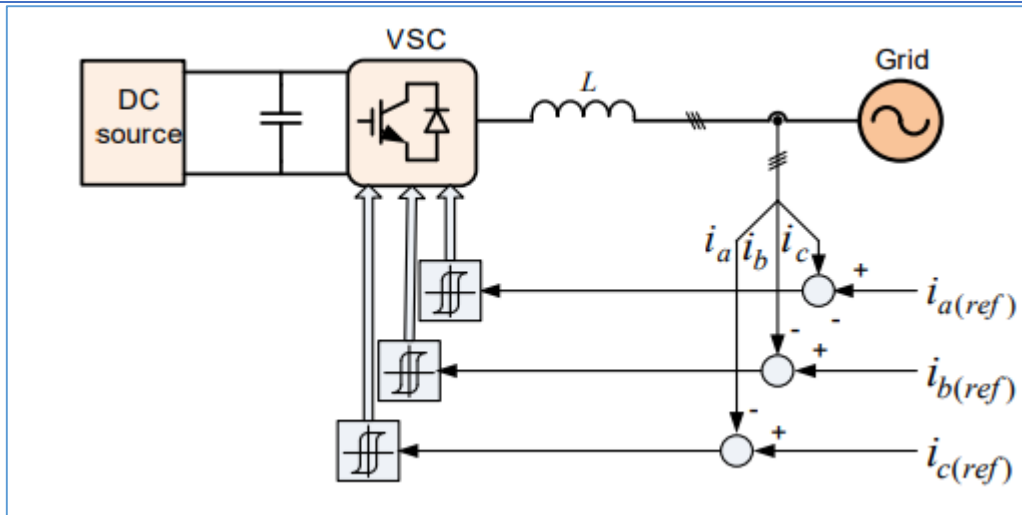

Fig n°16: The block diagram of hysteresis current control [12]

We note that It is easy to implement, robust to load changes and has a very fast dynamic response. However, the output voltage has a variable switching frequency, which makes it difficult to design a filter if used to control a grid-connected VSC. A high switching frequency is required for the controller to compensate for its inherent drawbacks [7]. A further drawback is that it does not have the possibility of controlling the active power and the reactive power independently which other methods typically do. Improvements to the basic hysteresis controller, by operating with a constant switching frequency [12]

II.3.3. Classical pi controller

classical PID control is the most employed technique for many different applications, this technique is simple which is based on the complex-domain approach, that is uses in linear time invariant, single-input single-output (SISO) where both i_d and i_q are controlled using independent PI controller to track reference values $i_{ref d}$ and $i_{ref q}$, respectively. Output of PI controller, together with the terminal voltage in dq and cross drop voltage in the inductor filter L, generates the voltage references $v_{ref d-pwm}$ and $v_{ref q-pwm}$. Those voltage references drive the Pulse Width Modulation (PWM) to produce the corresponding command for the switches of the grid-connected inverter. [13]. Fig 17 shows the block diagram of dq cross-decoupling current control scheme.

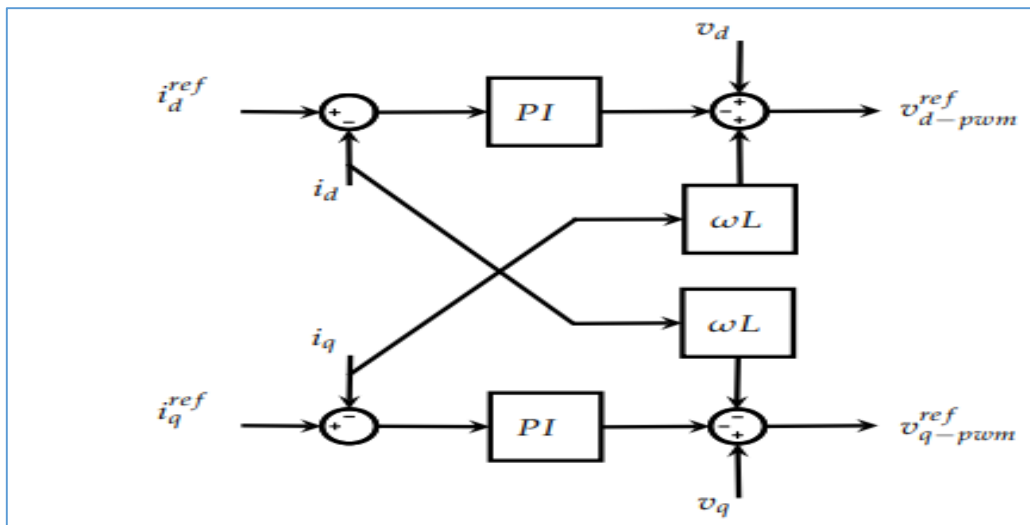

Fig n°17: the block diagram of dq cross-decoupling current control scheme [13]

Actually for synchronous frame where we transform abc to dq frame as we make the ac to Dc quantity where the pi controller has good performance in the regulation of dc variables. Fig 18 shows a Modeling of pi controller.

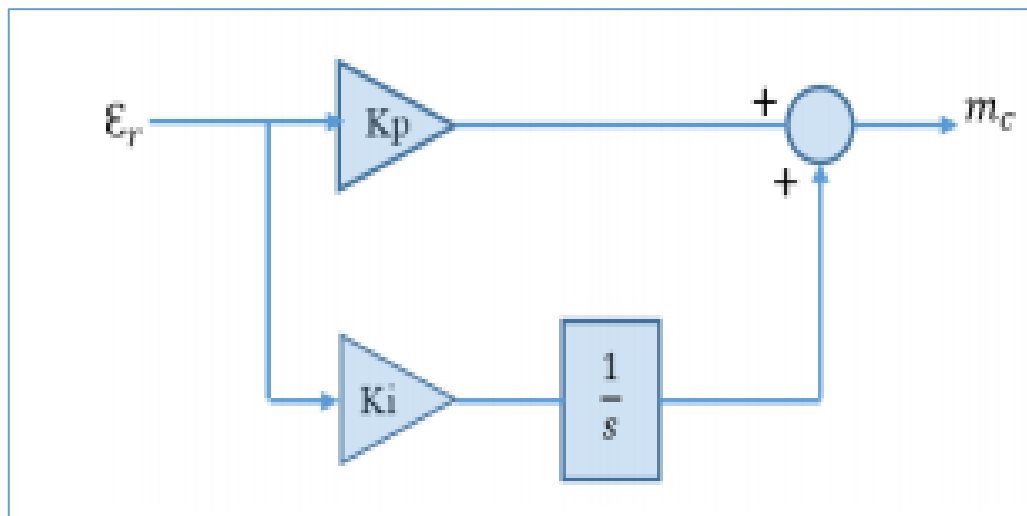

Fig n°18: Modeling of pi controller [2]

The block diagram of pi controller which consists of a proportional gain, KP and integral gain, Ki, while (m_c) and (ϵ_r) are the control and error signals.

The transfer function of the system is given by la place transmission

$$G_{pi}(s) = \frac{m_c}{\epsilon_r} = \frac{k_i}{s} + k_p$$

This method misses proper performance for unbalanced systems. [13]

II.4. Proposed Experimental Module (Grid-Forming Mode Control):

We use Grid-Forming Mode Control in order to regulate voltage and frequency references provided to the inner control loops. Primary control should have a quick response to any variation between generation and consumption so that it leads to a balance situation.

The power inverter connected in parallel to the grid is controlled to exchange the power between the grid and the DPGS, this power is more or less proportional to the desired power, and the power inverter

Fig 19 shows a Grid-Forming Mode Control. The operation of the grid-forming converters is based on the voltage control mode on the islanding condition. This means that at least one of the converters in the system should be operated in this mode to provide voltage reference to another DG's. [3]

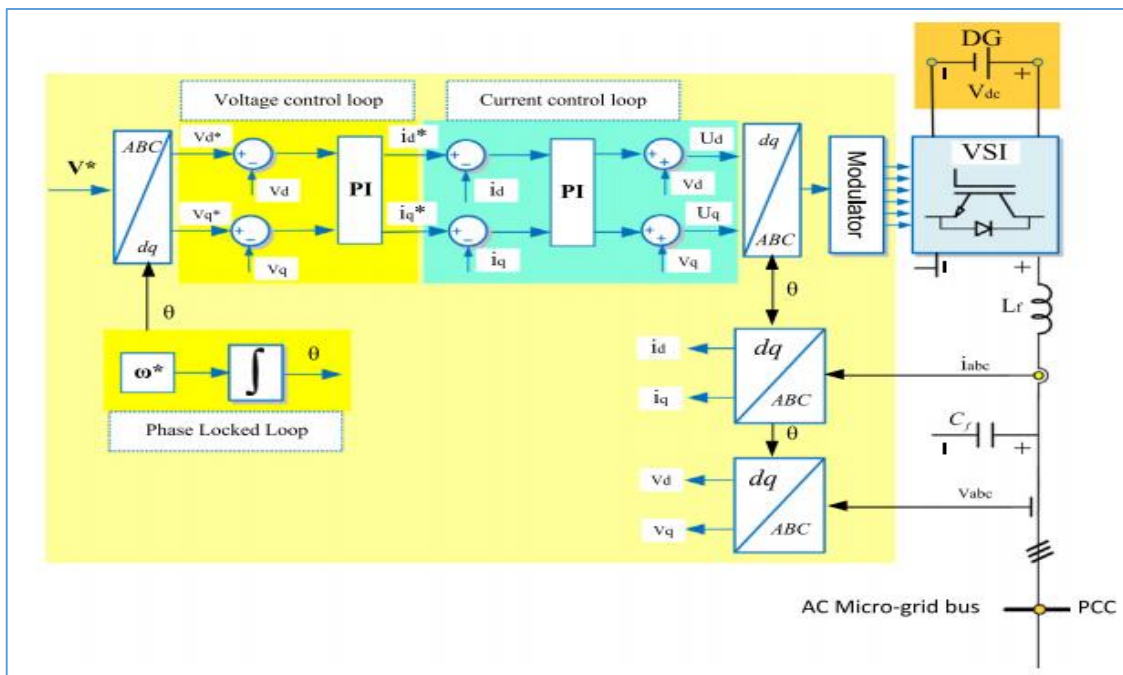

Fig n°19: Grid-Forming Mode Control [3]

As we show in the fig. 19 that It consists of double-loop control inner of current and outer of voltage control section, voltage reference section, and measurement section. Voltage reference can be either internal or external three-phase signal through dq transformation and PLL. This scheme generates three-phase voltage v , which follows the voltage reference. [11]

To construct the grid-forming mode control of grid-connected inverter, several blocks should be used:

II.4.1. Synchrones frame d-q Transformation :

We called it Park transformation, is a space vector transformation of three-phase time-domain signals from a stationary phase coordinate system (abc) to a rotating coordinate system (dq). The dq transform reduces three-phase AC quantities (V_a , V_b , and V_c) into two DC quantities (V_d and V_q). The DC quantities provide easier control or filtering process. Another advantage is that active and reactive power can be controlled independently by using dq quantities.

Power invariant formulation of dq transformation of any variable, V , of three-phase signals into dq quantities can be expressed by Equation

$$\begin{bmatrix} V_d \\ V_q \end{bmatrix} = \frac{\sqrt{3}}{2} \begin{bmatrix} \cos(\theta) & \cos(\theta - 2\pi/3) & \cos(\theta + 2\pi/3) \\ -\sin(\theta) & -\sin(\theta - \frac{2\pi}{3}) & -\sin(\theta + \frac{2\pi}{3}) \end{bmatrix} \begin{bmatrix} V_a \\ V_b \\ V_c \end{bmatrix}$$

Where θ is the is phase displacement between the rotating and fixed coordinate system at each time t [13]

II.4.2. Phase-Locked Loop (PLL) :

The common method to realize PLL on three-phase system is by using synchronous frame PLL. Figure 3 shows the block diagram of synchronous frame PLL. Instantaneous phase angle θ is detected by synchronizing the reference frame with the vector of three-phase voltage (v_a , v_b , and v_c). Fig 20 shows a Block diagram of PLL .To be locked to the phase angle of utility voltage vector, the Proportional–Integral (PI) controller drives v_q to be zero, as given by the reference v_q^* , which gives the angular speed quantities. Phase angle θ is simply obtained by integrating the angular speed. [13]

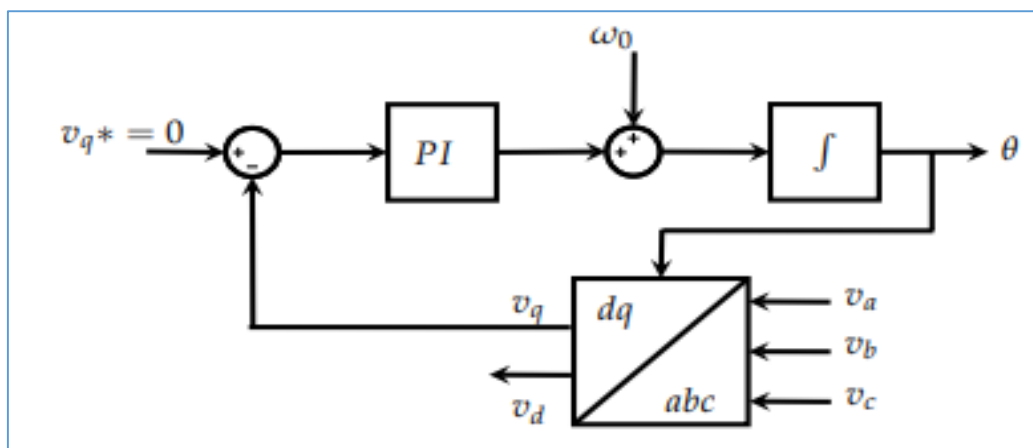

Fig n°20: Block diagram of PLL [13]

II.4.3. Voltage Control

Voltage control acts as outer loop in the grid-forming mode of grid-connected inverter. where the current acts as inner loop as we the figure below shows us that. Fig 21 shows a Voltage Control outer loop scheme:

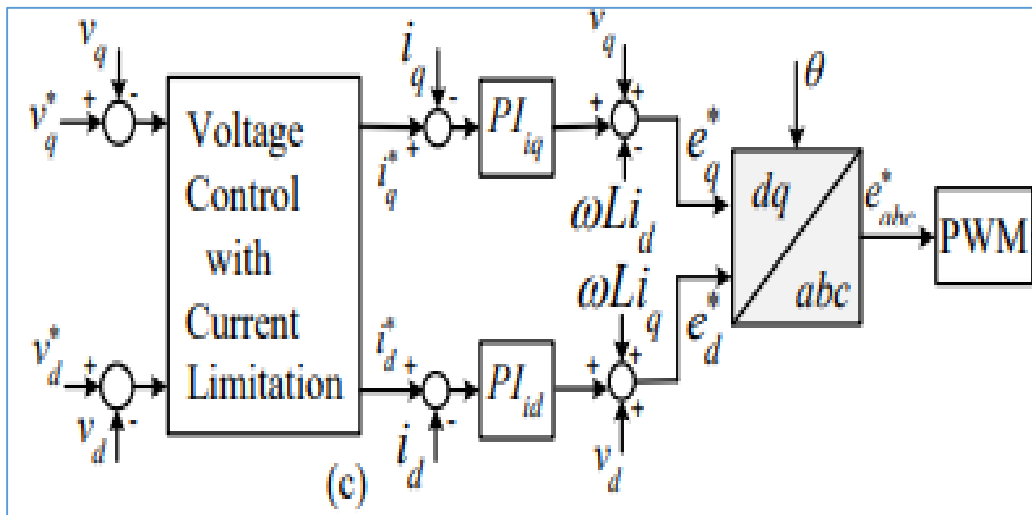

Fig n°21: Voltage Control outer loop scheme. [13]

Fig 22 shows a (a,b) control of voltage in dq frame by using two different PI controllers. For the voltage control block shows independent control of voltage in dq frame by using two different PI controllers. PI controller tracks the error between the reference voltage, $v_{ref\ d}$ (or $v_{ref\ q}$), and actual output voltage, v_d (or v_q). It generates corresponding signal for the reference current controller i_d^* i_q^* , which in turn determines the required current of the grid-connected inverter that compare to current amusement through inductor i_d i_q . [13]

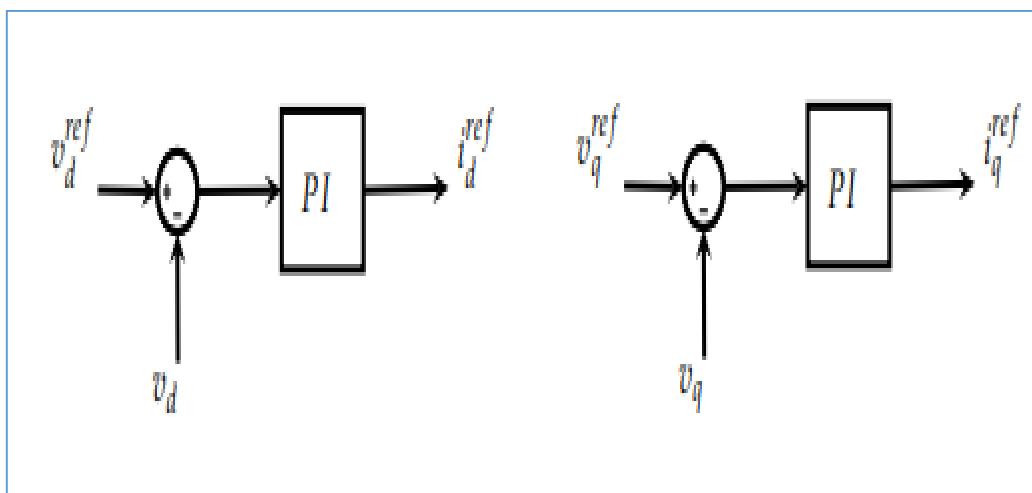

Fig n°22: a,b control of voltage in dq frame by using two different PI controllers. [13]

the reference voltage can be obtained from either signal generator or voltage sensor measurement on the capacitor through abc to dq transformation. Signal generator receives input of frequency, f , and magnitude, V , to generate three-phase signal reference. This block is mainly used when the grid-connected inverter is on stand-alone operation supplying power to the local loads, thus it should provide stable output voltage. [13]. Fig 23 shows a stand-alone grid connected inverter.

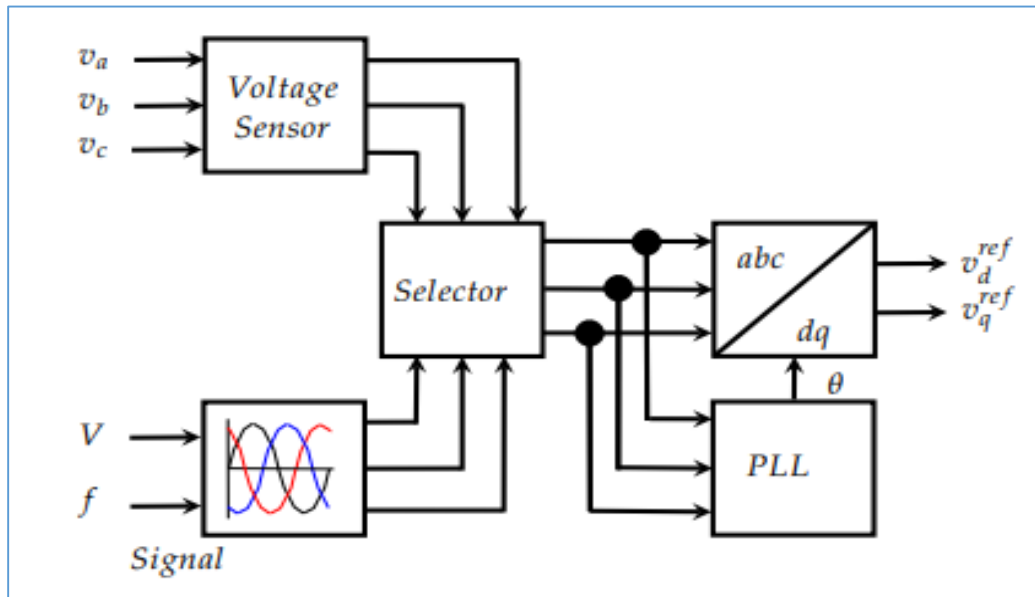

Fig n°23: stand-alone grid connected inverter [13]

The other method to generate voltage reference is by using three-phase measurement on voltage sensor, and then transforming into the corresponding dq voltage reference. This method is suitable when the grid-connected inverter is synchronized with the main grid, for which the synchronized set of three-phase output needs to be produced by grid-connected inverter. Three-phase voltage of the main grid on the point of synchronization is measured through voltage sensor, and then the phase angle is detected by using PLL to obtain proper dq transformation angle. Voltage control tracks this set of reference voltage, therefore it is expected that the output voltage of grid-connected inverter is synchronized with the main grid. [13]

II.4.4.PWM Generation

Voltage references for PWM generated by current control, $v_{ref\ d-pwm}$ and $v_{ref\ q-pwm}$, are still in dq frame. However, the sinusoidal PWM method needs three modulating signal displaced 120° as its input values. Therefore, the

voltage references v_{d-pwm}^{ref} and v_{q-pwm}^{ref} should be transformed back to abc reference frame by using inverse Park transformation. Fig 24 shows a PWM generation scheme using dq transformation.

To ensure that the output of grid-connected inverter remains synchronized with the desired voltage, the phase angle θ obtained from PLL is used for the inverse dq transformation. The results are three controlled reference signals, v_{c1} , v_{c2} , and v_{c3} , for the PWM block. the schematic of this PWM generation scheme.

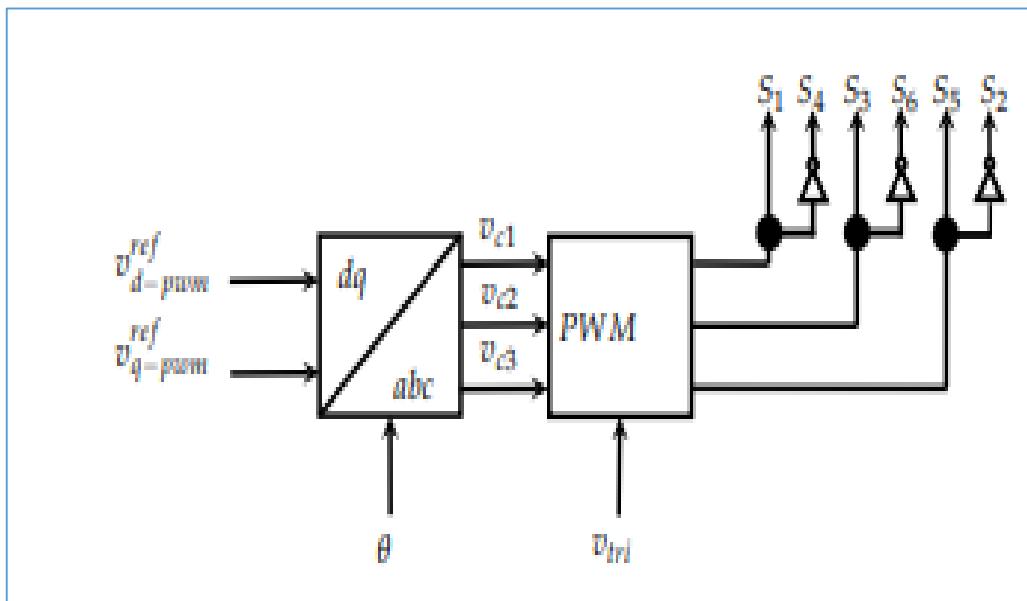

Fig 24: PWM generation scheme using dq transformation [13].

Those signals are references for our PWM that we use SPWM so the reference signals v_{c1} , v_{c2} , v_{c3} compared with the triangular high-frequency reference carrier wave v_c in real time to determine the switching states of each pole of the inverter [13].

II.5. Chapter Summary:

This chapter introduces the working principle of a three-phase grid-connected inverter. The most common three-phase grid connected-inverter is a two-level inverter (VSI). This inverter consists of six switches with freewheeling diodes. The three-phase grid-connected inverter is used to interface the PV panels which generates DC voltage into appropriate AC voltage for the utility grid, the first step is a DC-DC converter which used in this application to boost the voltage to the higher desirable values and the second is a DC-AC inverter to converts the DC value to the three-phase AC values. In additions, the modelling of the pulse width modulation PWM was discussed. There are different types of PWM switching technique, such as sinusoidal PWM, hysteresis band PWM and third harmonic elimination PWM. Among them, SVM is found to be the most suitable method for grid-connected inverters. In addition, the design of the passive components of the grid filter was presented. Different filters were discussed and the LCL filters have been shown to improve the power quality of the current injected into the grid and provide better attenuation of harmonic currents, therefore leading to reduced filter sizes compared with lower order L and LC filters. In addition, we discuss different current and voltage controller and its advantage with comparison between them, finally we describe a grid forming that we use this Mode Control in order to regulates voltage and frequency references provided to the inner control loop and its control that it depend on voltage control in order to create PWM to the inverter, In the next chapter, we will implement a grid forming with SPWM and pi controller in both simulation and experimental.

III.1. Introduction:

In this chapter, simulation and experimental results for the three-phase grid-forming inverter are presented using PI and SPWM controllers. The first part looks at the inverter controlled using a SPWM controller. The second section looks at the inverter controlled using PI controller. Performance evaluation of the controllers based on harmonic distortion and dynamic response of the system is also demonstrated. The system is applied and modeled first in Matlab/Simulink tools version 2014a, taking into account the normal and abnormal grid operating conditions. The model comprises the three-phase inverter powered from PV array, with an LC filter connected to the utility grid. The three-phase grid current is transformed to reference frame and fed to the appropriate controller. The control techniques consist of an external voltage control loop and internal current control loop. This structure increases the performance of the control system. The control variable is used to generate the PWM signal (SPWM);

This chapter also describes the experimental hardware equipment for the three-phase grid forming inverter. It contains an overview of the hardware used. The system comprises the three-phase inverter powered from a DC source and an LC filter forming to the three-phase inverter. The three-phase grid current is transformed to the reference frame and fed to the appropriate controller. The current control structure is based on PI or hysteresis current control [4].

III.2. SIMULATION AND LABORATORY SETUP PARAMETERS:

<i>PARAMETERS</i>	<i>Value</i>
<i>V_{dc} Voltage</i>	<i>300V</i>
<i>Phase ac output voltage (peak)</i>	<i>157V</i>
<i>Output frequency</i>	<i>50Hz</i>
<i>Switching and sampling frequency</i>	<i>10KHz</i>
<i>Filter inductor</i>	<i>3mH and 0.5Ω</i>
<i>Filter capacitor</i>	<i>84μF</i>

Tableau n°3: SIMULATION AND LABORATORY SETUP PARAMETERS.

III.3. Proportional Integral (PI) Current Controller:

the parameters for inner and outer PI controllers are:

PI voltage controller:

$$K_{pv} = 0.01$$

$$K_{iv} = \frac{K_{pv}}{0.5 \times C_f}$$

PI current controller:

$$K_{pi} = 250$$

$$K_{ii} = \frac{K_{pi}}{0.5 \times C_f}$$

where K_{pv} , K_{iv} , K_{pi} , and K_{ii} are the proportional (P) and integral (I) gains of the PIVC and PICC.

It should be noted that PI voltage controller in an outer loop of a cascaded control structure, which controls the load voltages and generates the reference currents for the inner loop. In this work, the PI current controller is employed in an inner loop without any adaptation law owing to its easy implementation and fast dynamic response. [3]

III.4. Simulink model of the three-phase grid-forming inverter with hysteresis Controller:

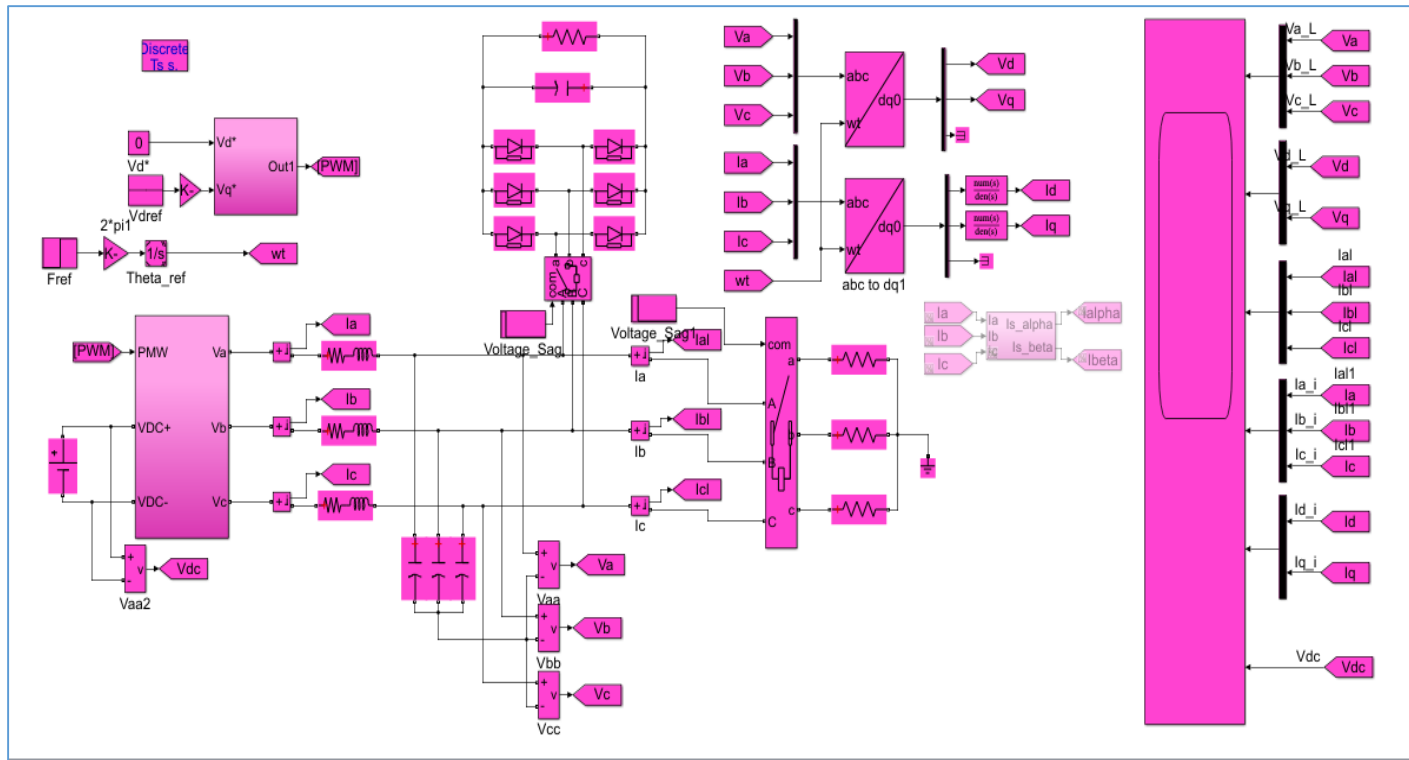

Fig n°25: Simulink model of the three-phase grid-forming inverter with hysteresis Controller.

III.5. Simulink model of the three-phase grid-forming inverter with PI Controller:

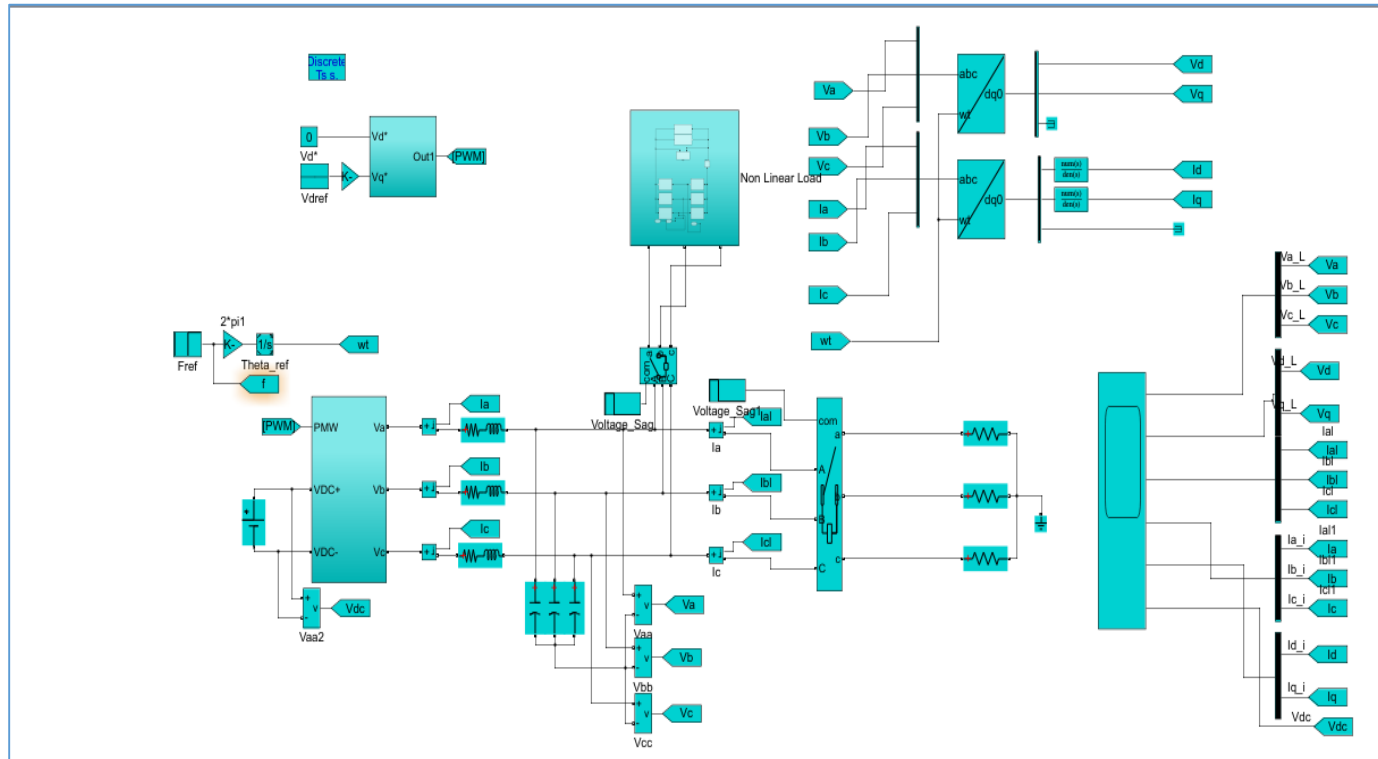

Fig n°26: Simulink model of the three-phase grid-forming inverter with PI Controller

III.6. Control of system based on Hysteresis technique:

III.6.1. Hysteresis controller under normal grid conditions:

In this control strategy the measured load currents are compared with the references using hysteresis comparators. Each comparator determines the switching state of the corresponding inverter leg such that the load currents are forced to remain within the hysteresis band. Based on the band, there are two types of current controllers, namely, fixed band and sinusoidal band hysteresis current controller. Fixed band current controller is considered in this study and gives the results below, on the figure 27 it is shown Synchronous Reference Frame Voltage v_{dq} on Hysteresis regulator which is gated by transform the the measured capacitor voltage to dq frame, this one compared to the reference in the outer loop (voltage loop) in order to give the reference current on dq frame (I_{dq}^*), the figure 28 represents the Synchronous Reference Frame current I_{dq} which is gated by transform the measured inductor current to the dq frame, this one compared to the reference in inner loop (current loop) on hysteresis regulator In order to give the reference voltage of pwm, The two figures show us accepted performance on normal condition with fast response [14].

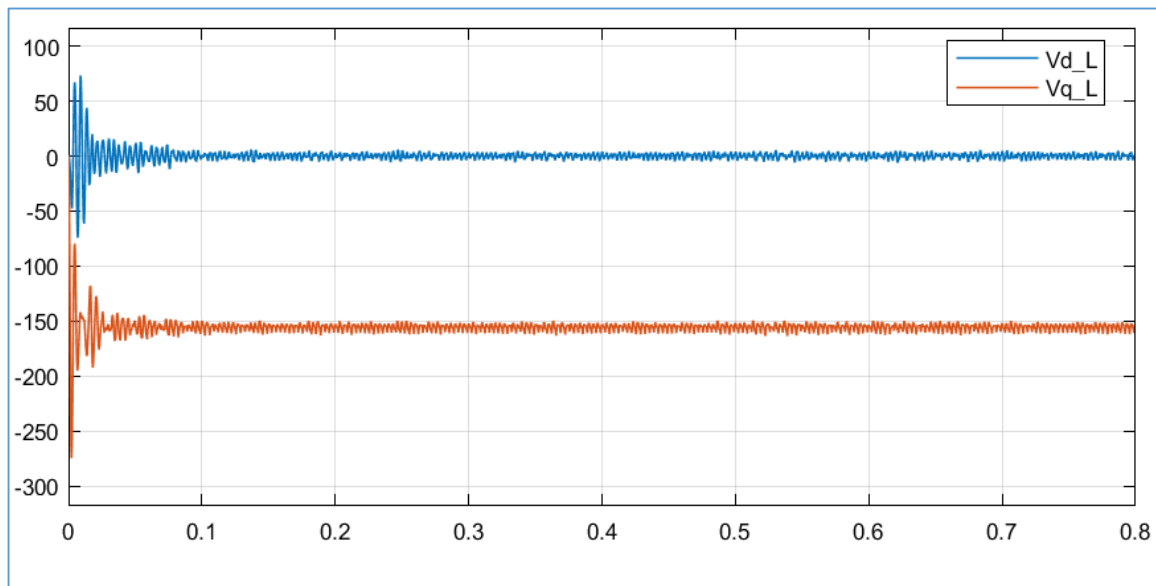

Fig n°27: Synchronous Reference Frame Voltage v_{dq} (Hysteresis)

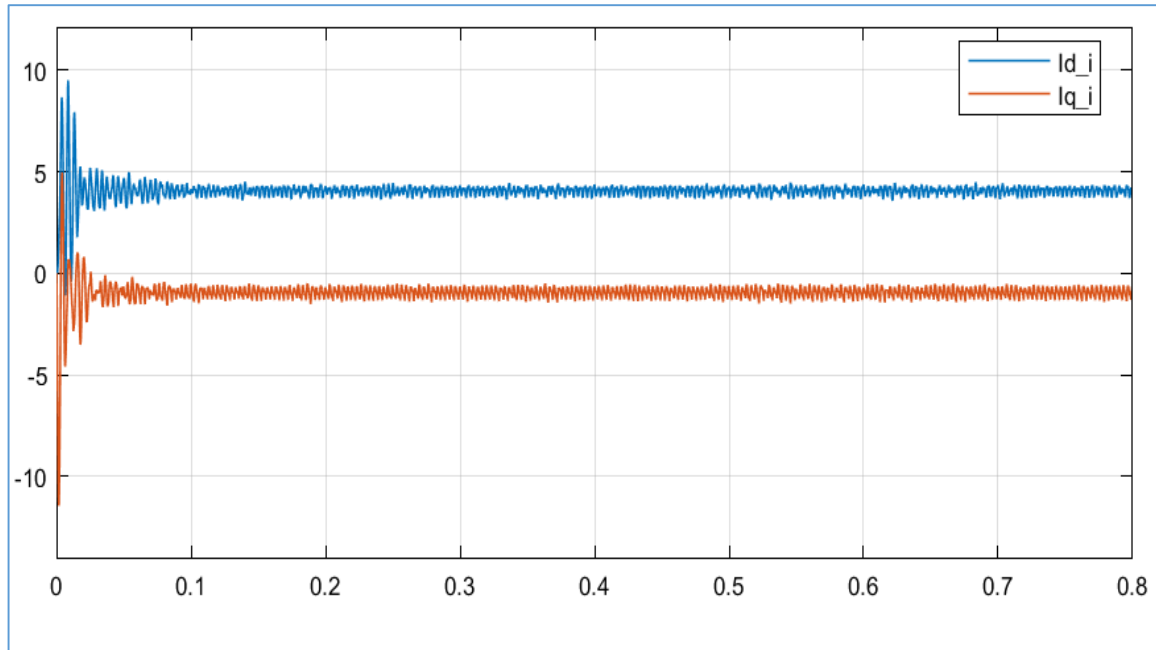

Fig n°28: Synchronous Reference Frame Current I_{dq} (Hysteresis).

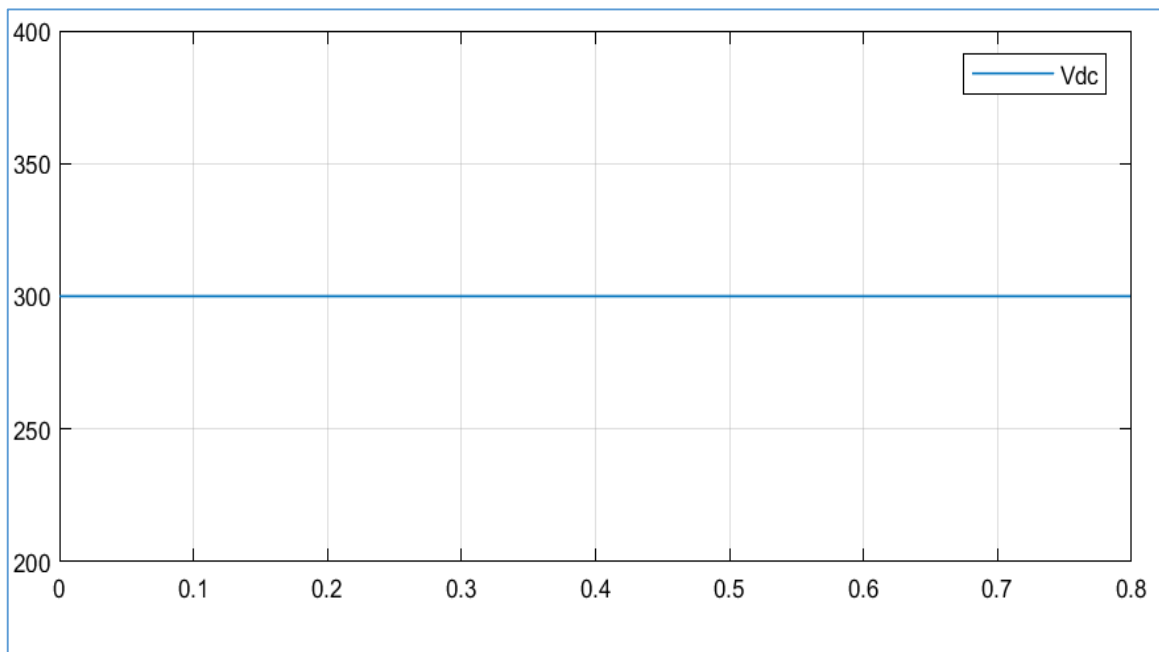

Fig n°29: DC Voltage V_{dc} (Hysteresis).

Where this represent the direct voltage that enter to the inverter, its constant on value 300v in order to get on the phase peak 157v

III.6.2. Hysteresis controller under abnormal grid conditions

Now we'll test how the regulator deal with those problems by showing the result that we got it to analyse, at the time [0.1,0.2] we add nonlinear load than at the time [0.6,0.7] we make unbalanced system

The simulation results below, show us that the regulator has a really good dynamic response additionally it is rough against load changes but it finds it strongly difficult to decoupling current frame dq in the figure 30 of the inner loop (current loop) which is distorted on I_q is not stable on 0 because of outer loop (voltage loop) of Synchronous Reference Frame Voltage v_{dq} (Hysteresis) in the figure 31 which has many oscillations without stability and full of harmonic.

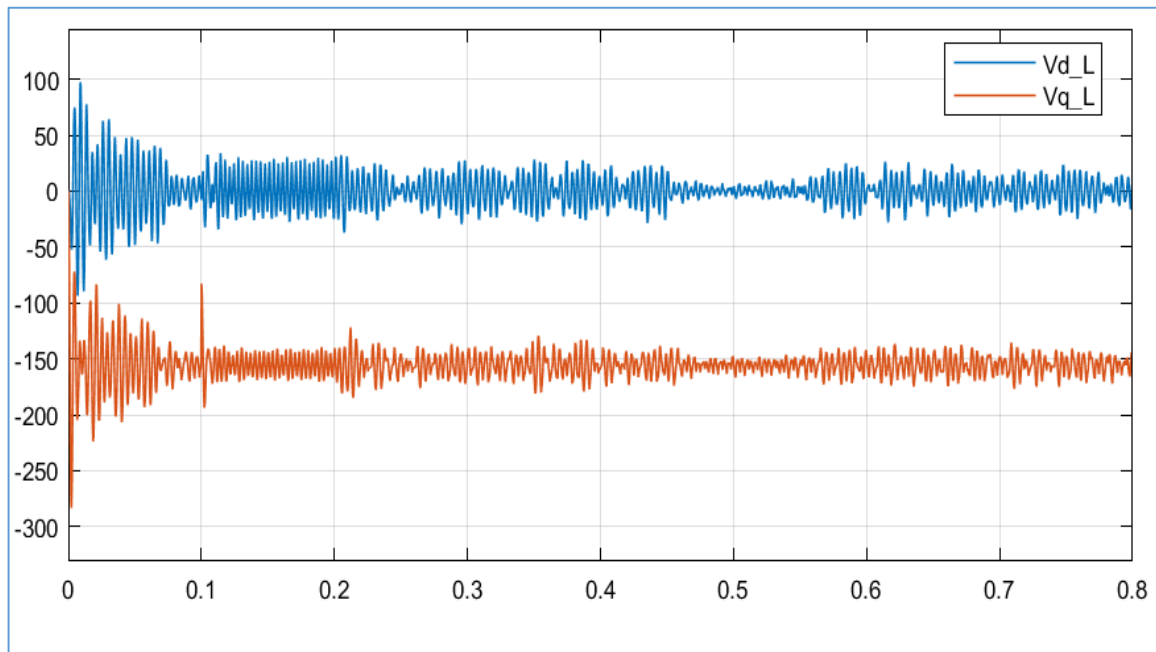

Fig n°30: Synchronous Reference Frame Voltage v_{dq} (Hysteresis).

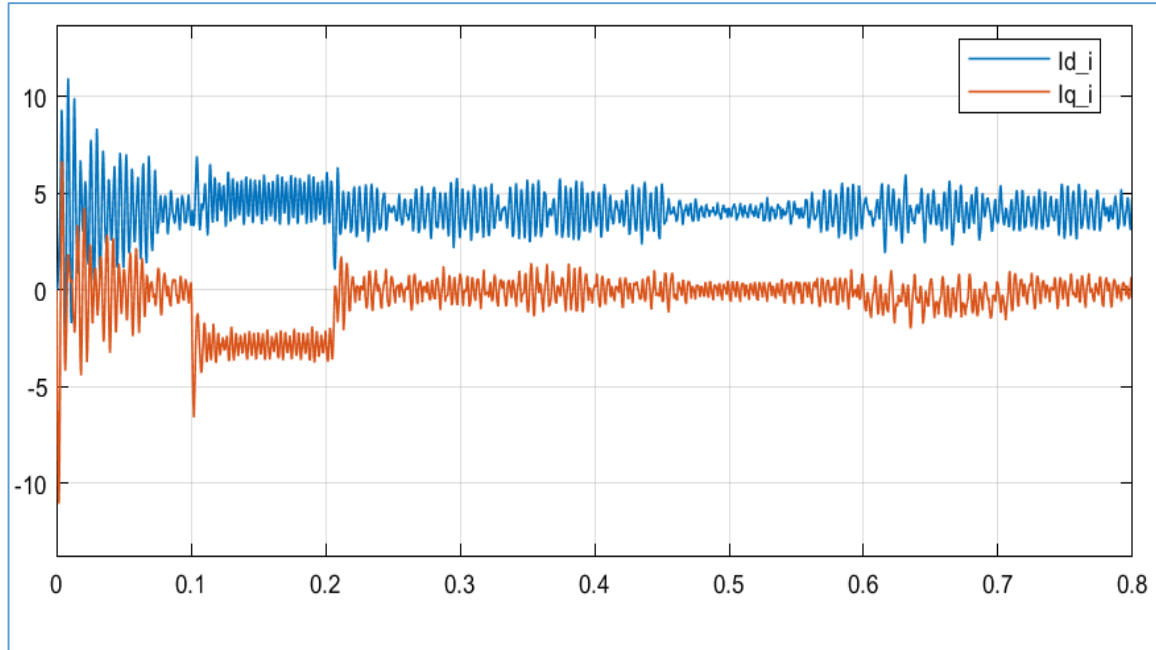

Fig n°31: Synchronous Reference Frame Current of the inverter Idq (Hysteresis).

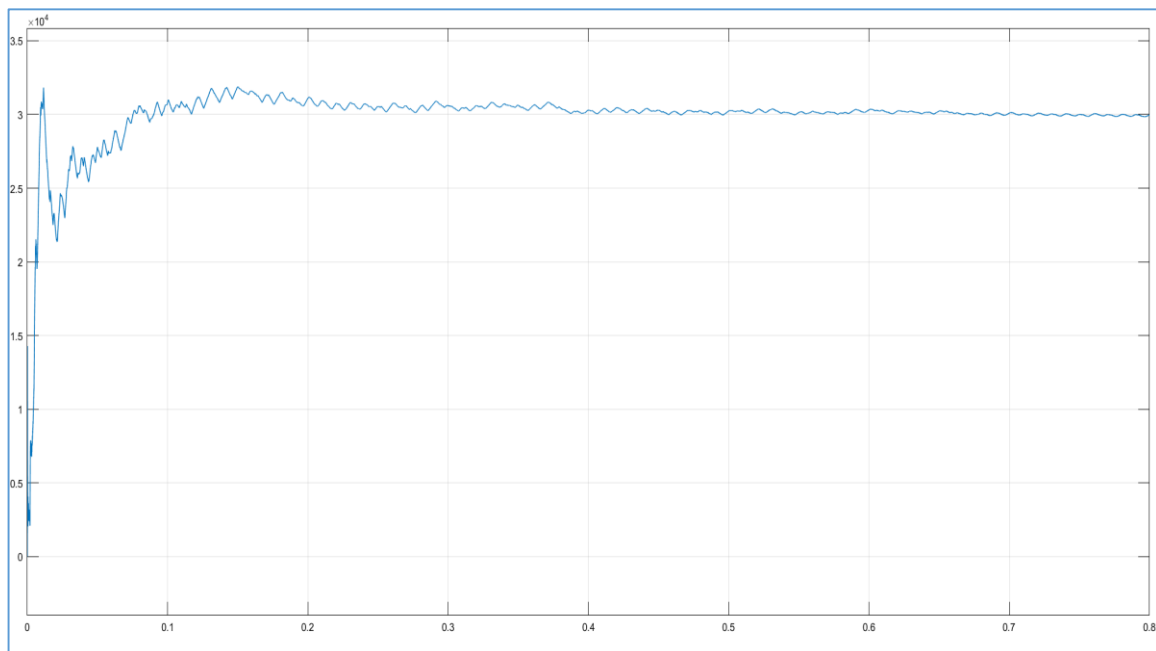

Fig n°32: Switching frequency (Hysteresis).

The switching frequency (Fig n°32) changes according to variations of the load parameters and operating conditions. This is one of the major drawbacks of hysteresis control, since variable switching frequency can cause resonance problems. In addition, the switching losses restrict the application of hysteresis control to lower power levels [15].

After studying the hysteresis control technology, we noticed the following Points:

This method is conceptually simple and the implementation does not require complex circuits or processors. The performance of the hysteresis controller is good, with a fast dynamic response. Due to the interaction between the phases, the current error is not strictly limited to the value of the hysteresis band.

Another important performance measure is the output current spectrum generated by the inverter. Hysteresis control produces a continuous and wide frequency range output voltage spectrum which happens to be a disadvantage. [16]

III.7. Control of system based on SPWM technique:

III.7.1. PI controller under abnormal grid condition:

The proportional integral (PI) current control scheme employs a free-running fixed-frequency carrier signal resulting in a fixed-frequency inverter operation and a well-defined output current harmonics. Typical advantages of such a scheme include absence of the effect of DC-side ripple on the inverter load side waveforms, fixed inverter switching frequency, free running carrier operation and instantaneous takeover of current control.

Although the frequency of operation can be chosen independently, limitations are imposed by the value of the load inductance at the switching frequency. The load inductance current increases, which requires an increase in the amplitude and/or the frequency of the carrier signal. With this method, constant switching frequency, fixed by the carrier is obtained. Although the PI controller assures zero SteadyState error for continuous reference, it can present such an error for sinusoidal references [10]. This error increases with the frequency of the reference current and may become unacceptable for certain applications. The design of PI controller can be done by using several methods. It can be designed using Ziegler-Nicholas, pole placement method and frequency response. Determines the

slope of the current and therefore the existence of the intersections required to create the PWM pattern. on the figure 33 it is shown Synchronous Reference Frame Voltage v_{dq} on pi regulator which is gated by transform the the measured capacitor voltage to dq frame ,this one compared to the reference in the outer loop (voltage loop) in order to give the reference current on dq frame (I_{dq}^*) , the figure 34 represents the Synchronous Reference Frame current I_{dq} which is gated by transform the measured inductor current to the dq frame ,this one compared to the reference in inner loop(current loop) on pi controller The error between the reference and the measured load current is processed by a PI controller to generate the reference voltages. A modulator is needed to generate the drive signals for the inverter switches. The reference load voltages are compared with a triangular carrier signal, and the output of each comparator is used to drive an inverter leg. [17] and [16]

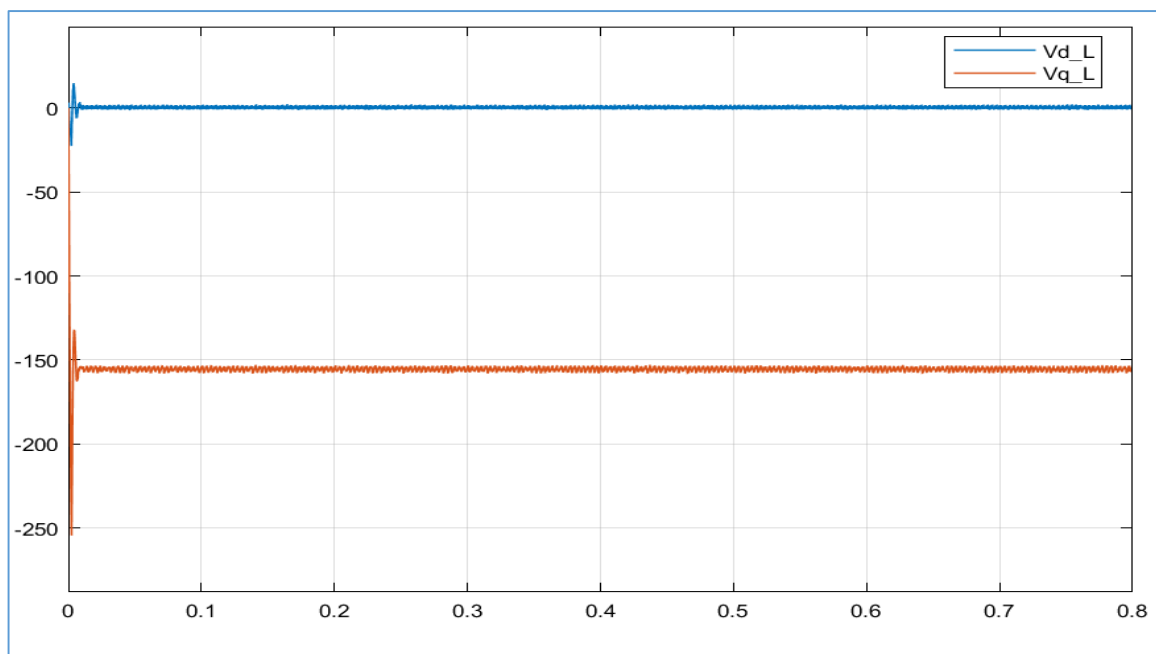

Fig n°33: Synchronous Reference Frame Voltage v_{dq}

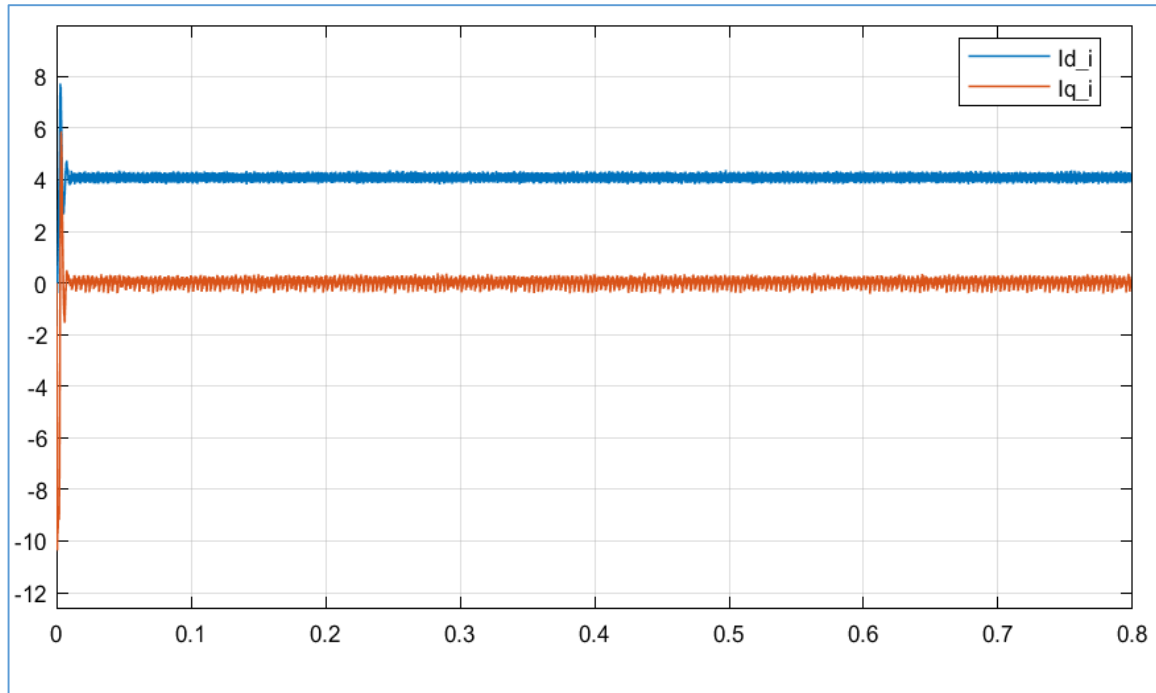

Fig n°34: Synchronous Reference Frame Current Inverter Idq

PI regulator provide better quality power output current based on THD and ease of filter design, and of course better power quality transformation between grid and renewable energies source.

III.7.2.PI controller under abnormal grid conditions:

We are going to make the same test with pi controller to insure its performance under abnormal condition at the time [0.2,0.4] we add nonlinear load to the system, the effect of this problem distort the voltage wave form and make it full of harmonics, the performance of pi controller shows on the figure 35 of Synchronous Reference Frame Voltage v_{dq} of the load of PI controller that the tow signals are pure, on the figure 36 of

Synchronous Reference Frame Current Idq of the load (PI)The regulated current using PWM technique shows better coupling effects between id and iq. The harmonic content generated when using PWM current control is concentrated around the carrier frequency [17].

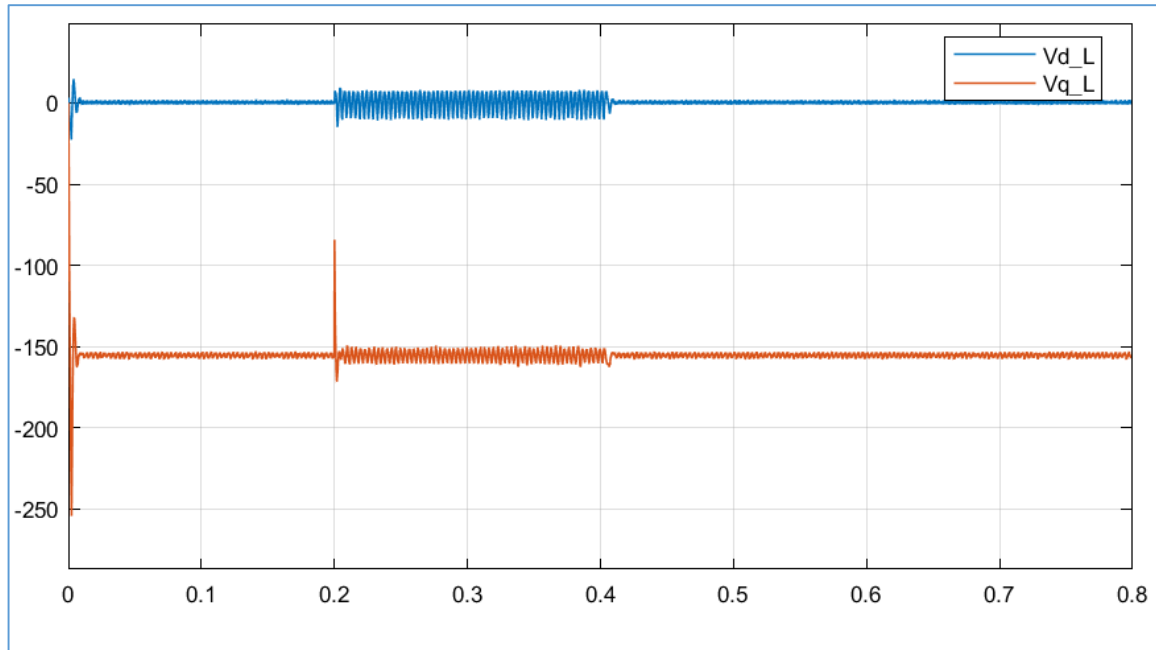

Fig n°35: Synchronous Reference Frame Voltage v_{dq} of the load (PI)

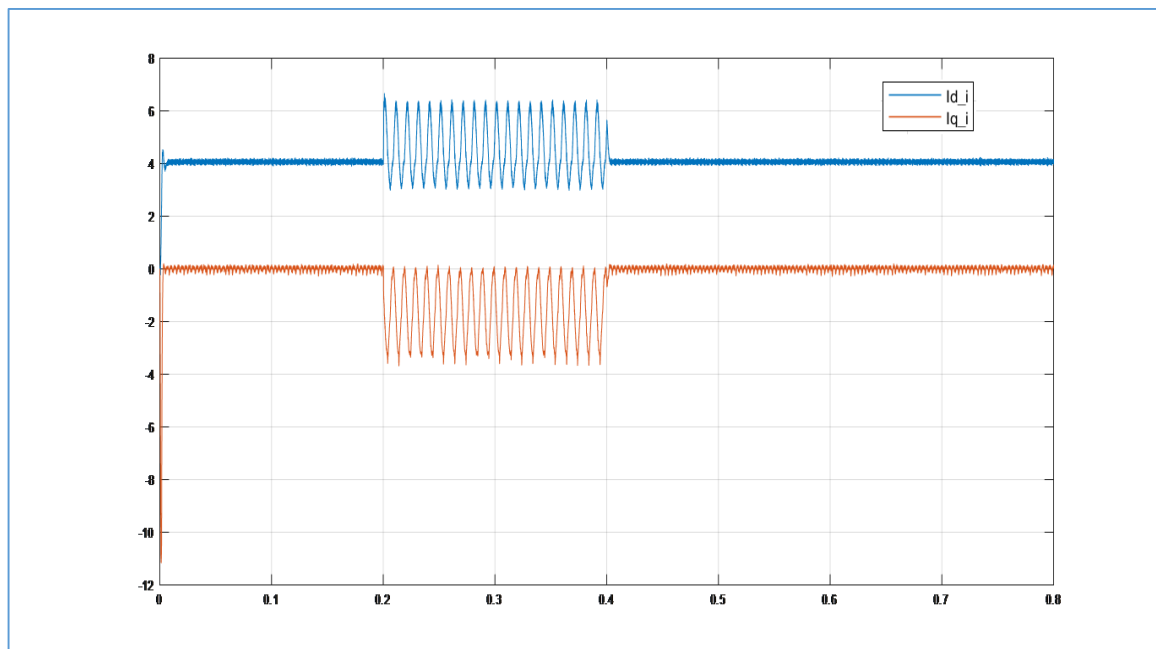

Fig n°36: Synchronous Reference Frame Current I_{dq} of the load (PI)

at the time [0.6,0.7] we connect unbalance system in order to test regulator,

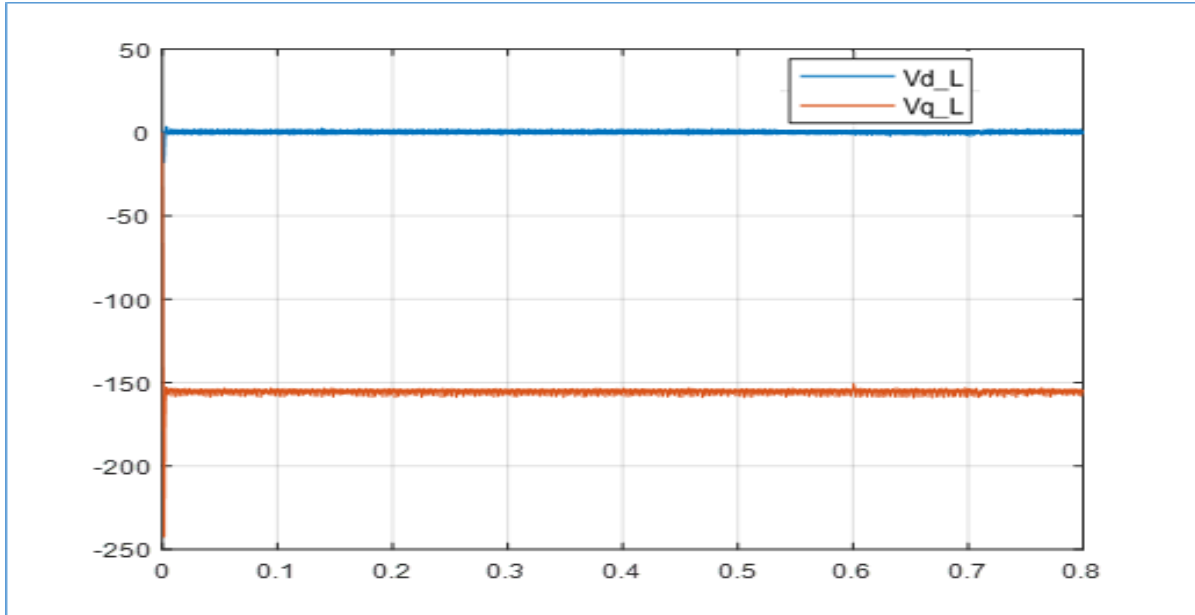

Fig n°37: Synchronous Reference Frame Voltage V_{dq} Inverter (PI)

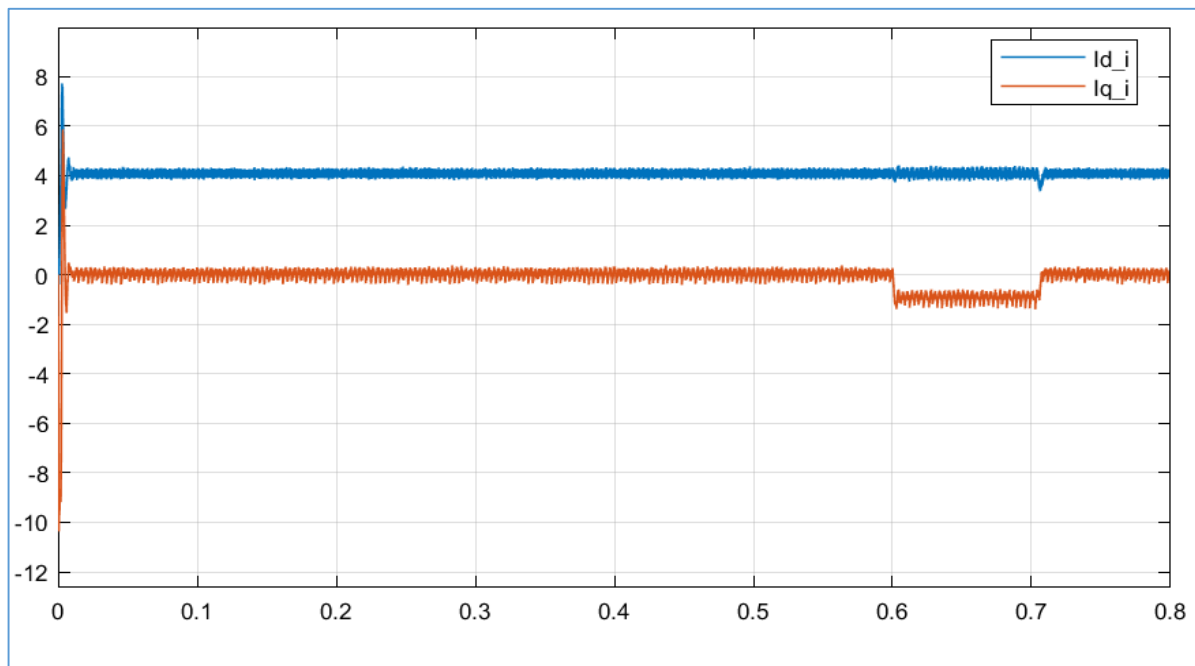

Fig n°38: Synchronous Reference Frame Current I_{dq} Inverter (PI)

The result above on figure 37,38 show us the response of pi regulator under abnormal condition (unbalanced system), the error in pi regulator between the reference and the measured load current to generate the reference voltages of PWM, as it is shown that form of control signal is accepted and the decoupling in current is done so pi controller work successfully.

After studying the hysteresis control technology, we noticed the following Points:

The parameters tested and observed were compared for the performance of the hysteresis control and PI control with PWM techniques are shown. As the load value increases, the THD value also increases but the PI controller shows better response compared to the Hysteresis Controller. From Figures above it can be observed that hysteresis control produces continuous and wide frequency range output voltage spectrum, which is considered disadvantage of this method. Also it was observed that while using PWM current control, the harmonic content generated is concentrated around the carrier frequency. This is considered an advantage of PWM over hysteresis control.[16]

The performance of hysteresis current controller and Proportional-Integral current controller using PWM technique for the Voltage Source Inverter were tested for different voltage loads. Hysteresis controller shows good dynamic response but with some noticeable coupling effect. In hysteresis controller while increase in load values, THD also increases due to the time constant RL load. The Proportional-Integral current controller shows slight coupling effect and provides better total harmonic distortion than hysteresis current controller. The simulation results showed that both the controllers are capable of producing good output current regulation.

PI has several drawbacks such as slow dynamic response and non-zero steady state error. When both controllers are combined together, the system is considered to be more stable and reliable enough to mitigate any sorts of harmonic content in signals.

III.8. Experimental Results:

III.8.1. The dSPACE:

The dSPACE 1104 development board provides an integral solution for the practical implementation of the different control techniques of these converters.

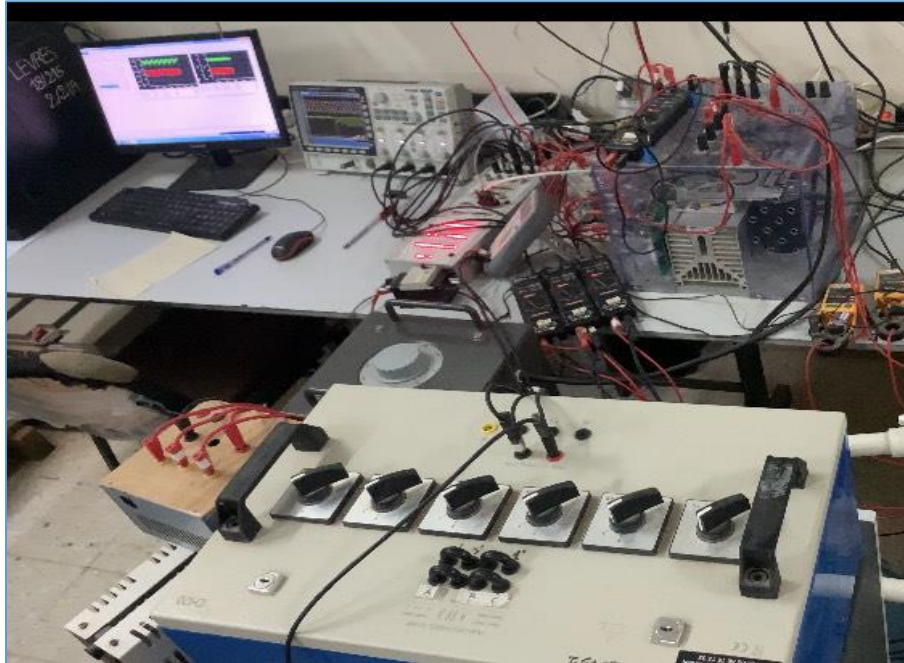

Fig n°39: Three-phase grid-forming inverter test rig.

The performance of the SRF-PLL and three phase load voltage are shown in Figure 40 of the simulation results below. The performance of the PLL is shown for a purely sinusoidal load voltage which is the ideal case than for distorted load voltage on abnormal condition by nonlinear load, and is rarely encountered in practice, though a strong grid does not deviate too far from this ideal case. The PLL is tuned to have the same bandwidth by reset mode which shows the sequence during synchronization process for comparison and it show accepted accuracy in tracking the voltage angle,

however, in the figure 43 which is shown the PLL frequency on abnormal condition with many oscillations full of harmonic signals and unaccepted performance in tracking the frequency of the system

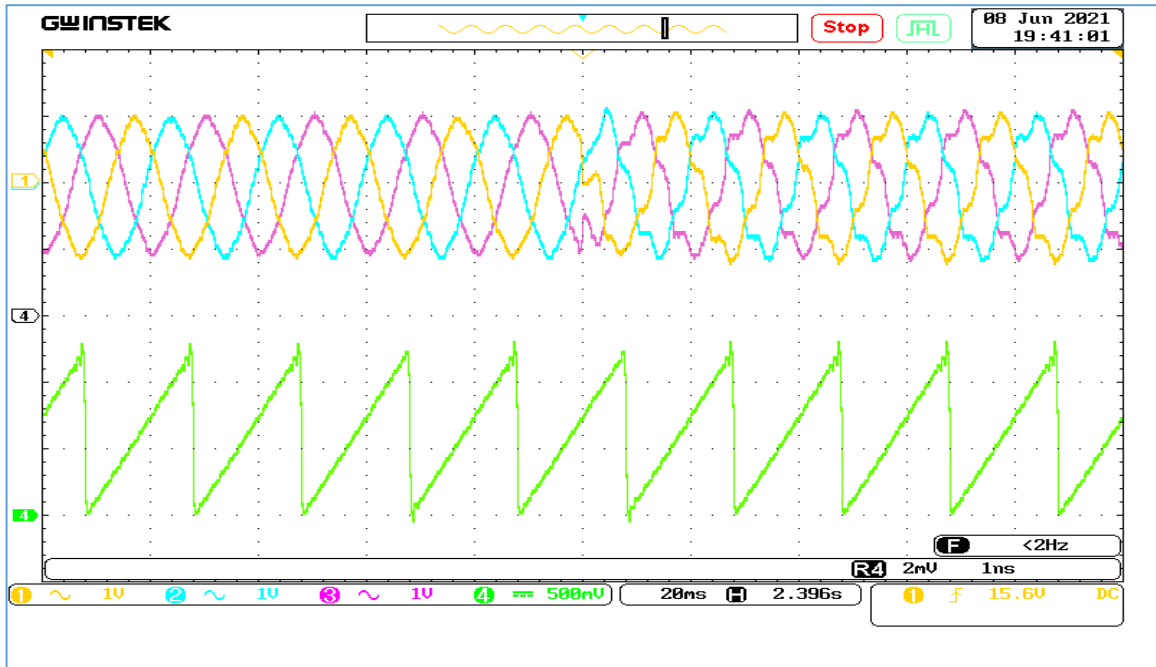

Fig n°40: Three-phase Voltage and angle.

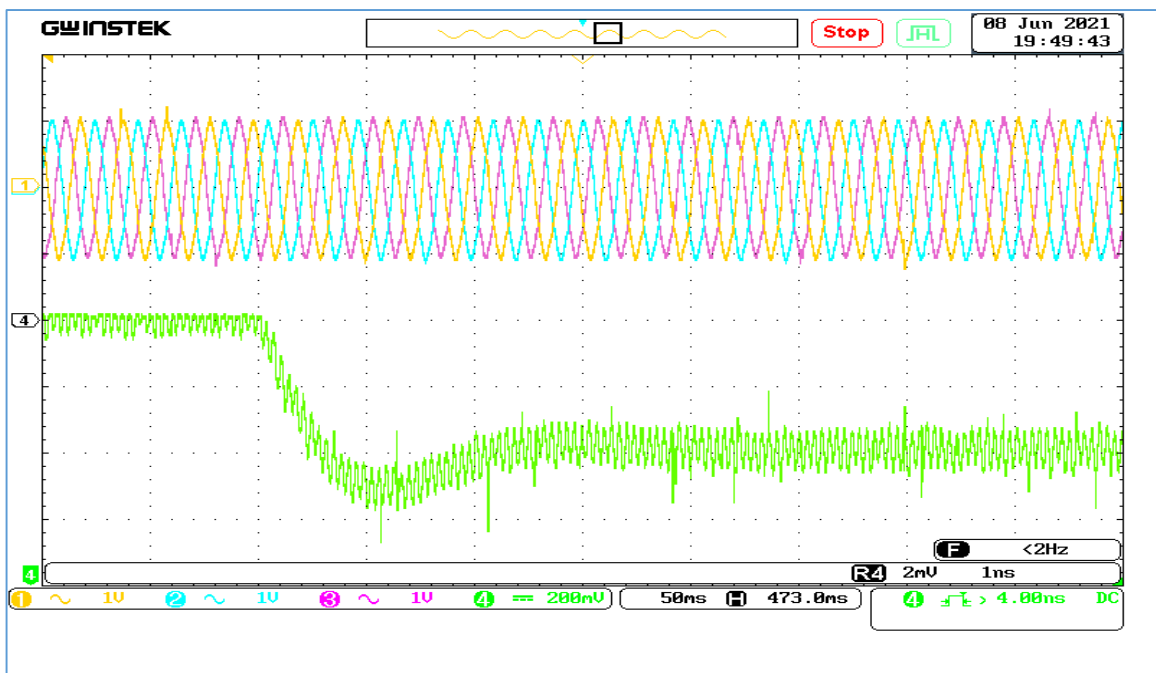

Fig n°41: Three-Phase Load Voltage and Frequency (Frequency decreasing)

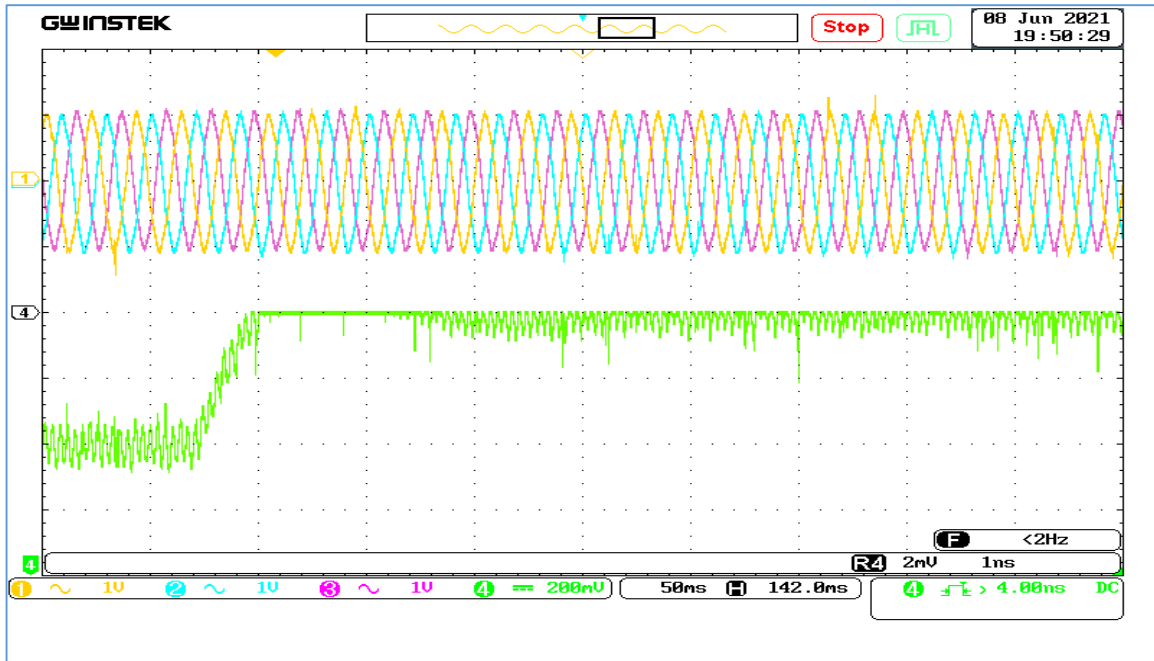

Fig n°42: Three-Phase Load Voltage and Frequency (Frequency Increasing)

The figures 41,42 above provide the way of system react on case of increasing or decreasing frequency and it means abnormal condition cases of course

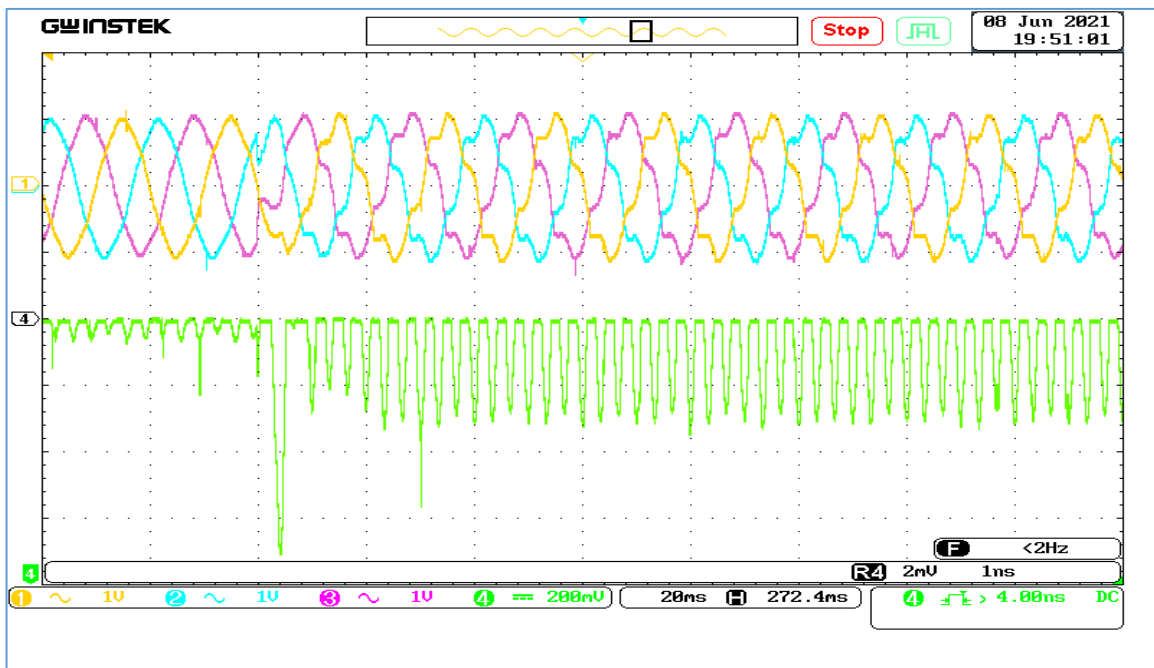

Fig n°43: Three-phase Voltage and Switching Frequency

Chap III: Simulation and Experimental Results

In order to ensure the performance of pi controller we test it in abnormal condition which is the reduce of voltage of the simulation result below,

the figure 44 represents the load voltage and the pll frequency on case of reduce the voltage reference, it is shown that the regulation has good performance fast response on the load voltage



Fig n°44: Three-phase Voltage and Frequency

III.9. Chapter Summary:

In this chapter, the influence regarding the current control scheme for the three-phase grid-forming inverter has been considered. The simulation and experimental results for the three-phase grid-connected inverter were presented using PI controllers. In the three-phase grid Forming system, current control can be implemented in various ways such as the synchronous rotating reference frame dq, and the stationary reference frame $\alpha\beta$ in a rotating reference frame with angular frequency using Clark's and Park's transformations.

The current control schemes used are the PI controllers under normal and abnormal conditions. The simulation and practical results show that the PI and hysteresis current controllers are able to control the system in general under normal grid conditions but suffer in abnormal conditions.

The simulation performance of hysteresis current controller and Proportional-Integral current controller using PWM technique for the Voltage Source Inverter were tested for different voltage loads. Hysteresis controller shows good dynamic response but with some noticeable coupling effect. In hysteresis controller while increase in load values, THD also increases due to the time constant RL load. The Proportional-Integral current controller shows slight coupling effect and provides better total harmonic distortion than hysteresis current controller. [2]

The experiment results showed that the PI controllers based on SPWM techniques are capable of producing a better output current regulation.

PV systems have shown significant growth in recent years driven by increased efficiency and reductions in the cost of PV modules. Today, photovoltaic systems based on distribution generation have an important contribution to the total electricity production worldwide.

This thesis focused on improving the power quality of the grid current by comparison between Hysteresis Controller and PI Controller in single-phase grid-connected PV inverter systems. In particular, it concerns about improving the harmonic performance of grid current under the variation of grid operating conditions.

also presents fundamental concepts of PV power generation systems and It highlights the importance of renewable energy by giving statistics and advantages of renewable energy compared to non-renewable energy and how recent studies are searching for ways to make its price cheaper and its power more effective. Moreover, its defines it defines the general structure of distributed power generation and it gives an explanation about three-phase Grid- Forming Inverter and what the different between the last one with Grid-feeding and Grid-Supporting, then it gives general information about grid filters such as L, LC, LCL and what's the best filter for harmonic attenuation and Finally we mentioned different methods of Grid Synchronization and specially PLL

Additionally, it gives deep understanding on grid-forming system model and its control Technical include the modelling of VSI who's method in which the inverter is represented mathematically in order to be used later in the third chapter for the simulations by Matlab software.

Current-controlled pulse width modulated (PWM) voltage source inverters are most widely used in high performance AC drive systems, as they provide high dynamic response. A comparative study between the Hysteresis controller and Proportional-Integral controller using PWM techniques for three-phase voltage source inverter was done. The comparison was done in terms fast dynamic response and output current quality, Simulation was done with the help of Matlab-Simulink environment. The hysteresis controller provides good dynamic performance, whereas the Proportional-Integral controller provides instantaneous current control and wave shaping, fixed inverter switching frequency resulting in better harmonics [18].

References

- [1] Younis, M. A. A., Rahim, N. A., & Mekhilef, S. (2011, September). Simulation of grid connected THIPWM-three-phase inverter using SIMULINK. In 2011 IEEE Symposium on Industrial Electronics and Applications (pp. 133-137). IEEE.
- [2] Khalfalla, H. O. (2019). Adaptive proportional resonant controller for single-phase grid-connected PV inverter based on grid impedance estimation technique (Doctoral dissertation, Newcastle University).
- [3] Bouzid, A. M., Guerrero, J. M., Cheriti, A., Bouhamida, M., Sicard, P., & Benghanem, M. (2015). A survey on control of electric power distributed generation systems for microgrid applications. *Renewable and Sustainable Energy Reviews*, 44, 751-766.
- [4] Althobaiti, A. O. (2018). Proportional resonant control of three-phase grid-connected inverter during abnormal grid conditions (Doctoral dissertation, Newcastle University).
- [5] Kahlane, A. E. W. H., Hassaine, L., & Kherchi, M. (2014). LCL filter design for photovoltaic grid connected systems. *the Journal of Renewable Energies*, 227-232.
- [6] <https://www.sciencedirect.com/topics/engineering/forming-converter>
- [7] J. Holtz, "Pulsewidth modulation-a survey," *IEEE Transactions on Industrial Electronics*, vol. 39, pp. 410-420, 1992.
- [8] Kim, S. H. (2017). *Electric motor control: DC, AC, and BLDC motors*. Elsevier.
- [9] V.G. Agelidis, P.D. Ziogas, G. Joos, 'Dead-Band' PWM switching patterns, *IEEE Trans. Power Electron.* 11 (4) (July, 1996) 522531.
- [10] M.P. Kazmierkowski, M.A. Dzieaniakowski 'Review of Current Regulation Methods For VS-PWM Inverters' 0-7803-1227-9/93/\$3.009 1993 IEEE
- [11] H. Rashid, *Power Electronics: Circuits, Devices, and Applications*: Pearson/Prentice Hall, 2004.
- [12] Mulolani, F. (2017). Performance of direct power controlled grid-connected voltage source converters (Doctoral dissertation, Newcastle University).
- [13] Rizqiawan, A., Hadi, P., & Fujita, G. (2019). Development of grid-connected inverter experiment modules for microgrid learning. *Energies*, 12(3), 476.
- [14] مهدوی، محمدسعید، فتحی، سیدحمید، & خدادوست آرانی (2019). Chopper-based real-time load emulator with feed-forward and hysteresis current controller. 59-49, (4)15, نشریه مهندسی برق و الکترونیک ایران.
- [15] Sundararajan, K., Nachiappan, A., & Veerapathiran, G. (2012). Comparison of current controllers for a five-level cascaded H-bridge multilevel inverter. *Int. J. Comput. Eng. Res.(ijceronline. com)*, 2(6), 55-62.
- [16] Rodriguez, J., Pontt, J., Silva, C. A., Correa, P., Lezana, P., Cortés, P., & Ammann, U. (2007). Predictive current control of a voltage source inverter. *IEEE transactions on industrial electronics*, 54(1), 495-503.
- [17] Maswood, A. I., & Rahman, M. A. (1996). Performance parameters of a pulse-width modulation voltage source inverter with proportional-integral controller under non-ideal conditions. *Electric power systems research*, 38(1), 19-24.
- [18] Nachiappan, A., Sundararajan, K., & Malarselvam, V. (2012, January). Current controlled voltage source inverter using Hysteresis controller and PI controller. In 2012 International Conference on Power, Signals, Controls and Computation (pp. 1-6). IEEE.