

**PEOPLE'S DEMOCRATIC REPUBLIC OF ALGERIA
MINISTRY OF HIGHER EDUCATION AND SCIENTIFIC
RESEARCH
El-Echahid HAMMA Lakhdar EL OUED University**



**Faculty of Technology
Mechanical Engineering Department
Course Handout
(Level: 2nd year Energy Master)**

Transport and Storage of Energy

Prepared By: Dr. Mohammed Iliasse BOULIFA

University year: 2024-2025

CONTENTS	
Forewords	1
Chapter 1: Different forms of energy	
I. Definition of energy	2
II. forms of energy	2
1. <i>Mechanical energy</i>	2
2. <i>Electrical energy</i>	3
3. <i>Thermal energy</i>	3
4. <i>Chemical energy</i>	4
5. <i>Light energy</i>	5
6. <i>Nuclear energy</i>	5
7. <i>Sound Energy</i>	6
8. <i>Elastic Energy</i>	7
III. Conservation and transformation of energy	8
Chapter 2: Energy management: production, transformation, transport and storage	
I. Definition of energy management	11
II. Production of Energy: Overview and Methods	11
1. <i>Non-Renewable Energy Sources</i>	11
2. <i>Renewable Energy Sources</i>	12
3. <i>Emerging Energy Technologies</i>	14
III. Energy Transport	14
1. <i>Transportation of Fuels</i>	14
2. <i>Transport of Electrical Energy</i>	15
3. <i>Transport of Hydraulic Energy</i>	15
4. <i>Transport of Thermal Energy</i>	15
IV. Storage of Electrical Energy	16
1. <i>Electrochemical Storage of Electrical Energy</i>	16
2. <i>Electrostatic Storage of Electrical Energy</i>	16
3. <i>Kinetic Storage of Energy</i>	16
4. <i>Energy Storage in Hydraulic Form</i>	17
5. <i>Energy Storage in the Form of Compressed Air</i>	17

6. <i>Energy Storage in the Form of Heat</i>	17
7. <i>Energy Storage in the Form of Hydrogen</i>	18
Chapter 3: Energy Transport	19
I. Fuel Transport	19
1. <i>Pipeline transport mode</i>	19
2. <i>Road transport mode</i>	23
3. <i>Rail transport mode</i>	26
4. <i>Maritime transport mode</i>	31
II. Electric power transport	35
1. <i>Electric power generation and transmission</i>	35
2. <i>Voltage ranges</i>	36
3. <i>Power transmission problem</i>	36
4. <i>Structure of the transmission and distribution network</i>	36
5. <i>The cables</i>	37
6. <i>Underground lines</i>	38
<i>Advantages of Electric Power Transport</i>	39
<i>Challenges in Electric Power Transport</i>	40
<i>Innovations in Electric Power Transport</i>	41
III. Hydraulic energy transport	42
1. <i>Open-Channel Flow</i>	42
2. <i>Pressurized Pipelines</i>	42
3. <i>Pumped-Storage Systems</i>	43
3. <i>Pumped-Storage Systems</i>	43
4. <i>Penstocks</i>	44
5. <i>Tunnels and Aqueducts</i>	44
6. <i>Hydraulic Accumulators</i>	45
7. <i>Gravity-Based Systems</i>	46
8. <i>Tidal and Wave Energy Transport</i>	46
<i>Comparison of Methods</i>	47
IV. Thermal energy transport	48
1. <i>Conduction</i>	48
2. <i>Convection</i>	49

3. Radiation	49
4. Heat Pipes	50
5. Thermoelectric Systems	51
6. Phase Change Materials (PCMs)	52
Comparison of Methods	53
Chapter4: Energy Storage	54
Why store energy?	54
I. Interest	54
II. Energy storage efficiency	55
III. Forms of energy storage	56
1. Mechanical storage	56
2. Electrochemical and Electrostatic storage storage	60
3. Chemical storage	67
4. Thermal and thermochemical storage	70
5. New storage technologies	74
IV. Cost of energy storage	75
V. References	76

Foreword

The Transport and Storage of Energy course provides a comprehensive exploration of the principles, technologies, and challenges involved in moving and storing energy efficiently and sustainably. As the world transitions to renewable energy sources like solar, wind, and hydrogen, understanding how energy is transported and stored is critical for ensuring reliability, affordability, and environmental sustainability.

The course covers:

- **Energy Transport:** Infrastructure such as power grids, pipelines, and transportation networks for moving electricity, heat, and chemical energy from production to consumption.
- **Energy Storage:** Technologies like batteries, pumped hydro, hydrogen storage, and thermal systems that store energy for later use, balancing supply and demand.
- **Challenges:** Integration of renewables, efficiency losses, infrastructure costs, and environmental impacts.
- **Innovations:** Emerging solutions such as solid-state batteries, green hydrogen, and advanced thermal storage.

Through theoretical knowledge, case studies, and hands-on projects, the course equips students with the skills to design and optimize energy systems. It is ideal for engineers, policymakers, and anyone passionate about building a sustainable energy future. Join us to explore the critical role of energy transport and storage in shaping a cleaner, more resilient world.

This course handout for the teaching of energy transport and storage is intended for students in the 2nd year of the master's degree in energy within the field of Science and Technology. The handout presents a version adapted to the program proposed by the Ministry of Higher Education and Scientific Research. The course covers the fundamental concepts of energy transport and storage. The content of this course is the result of bibliographical research based on numerous documents reference works.

Chapter 1: Different forms of energy

I. Definition of energy

Energy is the ability to do work or cause change. It exists in various forms, such as kinetic, potential, thermal, chemical, and electrical energy, and can be transferred or transformed from one form to another. Energy is essential for all physical and biological processes, powering everything from natural phenomena to human-made machines.

II. forms of energy

Energy is used to do work, to apply a force to a system, to move it or change its movement, to provide heat, etc.

Energy can be located in potential or kinetic form: Energy is available in potential form, and it is used in kinetic form. The source is a reservoir containing a fluid (oil, air under pressure, compressed spring, water retained by a dam, electric battery, etc.).

Kinetic Energy

- Energy of motion.
- Examples: A moving car, flowing water, wind.

Potential Energy

- Stored energy due to position or state.
- Examples: A stretched rubber band, water behind a dam, a book on a shelf.

1. Mechanical energy: provided by a moving fluid (water current in a river, wind, tides), by a spring or a compressed fluid, by gravity.

Mechanical energy is the sum of kinetic energy (energy of motion) and potential energy (stored energy due to position or state) in a system. It is associated with the movement and position of objects.

Examples:

- A **swinging pendulum** (energy shifts between kinetic and potential).
- A **moving car** (kinetic energy from motion).
- A **stretched bow** (potential energy stored before release).
- Water in a **hydroelectric dam** (potential energy in stored water, converted to kinetic energy when released).

Mechanical energy is **conserved** in a system without external forces like friction or air resistance. However, in real-world scenarios, some energy may transform into heat or sound due to friction.

Formula Mechanical Energy=Kinetic Energy+Potential Energy

$$ME=KE+PE$$

2. Electrical energy: associated with magnetism, electric current.

Electrical energy is the energy caused by the movement of **electric charges (electrons)**. It is a form of energy that can be easily converted into other types, such as light, heat, or mechanical energy.

Sources of Electrical Energy:

1. **Batteries:** Convert chemical energy into electrical energy.
2. **Power Plants:** Generate electricity from various sources (coal, hydro, nuclear, solar, etc.).
3. **Lightning :** A natural discharge of electrical energy.

Examples of Electrical Energy in Use:

- Light bulbs (convert electrical energy into light and heat).
- Electric motors (convert electrical energy into mechanical energy).
- Computers and appliances (powered by electricity).

Formula (for electrical power):

$$P=V \times I \quad (1)$$

Where:

P = Power (Watts)

V = Voltage (Volts)

I = Current (Amperes)

3. Thermal energy: provided by the combustion of coal, oil, gas,

Thermal energy, also known as heat energy, is the total energy of the particles in a substance due to their motion. It is a form of kinetic energy because it arises from the movement of atoms and molecules. The faster the particles move, the higher the thermal energy and temperature.

Characteristics:

- Depends on mass, temperature, and material type.
- Flows from hotter objects to cooler ones until equilibrium is reached.
- Can be transferred via conduction, convection, or radiation.

Sources of Thermal Energy:

- **The Sun:** The primary natural source of heat.
- **Fire:** Releases thermal energy through combustion.
- **Geothermal Energy:** Heat from inside the Earth.
- **Friction:** Converts mechanical energy into heat.
- **Electric Heaters:** Convert electrical energy into heat.

Examples of Thermal Energy in Action:

- Boiling water (heat makes molecules move faster).
- A hot cup of coffee (loses thermal energy to the surroundings).
- Burning wood (chemical energy is converted into heat and light).

Formula (for heat transfer)

$$Q=mc\Delta T \quad (2)$$

Where:

Q = Heat energy (Joules)

M = Mass (kg)

c = Specific heat capacity (J/kg°C)

ΔT = Change in temperature (°C)

4. Chemical energy: supplied by food, by an electric battery.

Chemical energy is the potential energy stored in the bonds of chemical compounds (such as molecules and atoms). It is released or absorbed during chemical reactions, often producing heat, light, or other forms of energy.

Characteristics:

- Stored in chemical bonds between atoms.
- Released or absorbed during chemical reactions (example: combustion, digestion).
- Can be converted into other energy forms (example: electrical, thermal, mechanical...).

Sources of Chemical Energy:

- **Food:** The body breaks down food to release energy.
- **Batteries:** Chemical reactions generate electrical energy.
- **Fossil Fuels:** Gasoline, coal, and natural gas release energy when burned.
- **Wood and Biomass:** Combustion converts stored energy into heat and light.
- **Explosives:** Rapid chemical reactions release large amounts of energy.

Examples of Chemical Energy in Action:

- A car engine burning gasoline (chemical energy → mechanical energy).
- Photosynthesis (plants store sunlight as chemical energy).
- A lit candle (chemical energy → heat + light).
- A charged battery powering a flashlight (chemical → electrical → light energy).

5. Light energy: useful for plants, which use photosynthesis,

Light energy, also known as radiant energy or electromagnetic energy, is a form of energy that travels in **waves** and can move through space (a vacuum). It is a type of kinetic energy because it consists of moving photons.

Characteristics:

- Travels in the form of electromagnetic waves.
- Can move through space without a medium (unlike sound energy).
- Includes visible light and other electromagnetic waves (radio, microwaves, infrared, ultraviolet, X-rays, gamma rays).

Sources of Light Energy:

- **The Sun:** The primary natural source.
- **Light Bulbs:** Convert electrical energy into light.
- **Lasers:** Produce concentrated beams of light.
- **Fire & Candles:** Emit light through combustion.
- **Bioluminescent Organisms** – Some living things (e.g., fireflies, deep-sea fish) produce light chemically.

Examples of Light Energy in Action:

- **Photosynthesis:** Plants use sunlight to create food.
- **Solar Panels:** Convert sunlight into electricity.
- **Vision:** The human eye detects visible light.
- **Fiber Optic Cables:** Use light for high-speed communication.

Properties of Light Energy:

- **Wavelength (λ):** Determines the type of electromagnetic wave.
- **Frequency (f):** Higher frequency means more energy (example: X-rays have more energy than radio waves).
- **Speed:** Light moves at 299,792,458 m/s in a vacuum.

6. Nuclear energy: present in atoms, obtained by fusion or fission.

Nuclear energy is the energy stored in the nucleus of an atom. It is released when atomic nuclei undergo fission (splitting) or fusion (combining). This energy is incredibly powerful and is used in both peaceful applications (like electricity generation) and destructive ones (like nuclear weapons).

Types of Nuclear Reactions:**1. Nuclear Fission (Splitting Atoms)**

- A heavy nucleus (example: uranium-235, plutonium-239) splits into smaller nuclei, releasing energy.
- Used in nuclear power plants and atomic bombs.
- Example: $U_{235} + \text{neutron} \rightarrow Ba^{141} + Kr^{92} + 3 \text{ neutrons} + \text{energy}$

2. Nuclear Fusion (Combining Atoms)

- Two light atomic nuclei (example: hydrogen isotopes) fuse to form a heavier nucleus, releasing immense energy.
- Powers the Sun and stars.
- Example: $H^2 + H^3 \rightarrow He^4 + \text{neutron} + \text{energy}$
- Future potential for clean energy (fusion reactors under development).

Sources of Nuclear Energy:

- **The Sun and Stars:** Nuclear fusion reactions power them.
- **Nuclear Power Plants:** Use fission to generate electricity.
- **Nuclear Weapons:** Use fission or fusion for massive energy release.
- **Radioactive Decay:** Some isotopes naturally release nuclear energy over time (used in medicine, space probes, etc.).

Examples of Nuclear Energy :

- Electricity from nuclear power plants (fission heats water to produce steam, turning turbines).
- The Sun's heat and light (fusion of hydrogen into helium).
- Nuclear submarines and spacecraft (small nuclear reactors power them).
- Cancer treatment (radiotherapy) (uses radioactive isotopes).

7. Sound Energy

Sound energy is a form of mechanical energy that travels in the form of vibrations through a medium (such as air, water, or solids). It is produced when an object vibrates, causing the surrounding particles to move in a wave-like pattern.

Characteristics:

- Requires a medium to travel (cannot move through a vacuum like space).
- Travels in longitudinal waves (compression and rarefaction).

- The speed of sound depends on the medium (fastest in solids, slower in liquids, and slowest in gases).

Sources of Sound Energy:

- **Musical Instruments:** Vibrating strings, air, or surfaces create sound.
- **Human Voice:** –Vocal cords vibrate to produce sound.
- **Speakers:** Convert electrical energy into sound waves.
- **Thunder:** A result of air expanding due to lightning.
- **Machinery and Vehicles:** Engines and moving parts generate sound.

Examples of Sound Energy:

- A ringing bell (vibrations create sound waves).
- Echoes in a canyon (sound waves reflecting off surfaces).
- Ultrasound in medical imaging (high-frequency sound waves for scanning).
- Seismic waves (earthquakes produce low-frequency sound energy).

formula for Sound Energy:

$$E = \frac{1}{2} m v^2 \quad (3)$$

Where:

E = Sound energy

m = Mass of vibrating object

v = Velocity of vibration (Vibration speed)

8. Elastic Energy

Elastic energy is a form of potential energy stored in an object when it is stretched, compressed, or deformed. When the object returns to its original shape, the stored energy is released. This type of energy follows Hooke's Law, which describes the relationship between force and deformation.

Characteristics:

- Stored in elastic materials (rubber bands, springs).
- Energy increases the more an object is stretched or compressed.
- Follows Hooke's Law:

$$F = kx \quad (4)$$

where force is proportional to the extension.

Sources of Elastic Energy:

- **Stretched rubber bands:** Store energy when pulled.
- **Compressed springs:** Store energy when squeezed.

- **Trampoline mats:** Stretch and compress when jumped on.
- **Arrows in a bow:** The bow stores elastic energy before release.
- **Bungee cords:** Stretch and recoil to release energy.

Examples of Elastic Energy :

- A stretched bowstring (elastic energy → kinetic energy when released).
- A compressed spring in a toy car (stores energy, then releases it to propel the car).
- A catapult (elastic energy launches objects).
- Bouncing a basketball (elastic potential energy converts to kinetic energy).

Formula for Elastic Potential Energy:

$$U = \frac{1}{2} k x^2 \quad (5)$$

Where:

U = Elastic potential energy (Joules)

k = Spring constant (N/m)

x = Displacement from the equilibrium position (meters)

III. Conservation and transformation of energy:

Energy is conserved: it cannot be created or suppressed; it can be transformed. For example, in the collision of two billiard balls, the initial kinetic energy of the two balls is equal to the kinetic energy of the two balls after the collision. In any energy transformation, the energy before transformation is equal to that after transformation.

Energy can be transferred according to three principles: in the form of work, heat, or radiation. A crane can lift a load of mass m to a height h by exerting an upward vertical force (opposite to gravity). it provides work: $m \cdot g \cdot h$.

When water is heated in a pan using a gas stove, the air-gas mixture burns providing energy, which it transfers to the pan and water which heat up. , but also towards the ambient environment.

The Sun transmits energy to us by radiation (1 kW/m^2). Transfer by radiation occurs whenever we are in the presence of waves (light, ultraviolet, X, gamma rays). All systems lose energy through radiation: the human body thus loses 50% of its energy.

The same effect can be obtained by these three methods: a skin burn can be caused by: - contact with a hot body (transfer in the form of heat) - rapid friction along a rope (transfer in the form of work) - prolonged exposure to the Sun (transfer by radiation) Energy can be transformed, but not just any way.

The following transformations can be made:

Energy can be transformed from one form to another based on physical principles. Below are some common energy transformations:

1. Electrical Energy → Mechanical Energy

Example: An electric motor converts electrical energy into mechanical motion, which powers machines like fans, pumps, and electric vehicles.

2. Chemical Energy → Thermal Energy

Example: Burning fuel (gasoline, wood, or coal) releases heat energy.

3. Chemical Energy → Electrical Energy

Example: A battery converts stored chemical energy into electrical energy, which powers devices like phones and flashlights.

4. Thermal Energy → Mechanical Energy

Example: A steam engine uses heat to produce motion. The heat turns water into steam, which expands and moves a piston.

5. Nuclear Energy → Thermal Energy → Electrical Energy

Example: In a nuclear power plant, atomic reactions release heat, which generates steam to spin a turbine and produce electricity.

6. Radiant (Light) Energy → Chemical Energy

Example: Photosynthesis converts sunlight into stored chemical energy in plants.

7. Mechanical Energy → Electrical Energy

Example: A wind turbine or hydroelectric dam converts mechanical motion into electricity.

8. Electrical Energy → Light Energy

Example: A **light bulb** converts electricity into light and heat.

9. Sound Energy → Electrical Energy → Sound Energy

Example: A **microphone** converts sound waves into electrical signals, which can be amplified and played back as sound through a speaker.

10. mechanical energy -> mechanical energy

Example: transmission (gearbox)

Certain transformations are impossible to date:

we do not know how to transform chemical energy contained in coal directly into electrical energy.

We have to use thermal energy. Burning coal provides heat that is used to create pressurized water

vapor, which powers a gas turbine that turns an electric generator. Similarly, the human body needs chemical energy (food), which it uses in electrical form to activate muscles.

In any transformation, energy is degraded by providing heat. The turbine, the generator, are moving systems, which undergo friction, therefore a loss, transformed into heat. A motor vehicle experiences external friction from the air and internal friction from its mechanisms. The wheels, the engine, the transmission components heat up. Not all energy is used to provide the work requested.

Chapter 2: Energy management: production, transformation, transport and storage

I. Definition of energy management

Energy management is the process of monitoring, controlling, and optimizing energy use to improve efficiency, reduce costs, and minimize environmental impact. It applies to industries, businesses, and households and involves strategies such as:

Components of Energy Management

- 1. Energy Monitoring and Auditing:** Tracking energy consumption patterns and identifying inefficiencies.
- 2. Energy Efficiency Improvements:** Upgrading equipment, optimizing processes, and using energy-efficient technologies.
- 3. Demand Management:** Reducing peak demand and shifting energy usage to off-peak hours.
- 4. Renewable Energy Integration:** Incorporating solar, wind, or other renewable sources.
- 5. Automation and Smart Technologies:** Implementing IoT sensors, AI, and energy management systems (EMS) for real-time optimization.
- 6. Behavioral & Policy Changes:** Encouraging energy-conscious practices and implementing policies to enforce sustainability.
- 7. Cost & Carbon Footprint Reduction:** Lowering energy bills and reducing greenhouse gas emissions.

II. Production of Energy: Overview and Methods

Energy production refers to the generation of power from various sources to meet industrial, commercial, and residential needs. It can be categorized into renewable and non-renewable sources. Presentation and operating principle: The main modes of electric energy production: thermal power plants:

- flame (62.5% of world production)
- nuclear (17.5% of world production)
- renewable energies: hydraulic power stations, solar, geothermal, wind turbine, tidal turbine... (20% of world production).

1. Non-Renewable Energy Sources

These sources rely on finite resources that take millions of years to form.

- **Fossil Fuels** (Coal, Oil, Natural Gas)
 - **Process:** Burning fuels to produce heat, which generates steam to drive turbines.
 - **Advantages:** High energy output, widely available.

- **Disadvantages:** High carbon emissions, environmental degradation, finite supply.
- **Nuclear Energy**
- **Process:** Nuclear fission (splitting uranium/plutonium atoms) releases heat, producing steam to spin turbines.
- **Advantages:** Low greenhouse gas emissions, high energy yield.
- **Disadvantages:** Radioactive waste, high initial cost, risk of accidents.

Impacts on the environment:

Thermal power plants are means of producing very dirty energy. They release a lot of gases into the atmosphere (mainly carbon dioxide CO₂). - They are responsible for acid rain and air pollution.

Nuclear power plants do not emit greenhouse gases. They produce radioactive waste. The storage of radioactive waste poses a big problem for the environment.

2. Renewable Energy Sources

Definition of renewable energy:

Renewable energies come from inexhaustible sources (energy from the Sun, wind, geothermal energy, tides) or renewable on the scale of human life if the resource is well managed (wood, plants). It is a clean renewable energy that emits no pollution. The only negative aspect would be the aesthetic aspect. It is essential to develop renewable energies in order to take the stage of energies whose reserves are running out.

Renewable energies are divided into 5 categories: hydraulic energy (92.5% of electricity from renewable energies), wind energy (0.5%), biomass energy (5.5%), solar energy (0.05%) and geothermal energy (1.5%). These sources are naturally replenished and more sustainable.

➤ **Solar Energy**

Presentation and operating principle: solar energy is harnessed from the sun's radiation and converted into usable electricity or heat. The two main technologies used are photovoltaic (PV) systems and solar thermal systems

Impacts on the environment: It is a clean renewable energy that emits no pollution.

- **Process:** Photovoltaic cells (solar panels) convert sunlight into electricity.
- **Advantages:** Unlimited resource, eco-friendly, low maintenance.
- **Disadvantages:** Weather-dependent, requires space.

➤ **Wind Energy**

Presentation and operating principle: A wind turbine uses energy from the wind. The mechanical energy of the wind turns the blades that make up the turbine of the wind turbine, which also drives

an alternator. Part of the mechanical energy of rotation of the blades is thus converted by the alternator into electrical energy.

Impacts on the environment: It is a clean renewable energy that emits no pollution. The only negative aspect would be the aesthetic aspect.

- **Process:** Wind turns turbine blades, which generate electricity through a generator.
- **Advantages:** No emissions, cost-effective long-term.
- **Disadvantages:** Intermittent, requires large areas.

➤ **Hydropower (Hydroelectric Energy)**

Presentation and operating principle: In a hydraulic power plant, water acquires kinetic energy which turns a turbine. The turbine drives the alternator. The latter converts part of the mechanical rotational energy of the turbine into electrical energy.

Impact on the environment: A hydraulic power plant produces electrical energy without producing greenhouse gases. It is therefore clean energy.

- **Process:** Flowing water spins turbines connected to generators.
- **Advantages:** Reliable, efficient, no direct emissions.
- **Disadvantages:** Affects ecosystems, high initial cost.

➤ **Biomass Energy**

Presentation and operating principle: Biomass energy is a renewable energy source derived from organic materials, such as plants, agricultural waste, wood, and animal residues. These materials are converted into energy through various processes, providing heat, electricity, or biofuels. Biomass is a key component of sustainable energy systems, as it utilizes waste products and reduces reliance on fossil fuels.

Impacts on the environment: It is a clean renewable energy that emits no pollution.

- **Process:** Organic materials (wood, waste, crops) are burned or processed into biofuels.
- **Advantages:** Utilizes waste, reduces reliance on fossil fuels.
- **Disadvantages:** Can contribute to deforestation, emits CO₂.

➤ **Geothermal Energy**

- **Process:** Heat from the Earth's core is used to generate steam and drive turbines.
- **Advantages:** Constant energy source, low emissions.
- **Disadvantages:** Location-dependent, expensive initial investment.

Impacts on the environment: It is a clean renewable energy that emits no pollution.

3. Emerging Energy Technologies

- **Fusion Energy:** Theoretical process of fusing atomic nuclei (like the sun), offering unlimited clean energy.
- **Hydrogen Fuel Cells:** Converts hydrogen into electricity, emitting only water vapor.

Energy diagrams.

Energy diagram of Hydropower (Figure 1)

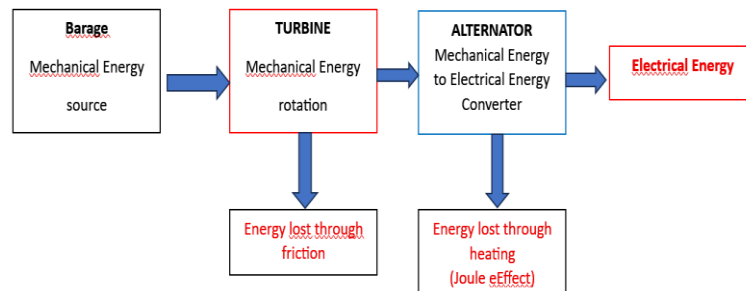

Figure 1. Energy diagram of Hydropower

Energy diagram of wind turbine (Figure 2)

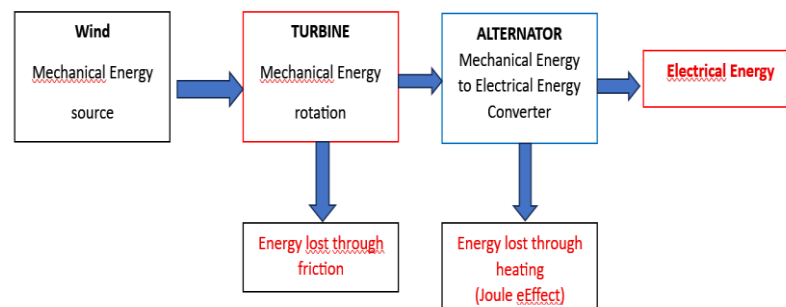

Figure 2. Energy diagram of wind turbine

III. Energy Transport

Energy transport is the movement of energy from its source to where it is needed. This includes fuels, electricity, water for hydropower, and heat. Below is a breakdown of how each type of energy is transported:

1. Transportation of Fuels

Energy transport plays a crucial role in global energy distribution. The efficiency of transport methods impacts energy costs, reliability, and environmental sustainability. Fuels like coal, oil, natural gas, and biomass must be transported from extraction sites to power plants, refineries, and consumers.

Main Transport Methods:

- Pipelines: Used for oil, natural gas, and biofuels.

- Tankers and Ships: Transport crude oil, liquefied natural gas (LNG), and refined petroleum across oceans.
- Rail Transport: Common for coal, oil, and biofuels.
- Trucks: Road Transport: Used for local delivery of gasoline, diesel, and propane.
- Conveyor Belts: Used in coal-fired power plants to transport coal.

Challenges: Environmental risks (oil spills, gas leaks), infrastructure costs, geopolitical issues.

2. Transport of Electrical Energy

Electricity is transported via power grids from generation plants to industries and homes.

Components:

- Power Plants: Generate electricity from fossil fuels, nuclear, hydro, solar, or wind.
- Transmission Lines (High Voltage) : Carry electricity over long distances with minimal loss.
- Substations: Convert high voltage to lower voltage for local distribution.
- Distribution Lines (Low Voltage): Deliver electricity to homes and businesses.

Methods of Transmission:

- Overhead Power Lines: High-voltage transmission using steel towers and cables.
- Underground Cables: Used in cities for reliability and aesthetics but more expensive.
- HVDC (High-Voltage Direct Current): Reduces losses over long distances.

Challenges: Energy losses, infrastructure maintenance, grid stability.

3. Transport of Hydraulic Energy

Hydraulic energy (from moving water) is transported in different ways:

Types of Transport:

- Dams and Aqueducts : Transport water for hydroelectric plants or irrigation.
- Pumped Storage Systems: Store excess electricity by pumping water to a higher reservoir and releasing it later to generate power.

Challenges: Water availability, environmental impact, infrastructure costs.

4. Transport of Thermal Energy

Thermal energy (heat) is transported for industrial, heating, and power generation purposes.

Methods of Heat Transport:

- Steam Pipelines: Transport steam from power plants to industrial sites (e.g., cogeneration plants).

- District Heating Systems: Distribute hot water or steam to multiple buildings in cities.
- Heat Exchangers and Thermal Storage: Store and transfer heat efficiently.
- Thermal Fluids (Molten Salt, Oil): Used in solar thermal power plants to store and move heat.

Challenges: Heat loss over distance, infrastructure costs, efficiency.

IV. Storage of Electrical Energy:

Electrical energy storage is essential for balancing supply and demand, integrating renewable energy sources, and ensuring a stable and reliable power grid. Various technologies are used to store electrical energy, each with its own advantages and applications.

1. Electrochemical Storage of Electrical Energy

- **Process:** Converts electrical energy into chemical energy and releases it when needed.
- **Examples:**
 - Lithium-ion batteries (Used in electric vehicles, portable devices, and grid storage)
 - Lead-acid batteries (Used in cars and backup power systems)
 - Sodium-ion and solid-state batteries (Emerging technologies for safer and longer-lasting storage)
 - Flow batteries (Scalable for large-scale energy storage)
- **Advantages:** Efficient, scalable, rechargeable.
- **Disadvantages:** Limited lifespan, environmental concerns over materials like lithium and cobalt.

2. Electrostatic Storage of Electrical Energy (Capacitors and Supercapacitors)

- **Process:** Stores energy in an electric field between two conductive plates.
- **Examples:**
 - Capacitors (Used in electronics for short-term energy storage)
 - Supercapacitors (Fast-charging, high-power applications, but lower energy capacity than batteries)
- **Advantages:** Rapid charge/discharge cycles, long lifespan.
- **Disadvantages:** Low energy density (not suitable for long-term storage).

3. Kinetic Storage of Energy (Flywheels)

- **Process:** Converts electrical energy into rotational energy by spinning a rotor; when energy is needed, the rotor slows down, converting motion back into electricity.

- **Examples:**

- Flywheel energy storage systems (Used in power grids, trains, and uninterruptible power supplies)

- **Advantages:** High efficiency, long lifespan, fast response time.

- **Disadvantages:** High cost, mechanical wear, energy loss due to friction.

4. Energy Storage in Hydraulic Form (Pumped Hydro Storage)

- **Process:** Uses excess electricity to pump water to a higher reservoir; when energy is needed, water flows down through turbines to generate electricity.

- **Example:**

- Pumped Hydro Storage

- **Advantages:** High efficiency (~80%), large-scale storage, long lifespan.

- **Disadvantages:** Requires specific geography (hilly/mountainous areas), expensive infrastructure.

5. Energy Storage in the Form of Compressed Air (CAES – Compressed Air Energy Storage)

- **Process:** Uses electricity to compress air into underground storage; when needed, the air is released to drive turbines and generate electricity.

- **Example:**

- Large-scale CAES plants (Used as grid backup storage)

- **Advantages:** Large-scale storage, long lifespan.

- **Disadvantages:** Energy loss due to heat dissipation, requires underground storage.

6. Energy Storage in the Form of Heat (Thermal Energy Storage: TES)

- **Process:** Stores excess energy as heat in materials and releases it when needed.

- **Examples:**

- Molten salt storage (Used in solar thermal power plants)

- Phase Change Materials (PCMs) (Used in buildings for temperature regulation)

- Hot water storage (For residential and industrial heating)

- **Advantages:** Cost-effective, long storage duration.

- **Disadvantages:** Energy conversion losses, location-dependent.

7. Energy Storage in the Form of Hydrogen (Hydrogen Energy Storage: HES)

- **Process:** Uses excess electricity to split water into hydrogen and oxygen (electrolysis); the hydrogen is stored and later converted back into electricity via fuel cells or combustion.
- **Examples:**
 - Green hydrogen storage (Produced using renewable energy)
 - Hydrogen fuel cells (Used in vehicles, industries, and power backup)
- **Advantages:** High energy density, long-term storage potential, can be transported.
- **Disadvantages:** High cost, energy loss during conversion, infrastructure challenges.

Each energy storage method has specific applications based on efficiency, duration, cost, and scalability. Future advancements in battery technology, hydrogen storage, and thermal energy storage will help create more sustainable and efficient energy systems.

Chapter 3: Energy Transport

Energy transport refers to the movement of energy from one location to another, which is a fundamental process in both natural and engineered systems. Energy can exist in various forms, such as thermal (heat), mechanical, electrical, chemical, or nuclear energy, and its transport is essential for sustaining life, powering technologies, and driving natural processes.

I. Fuel Transport

Fuel transport refers to the movement of fuels from their source (e.g., extraction sites, refineries, or production facilities) to end-users, such as power plants, industries, vehicles, or households. Fuels are essential for powering modern economies, and their efficient and safe transport is critical for energy security, economic stability, and environmental sustainability.

1. Pipeline transport mode

Pipeline transport (Figure 1) is a mode of transporting fluid materials through a network of pipelines. However, the products usually referred to as "pipeline transport" are: oil and other liquid hydrocarbons, natural gas and other combustible gases, as well as certain chemical products. Depending on the product being transported, pipelines have specific names: gas pipeline, oil pipeline.

Oil and Gas Pipeline Transport

Oil and gas pipeline transport is one of the most efficient and widely used methods for moving petroleum products and natural gas over long distances. It plays a crucial role in the global energy supply chain.

Although underwater techniques exist, maritime transport by tanker or liquefied natural gas carrier is more economical for crossing large maritime distances.

The pipeline transport of these hydrocarbons mainly uses steel pipes, welded together and coated to better withstand corrosion and chemical or mechanical damage.

The fluid transported in the pipelines generally moves under pressure, at speeds ranging from 1 to 6 m/s. The pressure and flow rate (or speed) are generated by centrifugal pumps (for liquids) or compressors (for gases).

Oil pipelines often transport several types of hydrocarbons, in sequences called "trains" or "batches". At the interface between two trains, a partial mixture of products is created. The plug (mixing zone called "interface" (contamination)) is removed and treated upon arrival at the receiving station.

Gas pipeline systems, on the other hand, usually transport gaseous fluids whose composition remains stable over time.



Figure 1. Pipeline transport mode

Components of pipeline transport networks

Pipeline transport networks consist of pipeline sections and related structures that perform specific functions:

- **Injection or departure stations** are the network entry points. Depending on their configuration and geographical location, these can be landfall stations, terminals, inlet stations;
- **Compressor stations** (for gases) or **pumping stations** (for liquids) are distributed regularly along the transport networks to maintain the speed of the fluid in the pipelines by pressure;
- **Delivery stations** allow the transported material to be made available to intermediate or final recipients;
- **Sectionalizing stations** make it possible to isolate a pipeline section in order to ensure its maintenance or to limit the harmful consequences in the event of a leak. These stations are sometimes equipped with valves to introduce and receive scraper pigs, intended to check the various parameters of pipeline integrity: geometry, cleanliness, metal loss, cracking, etc.;

The distance between two consecutive sectionalizing stations depends on the applicable regulations, according to the fluid transported and the country concerned. The distance between two consecutive cut-off (or half-cut-off) stations ranges from ten kilometers for short spurs or special points, to a few hundred kilometers for major transit pipelines;

- **Pressure regulating or control stations** are used to reduce the pressure of the downstream fluid. These stations are often associated with delivery stations. They can also separate network sections operating at different pressures;
- **Arrival stations** mark the end of a transport network. This can be a storage reservoir or the beginning of a downstream transport or distribution network.

Advantages of Pipeline Transport:**1. Efficiency:**

Pipelines can transport large volumes of materials continuously, with minimal energy consumption compared to other modes like trucks or trains.

2. Cost-Effective:

Once constructed, pipelines have low operational costs and can transport materials over long distances at a lower cost per unit than other methods.

3. Reliability:

Pipelines are less affected by weather conditions or traffic disruptions, ensuring a steady and reliable supply.

4. Safety:

Pipelines are generally safer than other transport methods, with fewer accidents and spills compared to road or rail transport.

5. Environmental Benefits:

- Pipelines produce fewer greenhouse gas emissions per unit of material transported compared to trucks or ships.
- They reduce road congestion and the risk of accidents involving fuel tankers.

Challenges of Pipeline Transport:**1. High Initial Investment:**

Building pipelines requires significant upfront capital investment and long construction timelines.

2. Environmental Concerns:

- Pipeline leaks or spills can cause severe environmental damage, particularly in sensitive ecosystems.
- Example: The 2010 Kalamazoo River oil spill in Michigan, USA.

3. Geopolitical Risks:

- Cross-border pipelines can be affected by political tensions or conflicts between countries.
- Example: Disputes over the Nord Stream 2 pipeline between Russia and Europe.

4. Land Use and Rights-of-Way:

Constructing pipelines often requires acquiring land rights, which can lead to conflicts with landowners or indigenous communities.

5. Maintenance and Monitoring:

Pipelines require regular maintenance and advanced monitoring systems to prevent leaks, corrosion, or other failures.

Applications of Pipeline Transport:**1. Oil and Gas Industry:**

- Transporting crude oil from oil fields to refineries and refined products to distribution centers.
- Transporting natural gas from production sites to power plants, industries, and homes.

2. Water Supply:

Transporting water for drinking, irrigation, or industrial use in arid regions or urban areas.

3. Mining and Industrial Use:

Transporting slurries of minerals, ores, or waste materials in mining operations.

4. Emerging Applications:

- Transporting hydrogen for use in clean energy systems.
- Transporting carbon dioxide (CO₂) for carbon capture and storage (CCS) projects.

Future of Pipeline Transport:**1. Hydrogen Pipelines:**

- As the world transitions to clean energy, pipelines will play a key role in transporting hydrogen, a zero-emission fuel.
- Existing natural gas pipelines may be repurposed for hydrogen transport.

2. Carbon Capture and Storage (CCS):

Pipelines will be essential for transporting captured CO₂ to storage sites, helping reduce greenhouse gas emissions.

3. Digitalization and Smart Pipelines:

Advanced technologies like IoT sensors, AI, and machine learning will improve pipeline monitoring, leak detection, and predictive maintenance.

4. Expansion in Developing Countries:

As energy demand grows in developing regions, new pipeline networks will be built to transport oil, gas, and water.

2. Road transport mode

The transport of oil by truck is mainly reserved for refined products. For example, it is used to supply service stations. Trucks have several compartments in their tanks to separate the different types of fuel and avoid multiplying trips. The truck also remains the only means of transport that can reach any point in the territory thanks to the many roads.



Figure 1. Transport by truck

Types of Energy Transported by Road:

1. Liquid Fuels:

- Gasoline and Diesel: Transported in tanker trucks from refineries or storage terminals to gas stations.
- Heating Oil: Delivered to homes and businesses for heating purposes.
- Aviation Fuel: Transported to airports for use in aircraft.
- Biofuels: Ethanol and biodiesel are transported to blending facilities or directly to fuel stations.

2. Gaseous Fuels:

- Liquefied Petroleum Gas (LPG): Transported in pressurized tankers for use in heating, cooking, and vehicles.
- Compressed Natural Gas (CNG): Transported in high-pressure cylinders for use in vehicles and industrial applications.
- Liquefied Natural Gas (LNG): Transported in cryogenic tankers for use in heavy-duty vehicles, ships, and industrial processes.

3. Solid Fuels:

- Coal: Transported in trucks from mines to power plants or industrial facilities, especially in regions without rail access.
- Biomass: Wood chips, pellets, and other biomass materials are transported for use in heating or power generation.

4. Alternative Energy Carriers:

- Hydrogen: Transported as compressed gas or in liquid form (cryogenic tankers) for use in fuel cells and industrial processes.
- Batteries: Transported for electric vehicles (EVs) and energy storage systems.
- Electricity (Indirect): While electricity itself is not transported by road, the components of energy systems (e.g., transformers, solar panels, wind turbines) are often delivered by road.

Vehicles Used for Road Transport of Energy:**1. Tanker Trucks:**

- Designed to transport liquid fuels like gasoline, diesel, and LPG.
- Equipped with safety features to prevent spills and leaks.

2. Cryogenic Tankers:

- Used for transporting liquefied gases like LNG and liquid hydrogen.
- Insulated to maintain extremely low temperatures.

3. Flatbed Trucks:

- Used for transporting heavy or oversized energy-related equipment, such as wind turbine components or transformers.

4. Delivery Vans:

Used for small-scale deliveries, such as LPG cylinders to households or biofuels to local stations.

5. Specialized Vehicles:

Hydrogen fuel cell trucks and electric trucks are emerging as sustainable alternatives for energy transport.

Advantages of Road Transport for Energy:**1. Flexibility and Accessibility:**

- Road transport can reach remote or rural areas where other modes (e.g., pipelines or rail) are not available.
- Ideal for last-mile delivery to end-users like gas stations, homes, and small businesses.

2. Quick Deployment:

Road transport does not require extensive infrastructure like pipelines or railways, making it faster to deploy.

3. Versatility:

Can transport a wide range of energy resources, from liquid fuels to gaseous fuels and solid fuels.

4. Emergency Response:

- Road transport is essential for delivering fuel during emergencies, such as natural disasters or supply disruptions.

5. Cost-Effective for Short Distances:

For short to medium distances, road transport is often more economical than rail or air.

Challenges of Road Transport for Energy:**1. Environmental Impact:**

- Road transport relies heavily on fossil fuels, contributing to greenhouse gas emissions and air pollution.
- Spills or accidents during fuel transport can cause environmental damage.

2. Safety Risks:

Transporting flammable or hazardous materials like gasoline, LPG, or hydrogen poses safety risks, including fires or explosions.

3. Traffic Congestion:

Urban areas often face traffic jams, leading to delays and increased fuel consumption.

4. High Operating Costs:

Fuel, maintenance, and labor costs can make road transport expensive, especially for long distances.

5. Limited Capacity:

Compared to pipelines or rail, road transport has limited capacity, making it less efficient for bulk energy transport.

Applications of Road Transport in the Energy Sector:**1. Fuel Distribution:**

- Delivering gasoline, diesel, and LPG to gas stations and households.
- Transporting aviation fuel to airports.

2. Renewable Energy:

- Delivering biomass for bioenergy plants.
- Transporting components for solar panels, wind turbines, and energy storage systems.

3. Emerging Energy Carriers:

- Transporting hydrogen for use in fuel cell vehicles and industrial processes.
- Delivering batteries for electric vehicles and grid storage.

4. Emergency Fuel Supply:

Providing fuel to disaster-affected areas or during supply chain disruptions.

5. Industrial Use:

Delivering fuels like natural gas, coal, and biomass to factories and power plants.

Future of Road Transport for Energy:**1. Electrification of Transport:**

- Electric trucks and vans are being developed for sustainable energy transport, reducing reliance on fossil fuels.
- Example: Tesla Semi, an electric truck designed for freight transport.

2. Hydrogen Fuel Cell Vehicles:

- Hydrogen-powered trucks are emerging as a zero-emission alternative for transporting energy resources.
- Example: Hyundai XCIENT Fuel Cell truck.

3. Autonomous Vehicles:

Self-driving trucks could improve efficiency and safety in energy transport, especially for long-haul routes.

4. Green Fuels:

Adoption of biofuels, synthetic fuels, and hydrogen for powering transport vehicles.

5. Smart Logistics:

Use of Internet of Things (IoT), Artificial Intelligence(AI), and data analytics to optimize routes, reduce fuel consumption, and improve delivery efficiency.

6. Decentralized Energy Systems:

Road transport will play a key role in delivering energy resources to decentralized systems, such as microgrids and off-grid communities.

3. Rail transport mode

Today, the oil pipeline network is not sufficient to transport all the oil produced. Tanker wagons (Figure 3) are therefore used which sometimes transport oil pipelines, thus forming a "virtual and mobile pipeline". The advantage of the train is to be more mobile, to be able to use all the existing

railways and to adapt to the demand by adding additional wagons if necessary. This solution is still considered dangerous thanks to accidents. Derailments can lead to heavy losses and cause fires and ecological risks.



Figure 3. Transport by rail

Types of Energy Transported by Rail:

1. Solid Fuels:

- Coal: Rail is the primary mode of transport for coal from mines to power plants or export terminals.
- Biomass: Wood pellets and other biomass materials are transported for use in bioenergy plants.

2. Liquid Fuels:

- Crude Oil: Transported in tank cars from oil fields to refineries.
- Refined Petroleum Products: Gasoline, diesel, and jet fuel are transported to distribution centers.
- Biofuels: Ethanol and biodiesel are transported for blending with conventional fuels.

3. Gaseous Fuels:

- Liquefied Natural Gas (LNG): Transported in specialized cryogenic tank cars.
- Compressed Natural Gas (CNG): Transported in high-pressure containers.

4. Energy Equipment:

- Wind Turbine Components: Blades, towers, and nacelles are transported to wind farm sites.
- Solar Panels and Transformers: Delivered to solar farms and power substations.
- Nuclear Fuel: Transported in secure containers for use in nuclear power plants.

Advantages of Rail Transport for Energy:**1. High Capacity:**

- Rail transport can move large volumes of energy resources in a single trip, making it ideal for bulk materials like coal and crude oil.

2. Cost-Effective for Long Distances:

- Rail is more economical than road transport for long-distance energy transport, especially for heavy or bulk cargo.

3. Energy Efficiency:

Trains are more fuel-efficient than trucks, reducing the carbon footprint of energy transport.

4. Reduced Traffic Congestion:

Rail transport reduces the number of trucks on the road, easing traffic congestion and lowering road maintenance costs.

5. Safety:

Rail transport is generally safer for hazardous materials like crude oil and LNG, as it reduces the risk of accidents compared to road transport.

6. Reliability:

Rail networks are less affected by weather conditions compared to road or air transport, ensuring consistent delivery.

Challenges of Rail Transport for Energy:**1. Limited Flexibility:**

Rail transport requires fixed infrastructure (tracks and terminals), making it less flexible than road transport for last-mile delivery.

2. High Initial Investment:

Building and maintaining rail infrastructure is expensive, requiring significant capital investment.

3. Dependency on Infrastructure:

Rail transport is limited to areas with rail networks, which may not be available in remote or underdeveloped regions.

4. Environmental Impact:

- While rail is more efficient than road, it still relies on diesel locomotives in many regions, contributing to emissions.

- Transporting fossil fuels like coal and crude oil supports carbon-intensive energy systems.

5. Regulatory and Logistical Challenges:

Rail transport is subject to strict regulations, especially for hazardous materials, which can increase costs and complexity.

Components of Rail Transport for Energy:

1. Freight Trains:

Specialized trains for transporting energy resources, such as coal trains, oil tankers, and LNG carriers.

2. Railcars:

- **Hopper Cars:** Used for transporting bulk materials like coal and biomass.
- **Tank Cars:** Designed for liquid fuels like crude oil, gasoline, and ethanol.
- **Cryogenic Tank Cars:** Used for transporting LNG and other liquefied gases.
- **Flatbed Cars:** Used for transporting oversized equipment like wind turbine components.

3. Rail Infrastructure:

Tracks, terminals, and loading/unloading facilities are essential for efficient rail transport.

4. Locomotives:

Diesel-electric or electric locomotives power freight trains. Efforts are underway to develop hydrogen-powered and battery-electric locomotives for cleaner energy transport.

5. Safety Systems:

Advanced monitoring systems, derailment prevention technologies, and secure containers for hazardous materials ensure safe transport.

Applications of Rail Transport in the Energy Sector:

1. Coal Transport:

Rail is the primary mode for transporting coal from mines to power plants, especially in countries like the United States, China, and India.

2. Oil and Gas Transport:

- Crude oil is transported from oil fields to refineries, while refined products like gasoline and diesel are moved to distribution centers.

- Liquefied Natural Gas (LNG) is transported from liquefaction plants to regasification terminals or end-users.

3. Renewable Energy:

Rail transport is used to deliver wind turbine components, solar panels, and other equipment to renewable energy project sites.

4. Nuclear Energy:

Rail is used to transport nuclear fuel rods and other materials for nuclear power plants.

5. Bioenergy:

Biomass materials like wood pellets are transported to bioenergy plants for electricity generation or heating.

Future of Rail Transport for Energy:

1. Electrification and Green Locomotives:

- Transitioning from diesel to electric, hydrogen-powered, or battery-electric locomotives to reduce emissions.
- Example: Alstom's hydrogen-powered Coradia iLint train.

2. Digitalization and Automation:

- Use of IoT, AI, and predictive analytics to optimize rail operations, reduce fuel consumption, and improve safety.

3. Increased Use for Renewable Energy:

- Rail transport will play a key role in delivering components for wind, solar, and energy storage projects as renewable energy capacity grows.

4. Energy Transition:

Rail transport will adapt to new energy carriers, such as hydrogen and biofuels, as the world shifts away from fossil fuels.

5. Infrastructure Expansion:

Developing new rail networks and upgrading existing ones to support growing energy transport needs.

Characteristics of oil tankers

The transport capacity of oil tankers is expressed in "deadweight tonnage" (dwt). This corresponds to their maximum load.

The most common oil tankers currently in operation have a capacity of:

- Panamax capable of carrying between 50,000 and 79,999 dwt. This capacity corresponds to the limit imposed on oil tankers to transit the Panama Canal;
- Aframax between 80,000 and 124,999 dwt (maximum capacity for ships with an AFRA gauge system, for "Average Freight Rate Assessment");
- Suezmax from 125,000 to 199,999 dwt;
- VLCC (for "Very Large Crude Carriers") from 200,000 dwt up to 349,999 dwt in the case of double-hulled vessels (up to 319,999 dwt in the case of single-hull vessels);
- ULCC (for "Ultra Large Crude Carriers") above 320,000 dwt in the case of single-hull vessels and above 350,000 dwt in the case of double-hull vessels.

The largest oil tankers currently in operation have a capacity of 441,560 dwt. The average speed of a 250,000-tonne oil tanker is about 15 knots, which is nearly 28 km/h.

4. Maritime transport mode

Oil can be transported by oil tankers, also called "tankers" or "supertankers" (Figure 4) for the largest ones. Oil tankers have different names depending on the type of products they carry (crude oil or refined products) and their onboard capacity. The size of the ships (and therefore their transport capacity) is also limited according to the transit points used (more or less wide).



Figure 4. Maritime Transport

Types of Energy Transported by Maritime Transport:

1. Liquid Fuels:

- **Crude Oil:** Transported in large tankers from oil-producing regions (e.g., the Middle East) to refineries worldwide.
- **Refined Petroleum Products:** Gasoline, diesel, and jet fuel are transported to distribution centers and end-users.

- **Liquefied Natural Gas (LNG):** Transported in specialized cryogenic tankers from liquefaction plants to regasification terminals.
- **Liquefied Petroleum Gas (LPG):** Transported in pressurized tankers for use in heating, cooking, and industrial applications.

2. Solid Fuels:

- **Coal:** Transported in bulk carriers from coal-producing countries (e.g., Australia, Indonesia) to power plants and industrial facilities.
- **Biomass:** Wood pellets and other biomass materials are transported for use in bioenergy plants.

3. Alternative Energy Carriers:

- **Hydrogen:** Emerging as a future energy carrier, hydrogen can be transported as liquefied hydrogen or in chemical carriers like ammonia.
- **Ammonia:** Used as a hydrogen carrier and fuel for ships, ammonia is transported in specialized tankers.

4. Energy Equipment:

- **Wind Turbine Components:** Blades, towers, and nacelles are transported to offshore wind farm sites.
- **Oil and Gas Equipment:** Drilling rigs, pipelines, and other infrastructure components are transported to offshore oil and gas fields.

Advantages of Maritime Transport for Energy:

1. High Capacity:

Ships can carry massive quantities of energy resources, making maritime transport ideal for bulk materials like crude oil, coal, and LNG.

2. Cost-Effective for Long Distances:

Maritime transport is the most economical mode for long-distance and international energy trade, especially for large volumes.

3. Global Reach:

Ships can access almost any coastal region, enabling energy trade between distant countries and continents.

4. Energy Efficiency:

Ships are more fuel-efficient per ton-mile compared to road or rail transport, reducing the carbon footprint of energy transport.

5. Reduced Infrastructure Dependency:

Unlike pipelines or rail, maritime transport does not require fixed infrastructure between origin and destination, making it flexible for international trade.

6. Versatility:

Maritime transport can handle a wide range of energy resources, from liquid fuels to solid fuels and alternative energy carriers.

Challenges of Maritime Transport for Energy:**1. Environmental Impact:**

- Ships traditionally rely on heavy fuel oil, which emits greenhouse gases, sulfur oxides (SO_x), and nitrogen oxides (NO_x), contributing to air pollution and climate change.
- Oil spills and accidents can cause severe environmental damage to marine ecosystems.

2. Regulatory Compliance:

The International Maritime Organization (IMO) enforces strict regulations on emissions, fuel quality, and safety, increasing operational costs.

3. Geopolitical Risks:

Maritime transport routes can be affected by political tensions, piracy, or conflicts in key chokepoints like the Strait of Hormuz or the Suez Canal.

4. Slow Speed:

Ships are slower than road, rail, or air transport, which can lead to longer delivery times.

5. Port Infrastructure:

Maritime transport requires well-equipped ports for loading, unloading, and storage, which may be lacking in some regions.

6. Safety Risks:

Transporting hazardous materials like crude oil and LNG poses risks of spills, fires, or explosions.

Components of Maritime Transport for Energy:**1. Ships:**

- **Tankers:** Used for transporting liquid fuels like crude oil, refined products, and LNG.
- **Bulk Carriers:** Used for transporting solid fuels like coal and biomass.
- **Specialized Vessels:** LNG carriers, LPG tankers, and hydrogen/ammonia carriers.

2. Ports and Terminals:

Loading and unloading facilities for energy resources, including oil terminals, LNG regasification plants, and coal ports.

3. Safety Systems:

Advanced navigation systems, double-hulled tankers, and spill response mechanisms to ensure safe transport.

4. Regulatory Frameworks:

International regulations, such as IMO's MARPOL Convention, govern emissions, safety, and environmental protection in maritime transport.

Applications of Maritime Transport in the Energy Sector:**1. Global Energy Trade:**

- Transporting crude oil from the Middle East to Asia, Europe, and the Americas.
- Shipping LNG from the United States, Qatar, and Australia to global markets.

2. Coal Transport:

Moving coal from major exporters (e.g., Australia, Indonesia) to energy-hungry regions like China and India.

3. Renewable Energy:

- Transporting wind turbine components for offshore wind farms.
- Delivering biomass materials for bioenergy plants.

4. Emerging Energy Carriers:

Transporting hydrogen and ammonia as future energy carriers.

5. Oil and Gas Exploration:

Transporting equipment and supplies to offshore oil and gas fields.

Future of Maritime Transport for Energy:**1. Decarbonization:**

- Adoption of cleaner fuels like LNG, hydrogen, and ammonia to power ships.
- Development of electric and hybrid vessels for short-distance transport.

2. Green Shipping Initiatives:

- IMO's goal to reduce greenhouse gas emissions from shipping by 50% by 2050.
- Use of wind-assisted propulsion and solar power for ships.

3. Digitalization:

Implementation of IoT, AI, and blockchain for efficient fleet management, route optimization, and cargo tracking.

4. Expansion of LNG Trade:

Growing demand for LNG as a transition fuel will increase the need for LNG carriers and infrastructure.

5. Hydrogen and Ammonia Transport:

Development of specialized vessels and infrastructure for transporting hydrogen and ammonia as clean energy carriers.

6. Port Modernization:

Upgrading ports to handle new energy carriers like hydrogen and ammonia, as well as larger vessels.

Comparison of different mode of fuel transport (Table 1)

Table 1. Comparison of different mode of fuel transport

Aspect	Maritime Transport	Road Transport	Rail Transport	Pipeline Transport
Capacity	Very High	Low to Medium	High	Very High
Cost (Long Distance)	Low	High	Medium	Medium
Environmental Impact	Medium	High	Medium	Medium
Speed	Low	High (Short Distance)	Medium	High
Flexibility	Medium	High	Medium	Low

II. Electric power transport

1. Electric power generation and transmission

The electric power (Figure 5) produced by the various power plants is transmitted at high voltage, which makes it possible to transmit high power. This voltage is then lowered for distribution at a higher or lower level depending on the power required by the end consumer.

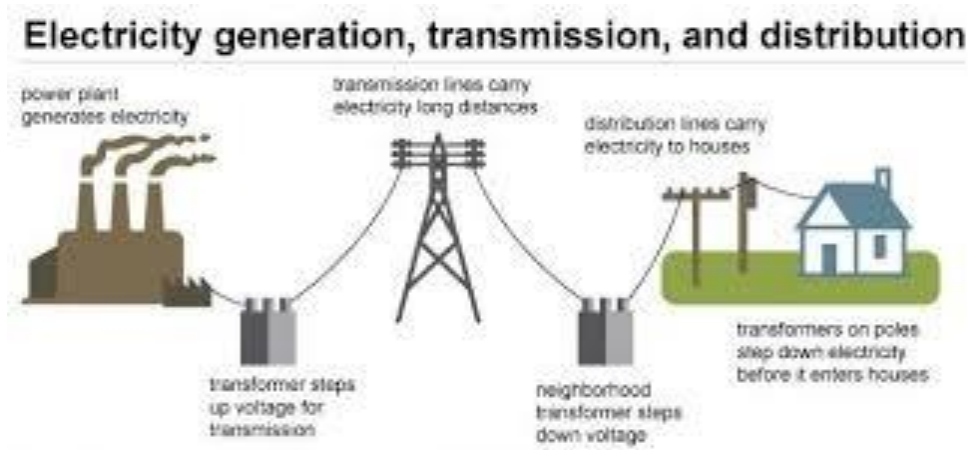

Figure 5. Electric power generation and transmission

The generation and transmission of electrical energy is most often done in three-phase alternating current (Figure 6). The energy flows through 3 conductors called phases (or line conductors).

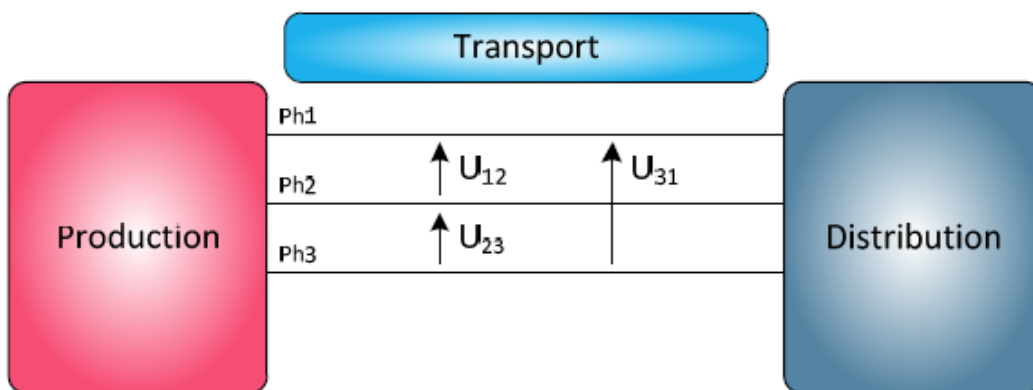

Figure 6. three-phase alternating current.

2. Voltage ranges

Electrical equipment and installations are classified into voltage ranges:

- LV (Low Voltage)
- MV (Medium Voltage) Corresponds to
- HV (High Voltage) Corresponds to the 90 kV range
- EHV (Extra High Voltage)

3. Power transmission problem

The power plants that generate electricity are located according to geographical conditions (hydro, wind, etc.), fuel supply constraints or cooling water supply (thermal power plants, etc.). As for energy consumers, they are distributed throughout the territory, and often far from major power generation plants.

The transmission and interconnection network continuously provides a link between the generating power plants and the consumption sites, knowing that electricity cannot be stored (at any given time, production equals consumption).

4. Structure of the transmission and distribution network

- **Interconnection**

All high voltage lines are interconnected, that is, they are connected by transformer substations ensuring continuity between lines at different voltage levels.

- **From production to use (Figure 7)**

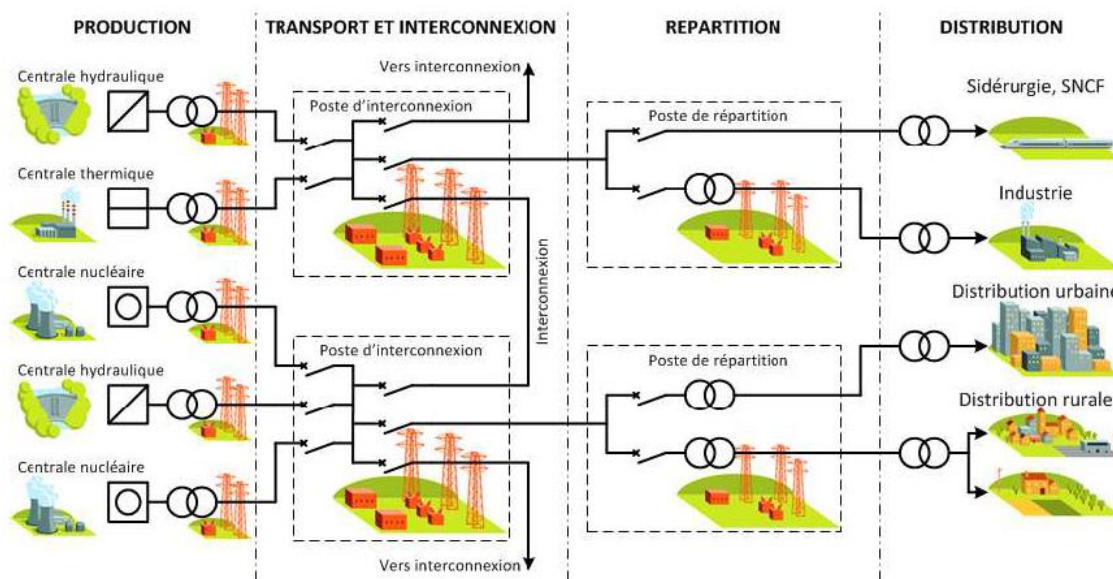

Figure 7. Structure of the transmission and distribution network

- **Production:** The most common voltage supplied by the alternators of the power plants is 20 kV.
 - Transmission and interconnection: The voltage of the power plants is increased to 225 kV for regional loops or 400 kV for national loops.
 - Distribution: At the local level, distribution is done with voltages between 63 and 150 kV.
 - Distribution: Depending on the power required by consumers, it is done between 230 V and

5. The cables

There are several types of bare overhead line conductors (Figure 8) depending on their structure and composition:

- Homogeneous conductors made of pure aluminum (AAC)
- Heterogeneous conductors made of aluminum and steel (ACSR)
- Heterogeneous conductors made of aluminum and ACS (Aluminum Clad Steel) (ACSR/AW)
- Homogeneous conductors made of aluminum alloy (AAAC)

- Heterogeneous conductors made of aluminum alloy and ACS (Aluminum Clad Steel) (AACSR/AW)
- Heterogeneous conductors made of aluminum and aluminum alloy (ACAR)

They must all achieve a balance between mechanical strength (strength) and electrical resistance (conductivity).

Aluminum conductors with steel reinforcement (ACSR) are very resistant and withstand high voltages over long spans. All-aluminum conductors (AAC), which are corrosion resistant, are ideal for harsh.



Figure 8. line conductors

6. Underground lines

For aesthetic reasons, one would be tempted to replace overhead lines with underground cables, but this poses problems:

- An underground cable behaves like a capacitor (cable core and sheath are the electrodes). For example, for a 400 kV cable, the critical distance is 45 km, beyond which the current no longer flows.
- An underground conduit is quite vulnerable and much more difficult to locate.
- An underground line costs 12 to 15 times more than an overhead line.

In practice, the cables are grouped in "clover": Underground cables behave as capacitors and require compensation by reactors over long distances.

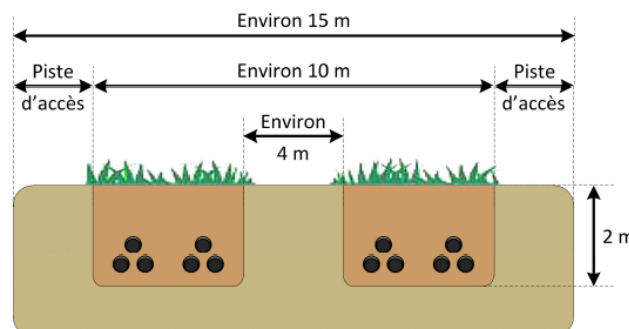

Figure 9. Underground lines

Advantages of Electric Power Transport:

Electric power transport offers numerous advantages that make it a cornerstone of modern infrastructure and energy systems. Here are the key benefits:

1. Efficient Long-Distance Energy Transfer

- High-voltage transmission lines enable electricity to be transported over long distances with minimal energy losses.
- This allows power generated in remote locations (e.g., hydroelectric dams, wind farms, or solar plants) to be delivered to urban centers where demand is high.

2. Centralized Power Generation

- Large-scale power plants can generate electricity more efficiently and cost-effectively than smaller, decentralized systems.
- Centralized generation allows for economies of scale, reducing the overall cost of electricity production.

3. Reliability and Stability

- A well-designed transmission grid ensures a stable and reliable supply of electricity, even during peak demand periods.
- Redundancy in the grid (multiple pathways for electricity to flow) helps prevent outages and ensures continuity of service.

4. Integration of Renewable Energy

- Transmission networks enable the integration of renewable energy sources (e.g., wind, solar, and hydro) into the grid, even if they are located far from consumption centers.
- This is critical for reducing greenhouse gas emissions and transitioning to a cleaner energy future.

5. Load Balancing

- Transmission systems allow for the balancing of electricity supply and demand across large geographic areas.
- Excess power generated in one region can be transported to another region experiencing higher demand.

6. Economic Benefits

- Efficient power transport reduces the cost of electricity for consumers by optimizing generation and distribution.
- It also supports economic development by providing reliable energy to industries, businesses, and households.

7. Reduced Environmental Impact

- High-voltage transmission lines are more efficient than local generation using fossil fuels, reducing overall carbon emissions.
- Transporting electricity from renewable sources to urban areas minimizes the need for fossil fuel-based power plants in populated regions.

8. Scalability

- Transmission grids can be expanded and upgraded to meet growing energy demands, making them adaptable to future needs.
- New technologies, such as HVDC (High-Voltage Direct Current) lines, enhance the scalability and efficiency of power transport.

9. Support for Distributed Energy Resources (DERs)

- Modern transmission systems can accommodate distributed energy resources, such as rooftop solar panels and small-scale wind turbines, by integrating them into the grid.
- This promotes energy independence and resilience.

10. Disaster Recovery and Resilience

- A robust transmission network can quickly reroute power in the event of natural disasters or equipment failures, minimizing downtime and ensuring critical services remain operational.

11. Global Energy Interconnection

- Advanced transmission technologies, such as HVDC and undersea cables, enable cross-border and even intercontinental electricity exchange.
- This fosters international energy cooperation and enhances energy security.

12. Technological Advancements

- Innovations like smart grids, superconductors, and energy storage systems are improving the efficiency, reliability, and sustainability of power transport.
- These advancements enable better monitoring, control, and optimization of the grid.

Challenges in Electric Power Transport:**1. Energy Losses:**

Resistance in transmission lines causes energy losses, which increase with distance. High-voltage transmission helps mitigate this issue.

2. Infrastructure Aging:

Many transmission and distribution systems are aging and require upgrades to handle modern demands and integrate renewable energy sources.

3. Renewable Energy Integration:

Renewable energy sources, such as wind and solar, are often located far from population centers, requiring new transmission infrastructure.

4. Grid Stability:

Fluctuations in supply and demand, especially with intermittent renewable energy sources, can challenge grid stability.

5. Environmental and Regulatory Concerns:

Building new transmission lines can face opposition due to environmental, land use, and regulatory issues.

Innovations in Electric Power Transport:**1. High-Voltage Direct Current (HVDC):**

HVDC systems are more efficient for long-distance power transport and are increasingly used to connect remote renewable energy sources to the grid.

2. Smart Grids:

Smart grids use digital technology to monitor and manage electricity flow, improving efficiency, reliability, and integration of renewables.

3. Energy Storage:

Advances in battery storage and other energy storage technologies help balance supply and demand, reducing the need for costly grid upgrades.

4. Superconductors:

Superconducting materials, which have zero electrical resistance, are being explored for use in transmission lines to eliminate energy losses.

5. Distributed Generation:

Small-scale power generation (e.g., rooftop solar panels) reduces reliance on long-distance transmission and can enhance grid resilience.

III. Hydraulic energy transport

Hydraulic energy is a form of renewable energy derived from the movement or pressure of water. It is one of the oldest and most widely used sources of energy, with applications ranging from ancient water wheels to modern hydropower plants. Hydraulic energy is harnessed by converting the kinetic or potential energy of water into mechanical or electrical energy.

Hydraulic energy transport is a critical component of water resource management and renewable energy systems. The choice of method depends on factors like geography, scale, cost, and intended application.

1. Open-Channel Flow

- **Description:** Water is transported through open channels, such as rivers, canals, or aqueducts (Figure 10).



Figure 10. Open-Channel Flow

- **Applications:**
 - Irrigation systems for agriculture.
 - Water supply for communities.
 - Transporting water to hydropower plants.
- **Advantages:**
 - Low cost for large-scale water transport.
 - Minimal energy input required (relies on gravity).
- **Challenges:**
 - Water loss due to evaporation or seepage.
 - Limited control over flow rate.

2. Pressurized Pipelines

- **Description:** Water is transported through closed pipelines under pressure (Figure 11), often using pumps to maintain flow.



Figure 11. Pressurized Pipelines

- **Applications:**
 - Urban water supply systems.
 - Industrial processes requiring high-pressure water.
 - Pumped-storage hydropower systems.
- **Advantages:**
 - Efficient and controlled water transport.
 - Reduced water loss compared to open channels.
- **Challenges:**
 - High initial cost for pipeline construction.
 - Energy required for pumping.

3. Pumped-Storage Systems

- **Description:** Water is pumped from a lower reservoir to a higher reservoir (Figure 12) during periods of low energy demand. When energy is needed, the water is released back to the lower reservoir through turbines to generate electricity.

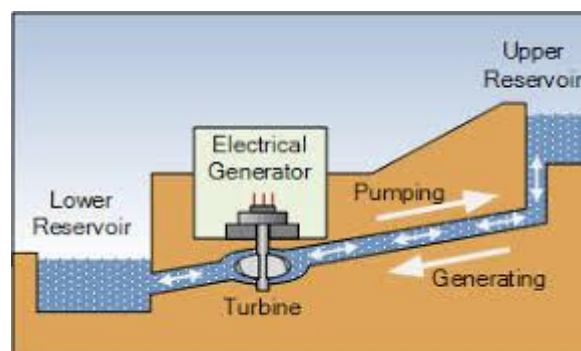

Figure 12. Pumped-Storage System

- **Applications:**
 - Energy storage and grid stabilization.
 - Balancing supply and demand in electricity networks.

- **Advantages:**
 - Provides large-scale energy storage.
 - Highly efficient and reliable.
- **Challenges:**
 - Requires specific geographical features (e.g., two reservoirs at different elevations).
 - High construction and maintenance costs.

4. Penstocks

- **Description:** Penstocks (Figure 13)are large pipes or conduits that transport water from a reservoir or intake to a turbine in a hydropower plant.



Figure 13. Penstocks

- **Applications:**
 - Hydropower generation.
- **Advantages:**
 - Efficient transport of water under high pressure.
 - Directly converts water energy into mechanical energy.
- **Challenges:**
 - Requires precise engineering to handle high pressure.
 - Maintenance can be challenging.

5. Tunnels and Aqueducts

- **Description:** Tunnels and aqueducts (Figure 14) are used to transport water over long distances or through obstacles like mountains.



Figure 14. Tunnels and Aqueducts

- **Applications:**
 - Water supply for cities and agriculture.
 - Hydropower projects in mountainous regions.
- **Advantages:**
 - Can transport large volumes of water over long distances.
 - Minimal environmental impact compared to open channels.
- **Challenges:**
 - High construction costs.
 - Requires advanced engineering and planning.

6. Hydraulic Accumulators

- **Description:** Hydraulic accumulators (Figure 15) store pressurized water or fluid, which can be released to transport energy when needed.



Figure 15. Hydraulic accumulators

- **Applications:**
 - Industrial machinery and equipment.
 - Energy recovery systems.

- **Advantages:**
 - Provides instant energy when required.
 - Efficient for small-scale energy transport.
- **Challenges:**
 - Limited storage capacity.
 - Requires regular maintenance.

7. Gravity-Based Systems

- **Description:** Water is transported using gravity (figure 16), without the need for pumps or external energy input.

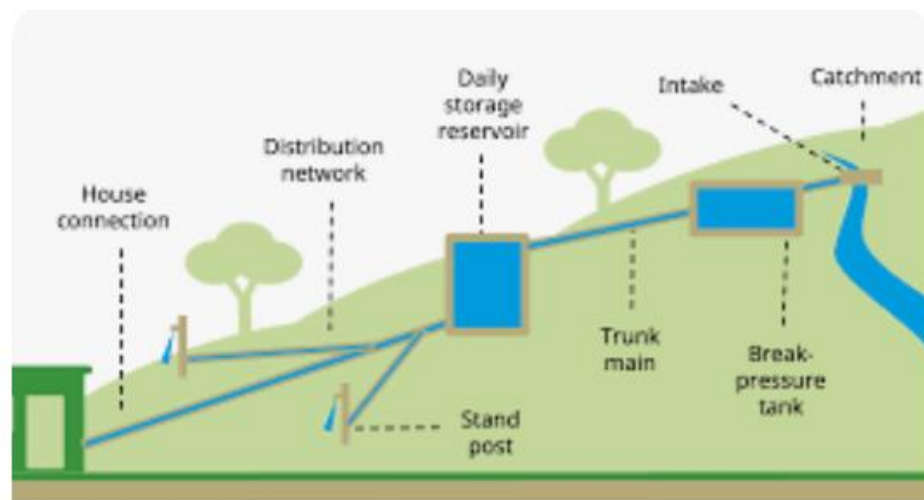

Figure 16. Gravity-Based System

- **Applications:**
 - Natural river systems.
 - Gravity-fed irrigation systems.
- **Advantages:**
 - No energy costs for transport.
 - Simple and reliable.
- **Challenges:**
 - Limited to areas with suitable elevation differences.
 - Less control over flow rate.

8. Tidal and Wave Energy Transport

- **Description:** Ocean tides and waves (Figure 17) are harnessed to transport hydraulic energy, which is then converted into electricity.



Figure 17. Tidal and Wave Energy Transport

- **Applications:**
 - Tidal power plants.
 - Wave energy converters.
- **Advantages:**
 - Renewable and predictable energy source.
 - High energy density.
- **Challenges:**
 - High installation and maintenance costs.
 - Limited to coastal regions.

Comparison of Methods (Table 2)

Table 2. Comparison of Methods of Hydraulic energy transport

Method	Energy Efficiency	Cost	Applications
Open-Channel Flow	Moderate	Low	Irrigation, water supply
Pressurized Pipelines	High	High	Urban water supply, industrial use
Pumped-Storage Systems	Very High	Very High	Energy storage, grid stabilization
Penstocks	High	High	Hydropower generation
Tunnels and Aqueducts	Moderate	Very High	Long-distance water transport
Hydraulic Accumulators	High	Moderate	Industrial machinery, energy recovery
Gravity-Based Systems	High	Low	Natural water flow, irrigation
Tidal and Wave Energy	Moderate	Very High	Coastal energy generation

IV. Thermal energy transport

Thermal energy transport refers to the movement of heat from one location to another. This process is essential in various applications, including power generation, heating and cooling systems, industrial processes, and electronics cooling. There are three primary methods of thermal energy transport: conduction, convection, and radiation. Additionally, advanced methods like heat pipes and thermoelectric systems are used in specific applications.

Thermal energy transport is a fundamental aspect of energy systems, and the choice of method depends on factors like the application, scale, and efficiency requirements. Let me know if you'd like to explore any specific method or application further!

Below is an overview of these methods:

1. Conduction

- **Description:** Heat transfer through a solid material or stationary fluid due to temperature differences within the material (Figure 18).

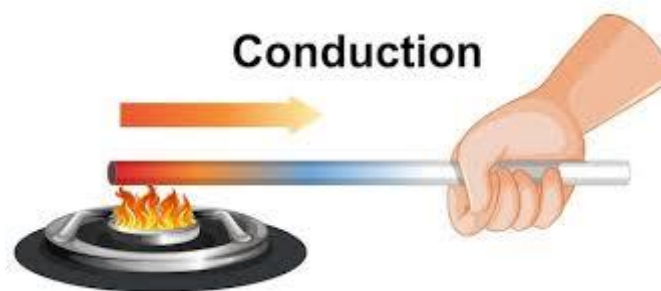

Figure 18. Conduction transport

- **Mechanism:** Heat is transferred by the vibration and collision of molecules or electrons.
- **Applications:**
 - Heat sinks in electronics.
 - Insulation materials in buildings.
 - Cooking utensils (e.g., metal pots).
- **Advantages:**
 - Simple and reliable.
 - No moving parts required.
- **Challenges:**
 - Limited to solid materials or stationary fluids.
 - Efficiency depends on the material's thermal conductivity.

2. Convection

- **Description:** Heat transfer through the movement of fluids (liquids or gases) caused by temperature differences (Figure 19).

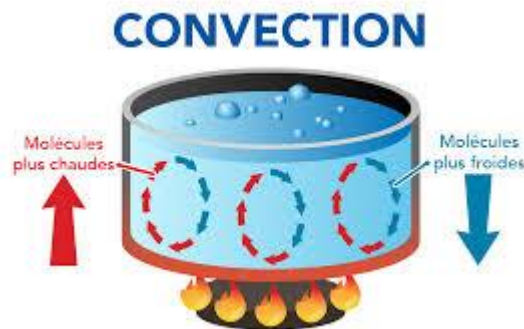

Figure 19. Convection transport

- **Types:**
 - **Natural Convection:** Fluid movement occurs due to density differences caused by temperature gradients (e.g., warm air rising).
 - **Forced Convection:** Fluid movement is driven by external means like fans or pumps (e.g., HVAC systems).
- **Applications:**
 - Heating and cooling systems (e.g., radiators, air conditioners).
 - Industrial heat exchangers.
 - Oceanic and atmospheric heat transport.
- **Advantages:**
 - Efficient for large-scale heat transfer.
 - Can be controlled using pumps or fans.
- **Challenges:**
 - Requires energy input for forced convection.
 - Limited by fluid properties (e.g., viscosity, thermal conductivity).

3. Radiation

- **Description:** Heat transfer through electromagnetic waves (infrared radiation) without the need for a medium (Figure 20).

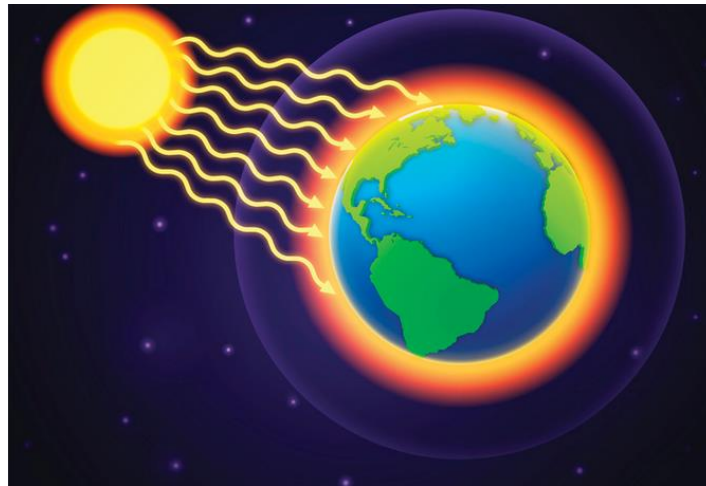

Figure 20. Radiation transport

- **Mechanism:** All objects emit thermal radiation depending on their temperature.
- **Applications:**
 - Solar energy collection.
 - Space heating (e.g., radiant heaters).
 - Thermal imaging and remote sensing.
- **Advantages:**
 - Can occur in a vacuum (e.g., heat from the Sun reaching Earth).
 - No contact or medium required.
- **Challenges:**
 - Efficiency depends on surface properties (e.g., emissivity).
 - Limited by the inverse square law (intensity decreases with distance).

4. Heat Pipes

- **Description:** A highly efficient method of heat transport using the phase change of a working fluid (evaporation and condensation). Figure 21

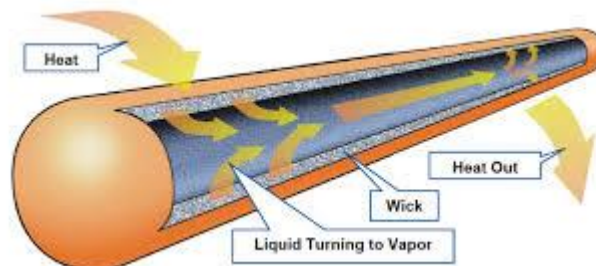

Figure 21. Heat Pipes

- **Mechanism:** Heat is absorbed at one end (evaporator), causing the fluid to evaporate. The vapor travels to the other end (condenser), where it releases heat and condenses back into liquid.
- **Applications:**
 - Cooling of electronics (CPUs: Central Processing Units and GPUs : Graphics Processing Units),
 - Aerospace thermal management.
 - Renewable energy systems (e.g., solar thermal collectors).
- **Advantages:**
 - High thermal conductivity.
 - Passive operation (no moving parts).
- **Challenges:**
 - Limited by the working fluid's properties.
 - Requires precise design and manufacturing.

5. Thermoelectric Systems

- **Description:** Heat transport using the Peltier effect (Figure 20), where an electric current creates a temperature difference across a thermoelectric material.

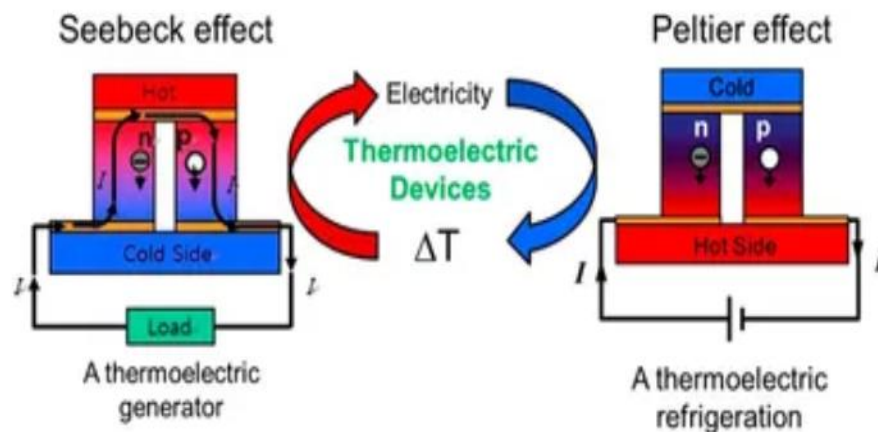

Figure 20. Heat transport using the Peltier effect

- **Mechanism:** Electrical energy is used to move heat from one side of the material to the other.
- **Applications:**
 - Portable cooling devices (e.g., mini-fridges).
 - Waste heat recovery in industrial processes.
 - Precision temperature control in scientific instruments.

- **Advantages:**
 - Compact and lightweight.
 - No moving parts or working fluids.
- **Challenges:**
 - Low efficiency compared to other methods.
 - High cost of thermoelectric materials.

6. Phase Change Materials (PCMs)

- **Description:** Heat transport using materials (Figure 21) that absorb or release heat during phase transitions (example: solid to liquid).

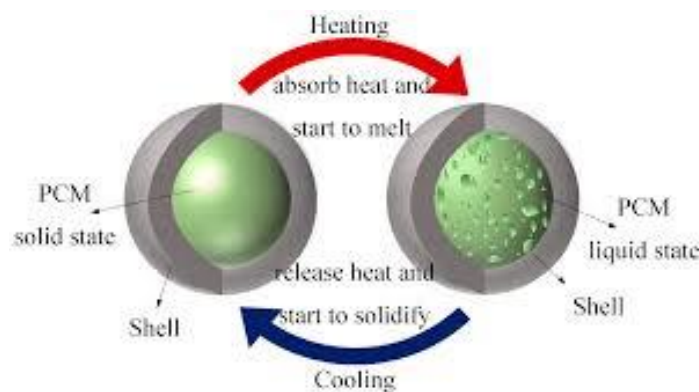

Figure 21. Heat transport using materials

- **Mechanism:** PCMs store thermal energy when melting and release it when solidifying.
- **Applications:**
 - Thermal energy storage in buildings.
 - Temperature regulation in textiles and packaging.
 - Solar energy storage systems.
- **Advantages:**
 - High energy storage density.
 - Passive operation.
- **Challenges:**
 - Limited by the phase change temperature range.
 - Requires containment to prevent leakage.

Comparison of Methods (Table 3)

Table 3. Comparison of Thermal energy transport

Method	Mechanism	Efficiency	Applications
Conduction	Molecular vibration and collision	Moderate	Electronics, insulation, cooking
Convection	Fluid movement (natural or forced)	High	HVAC, heat exchangers, oceanic heat
Radiation	Electromagnetic waves	Low to Moderate	Solar energy, space heating, imaging
Heat Pipes	Phase change of working fluid	Very High	Electronics cooling, aerospace
Thermoelectric Systems	Peltier effect	Low	Portable cooling, waste heat recovery
Phase Change Materials	Heat absorption/release during phase change	Moderate	Thermal storage, textiles, solar energy

Chapter 4: Energy Storage

Why store energy?

Energy storage is used to meet three main needs:

- The need to move around with your own energy source, which is the need for autonomy.
- The need to compensate for the time lag between energy demand and production capacity.
- The need to compensate for fluctuations in the intensity of the current delivered on the electric grid, for example in the case of wind turbines.

I. Interest

Energy storage has garnered significant interest due to its critical role in addressing various challenges in the energy sector, enabling a more sustainable, reliable, and efficient energy system. Here are some key reasons for the growing interest in energy storage:

1. Integration of renewable energy

- Renewable energy sources like solar and wind are intermittent, meaning they don't generate power consistently. Energy storage systems (ESS) can store excess energy when production is high and release it when production is low, ensuring a stable energy supply.
- This helps reduce reliance on fossil fuels and supports the transition to a low-carbon energy system.

2. Grid stability and reliability

- Energy storage can provide grid operators with tools to balance supply and demand in real-time, reducing the risk of blackouts and improving grid resilience.
- It can also provide ancillary services like frequency regulation, voltage support, and spinning reserves.

3. Peak Shaving and Load Management

- Energy storage can reduce peak demand on the grid by storing energy during off-peak hours and discharging it during peak hours. This helps utilities avoid the need for expensive peaking power plants and reduces overall energy costs.

4. Decentralization and Energy Independence

- Energy storage enables decentralized energy systems, such as microgrids and home energy systems, allowing consumers to generate, store, and use their own energy.
- This reduces dependence on centralized power grids and enhances energy security.

5. Electrification of Transportation

- The rise of electric vehicles (EVs) has increased the demand for energy storage solutions, both in vehicles and in charging infrastructure.

- Battery storage systems are essential for managing the charging load and supporting the widespread adoption of EVs.

6. Cost Reductions and Technological Advancements

- The cost of energy storage technologies, particularly lithium-ion batteries, has decreased significantly over the past decade, making them more accessible and economically viable.
- Ongoing research and development are improving the efficiency, lifespan, and sustainability of energy storage systems.

7. Climate Change Mitigation

- Energy storage plays a vital role in reducing greenhouse gas emissions by enabling greater use of renewable energy and improving energy efficiency.
- It supports global efforts to meet climate goals, such as those outlined in the Paris Agreement.

8. Energy Access in Remote Areas

- In remote or off-grid areas, energy storage combined with renewable energy systems can provide reliable and affordable electricity, improving quality of life and supporting economic development.

9. Resilience Against Natural Disasters

- Energy storage systems can provide backup power during natural disasters or grid outages, ensuring critical infrastructure (e.g., hospitals, emergency services) remains operational.

10. Economic Opportunities

- The energy storage industry is creating new jobs and business opportunities in manufacturing, installation, maintenance, and research and development.
- It is also driving innovation in related sectors, such as smart grids and energy management systems.

II. Energy storage efficiency

Energy storage efficiency refers to the ratio of energy output to energy input in an energy storage system. It is a critical metric for evaluating the performance and economic viability of storage technologies. High efficiency means less energy is lost during the storage and retrieval process, making the system more cost-effective and environmentally friendly.

Round-trip efficiency is the most commonly used measure of energy storage efficiency. It represents the percentage of energy that can be retrieved from the storage system relative to the amount of energy initially stored.

$$\text{Efficiency} = \left(\frac{\text{Energy output}}{\text{Energy input}} \right) \times 100 \quad (6)$$

Factors Affecting Efficiency

- Conversion losses: Heat dissipation, friction, and chemical inefficiencies.
- Self-discharge: Some systems lose stored energy over time.
- Depth of discharge (DoD): Some batteries lose efficiency if deeply discharged frequently.
- Temperature effects: Extreme temperatures can reduce efficiency.

III. Forms of energy storage

1. Mechanical storage:

Mechanical energy storage systems store energy in the form of potential energy (elevated mass or compressed air) or kinetic energy (rotating flywheels). These systems are widely used for large-scale energy storage, grid stabilization, and balancing supply and demand in power systems. Below is a detailed overview of mechanical energy storage technologies, including pumped hydro storage, compressed air energy storage (CAES), and flywheel energy storage.

A. Pumped Hydro Storage (PHS)

Operating principle:

- Stores energy by pumping water (Figure 1.) from a lower reservoir to a higher reservoir during periods of low energy demand (charging).
- During periods of high demand, the water is released back to the lower reservoir through turbines to generate electricity (discharging).

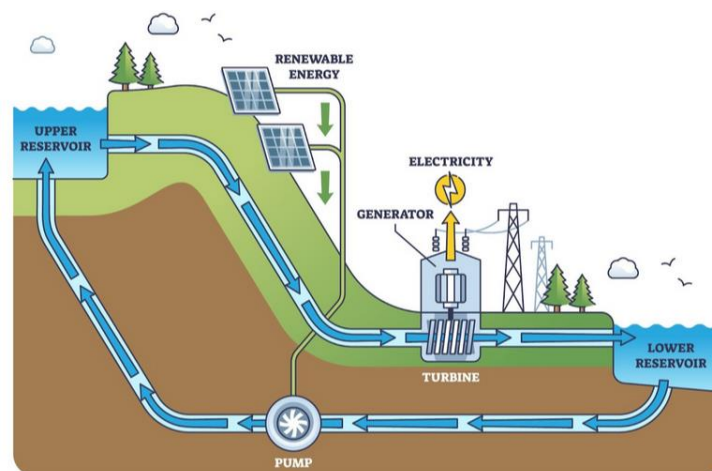

Figure 1. Pumped Hydro Storage

Key Features:

- **Energy Storage Mechanism:** Gravitational potential energy.
- **Capacity:** Large-scale (hundreds of MW to GW).
- **Efficiency:** 70–85%.
- **Lifespan:** 50+ years.
- **Response Time:** Minutes to hours.

Advantages:

- **High Energy Capacity:** Suitable for long-duration storage.
- **Proven Technology:** Widely deployed and reliable.
- **Low Operating Costs:** Once built, operational costs are minimal.

Challenges:

- **Geographical Limitations:** Requires specific terrain with elevation differences.
- **High Capital Costs:** Expensive to construct.
- **Environmental Impact:** Can affect local ecosystems and water resources.

Applications:

- Grid-scale energy storage.
- Balancing renewable energy generation (example: solar and wind).
- Peak shaving and load leveling.

B. Compressed Air Energy Storage (CAES)

Compressed air can be used to produce mechanical work. When there is high demand for electricity, previously compressed and stored air is used to drive a turbine (Figure 2) which, thanks to an alternator, produces electricity. One of the advantages of the solution is that it generates only a few risks (no or few toxic products, rare metals, etc.) and has no geographical constraints (decentralized solution) or scale provided an electricity source is available.

Operating principle:

- Stores energy by compressing air and storing it in underground caverns or tanks during periods of low energy demand.
- During high demand, the compressed air is released, heated, and expanded through turbines to generate electricity.

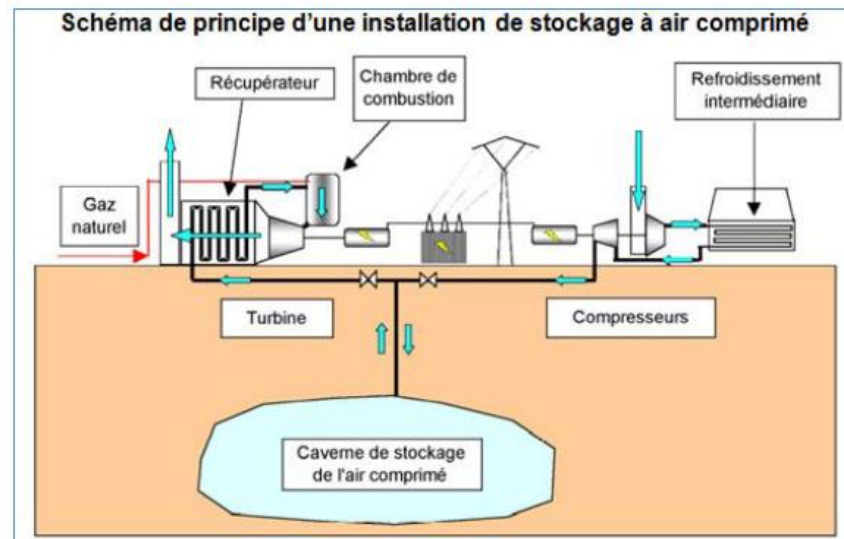

Figure 2. Compressed Air Energy Storage (CAES)

Key Features:

- **Energy Storage Mechanism:** Potential energy (compressed air).
- **Capacity:** Medium to large-scale (tens to hundreds of MW).
- **Efficiency:** 40–70% (depending on the system design).
- **Lifespan:** 20–40 years.
- **Response Time:** Minutes to hours.

Types of CAES:

1. Diabatic CAES:

- Uses natural gas or other fuels to reheat the compressed air before expansion.
- Lower efficiency (40–50%).

2. Adiabatic CAES:

- Stores the heat generated during compression and reuses it during expansion.
- Higher efficiency (up to 70%).

Advantages:

- **Scalable:** Suitable for large-scale energy storage.
- **Long Duration:** Can store energy for hours to days.
- **Uses Existing Infrastructure:** Can utilize depleted gas fields or salt caverns.

Challenges:

- **Geographical Limitations:** Requires suitable underground storage sites.
- **Lower Efficiency:** Compared to other storage technologies.
- **High Capital Costs:** Expensive to construct and maintain.

Applications:

- Grid-scale energy storage.
- Renewable energy integration.
- Backup power for utilities.

C. Kinetic energy storage (Flywheel Energy Storage: FES)

Flywheels store energy in kinetic form. They consist of a rotating mass around an axis. Flywheels are devices that charge and discharge in a few seconds to a minute. They are therefore reserved for applications where the storage cycles are short.

Operating principle:

- Stores energy in the form of rotational kinetic energy by spinning a rotor (flywheel) at very high speeds.
- Energy is stored by accelerating the flywheel and retrieved by decelerating it.

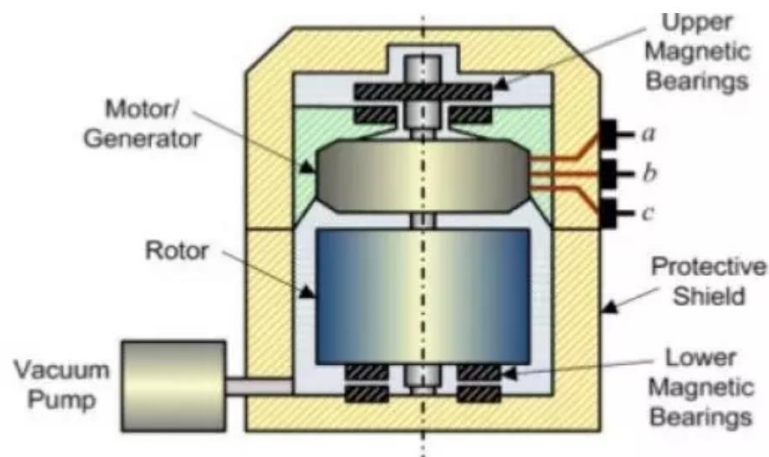

Figure 3. Flywheel Energy Storage

Key Features:

- **Energy Storage Mechanism:** Kinetic energy.
- **Capacity:** Small to medium-scale (kW to MW).
- **Efficiency:** 85–95%.
- **Lifespan:** 20+ years.
- **Response Time:** Milliseconds to seconds.

Key Components:

- **Rotor:** High-speed rotating mass (often made of carbon fiber or steel).
- **Bearings:** Magnetic or mechanical bearings to reduce friction.
- **Vacuum Enclosure:** Minimizes air resistance and energy loss.

Advantages:

- **High Power Density:** Delivers energy quickly.
- **Long Cycle Life:** Can undergo millions of charge/discharge cycles.
- **Low Maintenance:** Few moving parts and no chemical reactions.
- **Fast Response:** Ideal for grid stabilization and frequency regulation.

Challenges:

- **Low Energy Density:** Stores less energy compared to batteries or pumped hydro.
- **Self-Discharge:** Energy loss due to friction and air resistance (minimized in advanced systems).
- **High Cost:** Expensive for large-scale applications.

Applications:

- Grid stabilization and frequency regulation.
- Uninterruptible power supplies (UPS).
- Regenerative braking in transportation.
- Renewable energy integration.

2. Electrochemical and Electrostatic storage storage

A. Electrochemical storage of electrical energy

Electrochemical storage of electrical energy involves converting electrical energy into chemical energy during charging and reversing the process during discharging. This method is widely used in batteries and supercapacitors, which are essential for portable electronics, electric vehicles (EVs), and grid-scale energy storage.

Electricity cannot be stored directly. It is therefore essential to convert the energy into other forms in order to store it. The use of batteries makes it possible to store electrical energy in electrochemical form.

The 3 main parameters that characterize batteries are:

- **Voltage or potential difference at the terminals of the battery.** It is expressed in volts (V).
- **The capacity of the battery** represents the amount of electric charge it can store. It is expressed in Coulombs (C) or Ampere-hours (Ah). $1\text{Ah} = 3600\text{C}$.

The capacity is often related to the mass (mass capacity) or volume (volume capacity).

- **The energy density of the battery** is the amount of energy stored per unit of mass or volume. It is expressed in Wh/kg or Wh/L.

Types of Electrochemical Storage Systems

a) Lithium-Ion Batteries (Li-ion)

- **Efficiency:** 85-95%
- **Advantages:**
 - High energy density.
 - Long cycle life (~1000-10,000 cycles).
 - Fast charging and discharging.
- **Challenges:**
 - Thermal runaway risks (overheating).
 - Expensive raw materials (lithium, cobalt).
- **Applications:** Electric vehicles (EVs), grid storage, consumer electronics.

b) Lead-Acid Batteries

- **Efficiency:** 70-85%
- **Advantages:**
 - Low cost and mature technology.
 - Recyclable (~99% of lead is reusable).
- **Challenges:**
 - Low energy density.
 - Short cycle life (~500-1000 cycles).
- **Applications:** Backup power (UPS), solar storage, automotive starting batteries.

c) Sodium-Ion Batteries (Na-ion)

- **Efficiency:** 85-90%
- **Advantages:**
 - Uses abundant sodium instead of lithium.
 - Similar performance to Li-ion but cheaper.
- **Challenges:**
 - Lower energy density compared to Li-ion.
- **Applications:** Grid-scale energy storage, low-cost battery systems.

d) Flow Batteries (Vanadium Redox, Zinc-Bromine)

- **Efficiency:** 60-85%
- **Advantages:**
 - Long lifespan (~10,000+ cycles).
 - Scalable for large energy storage.

- **Challenges:**
 - Lower efficiency compared to Li-ion.
 - Heavy and requires large storage tanks.
- **Applications:** Grid storage, renewable energy integration.

e) Solid-State Batteries

- **Efficiency:** 90-98% (theoretical)
- **Advantages:**
 - Higher safety (no liquid electrolyte).
 - Higher energy density than Li-ion.
- **Challenges:**
 - Expensive and still under development.
- **Applications:** Future EVs, aerospace, advanced grid storage.

Table 1. Comparison of different technologies used in battery

Battery Type	Density (Wh/kg)	Power Range	Efficiency	Uses
Lead-Acid	50	100W to 10MW	70 to 85%	Road vehicles, electric vehicles, off-grid sites.
NiCd Nickel-Cadmium	50	Few Watts	70 to 80%	Portable tools, electric shavers
NiMH Nickel Metal Hydride	75	Few Watts	70 to 80%	Mobile phones, cameras, electric shavers
Li-ion Lithium-ion	300	100W to 10MW	85 to 90%	Mobile phones, electric vehicles, cameras, laptops
Li-Po Lithium-Polymer	120	100W to 10MW	85 to 90%	Light electric vehicles, mobile phones
Na-S Sodium-Sulfur	100 to 120	50kW to 10MW	85 to 90%	Energy storage integrated into an electricity production system

Capacity of a battery association

The capacity represents the amount of electric charge stored in the battery, but not the amount of energy. To know this amount of energy (which is expressed in Watt-hours (Wh)), you have to multiply the capacity by the battery voltage:

$$Wh = Ah \times V \quad (7)$$

It is important not to confuse current quantity and energy quantity. For example, if two 12V 100Ah batteries are connected in series (Figure 4), the equivalent is a 24V 100Ah battery, while the amount of energy has doubled.

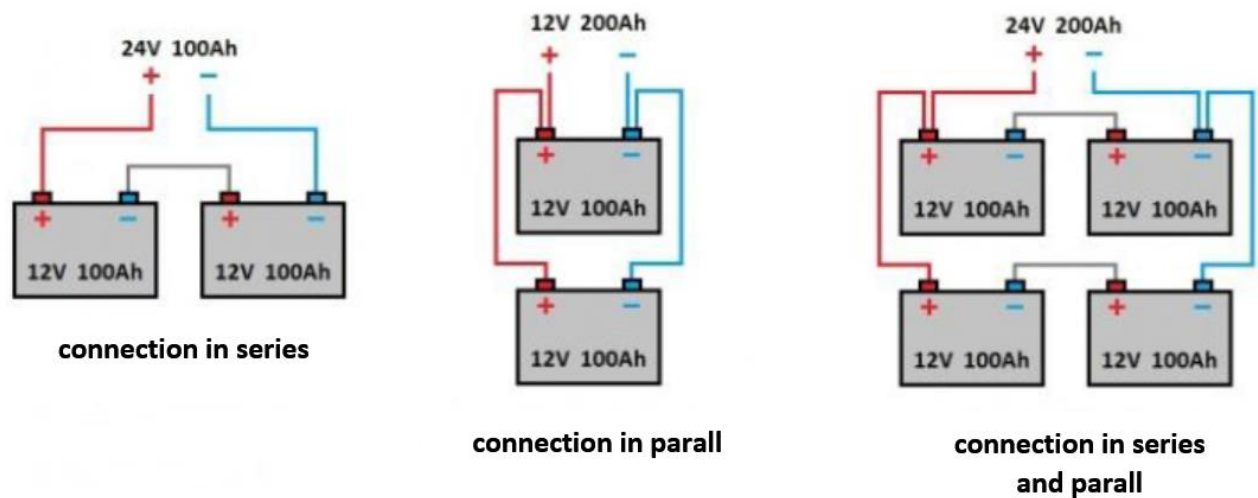

Figure 4. battery associations

Applications of Electrochemical Storage

1. **Portable Electronics:** Smartphones, laptops, tablets.
2. **Electric Vehicles (EVs):** Batteries provide the primary energy source for EVs.
3. **Grid Storage:** Stabilizing renewable energy integration and providing backup power.
4. **Uninterruptible Power Supplies (UPS):** Backup power for critical infrastructure.
5. **Aerospace:** Powering satellites and spacecraft.

Future Trends in Electrochemical Storage

1. **Solid-State Batteries:** Promising higher energy density, safety, and efficiency.
2. **Beyond Lithium-Ion:** Development of sodium-ion, magnesium-ion, and other alternative chemistries.
3. **Recycling and Sustainability:** Improved recycling methods to recover valuable materials and reduce environmental impact.
4. **AI and Smart Management:** Advanced algorithms to optimize battery performance and lifespan.
5. **Hybrid Systems:** Combining batteries with supercapacitors for high energy and power density.

B. Electrostatic storage of electrical energy

Electrostatic energy storage refers to systems that store energy in an electric field, primarily using capacitors and supercapacitors. These devices do not rely on chemical reactions, making them extremely efficient and fast at charging and discharging.

Types of Electrostatic Energy Storage

a) Capacitors

- **Operating principle:**

Store energy in an electric field between two conductive plates separated by a dielectric (insulating) material (Figure 5).

- **Efficiency:** 95-99% (very low energy loss).

- **Advantages:**

- Extremely fast charge and discharge times.
- Very long lifespan (millions of cycles).
- No chemical degradation.

- **Challenges:**

- Low energy storage capacity.
- Not suitable for long-term energy storage.

- **Applications:**

Electronic circuits, power conditioning, filtering, and high-speed applications.

b) Supercapacitors (Ultracapacitors)

- **How They Work:**

Similar to capacitors but use a double-layer charge storage mechanism (electric double-layer capacitance and pseudocapacitance).

- **Efficiency:** 85-98%.

- **Advantages:**

- High power density (can deliver bursts of energy quickly).
- Long cycle life (~1,000,000+ cycles).
- Rapid charging (seconds to minutes).

- **Challenges:**

- Lower energy density compared to batteries.
- Higher self-discharge rate.

- **Applications:**

- Regenerative braking in electric vehicles, power backup, and grid stability.

The use of capacitors or supercapacitors makes it possible to store electrical energy in electrostatic form. The electrical capacitance of a capacitor or supercapacitor is essentially determined by the geometry of the armatures and the nature of the insulant(s). The following simplified formula is often used:

$$C = (\epsilon.S)/e \quad (8)$$

with: C: capacitance in farads (F)

S: area of the armatures (m²)

ϵ : permittivity of the dielectric (F/m)

e: distance between the armatures (m)

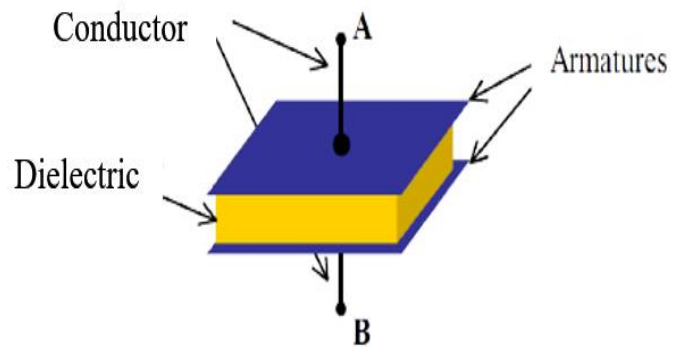

Figure 5. Capacitor

Applications of Electrostatic Storage

1. Short-Term Energy Storage:

Used in applications requiring quick energy bursts, such as camera flashes or defibrillators.

2. Regenerative Braking:

In electric vehicles (EVs) and hybrid vehicles, supercapacitors capture and store energy during braking, which can then be used for acceleration.

3. Grid Stabilization:

Provide rapid response to fluctuations in power demand or supply, helping to stabilize the grid.

4. Backup Power:

Used in uninterruptible power supplies (UPS) to provide short-term power during outages.

5. Consumer Electronics:

Used in devices requiring quick energy delivery, such as smartphones and laptops.

6. Renewable Energy Integration:

Smooth out intermittent power generation from solar and wind sources.

Advantages of Electrostatic Storage

1. Fast Charge/Discharge:

Can deliver or absorb energy in milliseconds to seconds.

2. High Cycle Life:

Minimal degradation over hundreds of thousands of cycles.

3. Low Maintenance:

No moving parts and no chemical reactions, reducing wear and tear.

4. Wide Temperature Range:

Operates effectively in extreme temperatures.

5. Environmentally Friendly:

Does not rely on toxic or rare materials, making it easier to recycle.

Challenges and Limitations

1. Low Energy Density:

Stores significantly less energy than batteries, limiting its use for long-term storage.

2. Self-Discharge:

Electrostatic systems can lose charge over time, especially at higher temperatures.

3. High Cost:

Supercapacitors are more expensive per unit of energy stored compared to batteries.

4. Voltage Limitations:

The energy stored is proportional to the square of the voltage, requiring careful voltage management.

Future Trends in Electrostatic Storage

1. Hybrid Systems:

Combining supercapacitors with batteries to leverage the high power density of supercapacitors and the high energy density of batteries.

2. Advanced Materials:

Development of new electrode materials (example: graphene, carbon nanotubes) to increase energy density.

3. Solid-State Supercapacitors:

Using solid electrolytes to improve safety and performance.

4. Integration with Renewable Energy:

Enhancing the ability to store and deliver energy from intermittent sources like solar and wind.

5. Cost Reduction:

Scaling up production and improving manufacturing processes to reduce costs.

3. Chemical storage: hydrogen and methane

Chemical energy storage involves storing energy in the form of chemical bonds, which can be released through chemical reactions such as combustion or electrochemical processes. Two prominent examples of chemical energy storage are hydrogen and methane. These fuels are versatile and can be used for a wide range of applications, including transportation, grid storage, and industrial processes. Below is a detailed overview of hydrogen and methane as chemical energy storage mediums.

A. Hydrogen Energy Storage

Operating principle:

- **Production:** Hydrogen is produced through processes like electrolysis (splitting water into hydrogen and oxygen using electricity) or steam methane reforming (SMR, reacting methane with steam to produce hydrogen and carbon dioxide) (Figure 6).
- **Storage:** Hydrogen can be stored as a gas (compressed), liquid (cryogenically cooled), or in chemical compounds (e.g., ammonia, metal hydrides).
- **Usage:** Hydrogen can be used in fuel cells to generate electricity or combusted directly for heat and power.

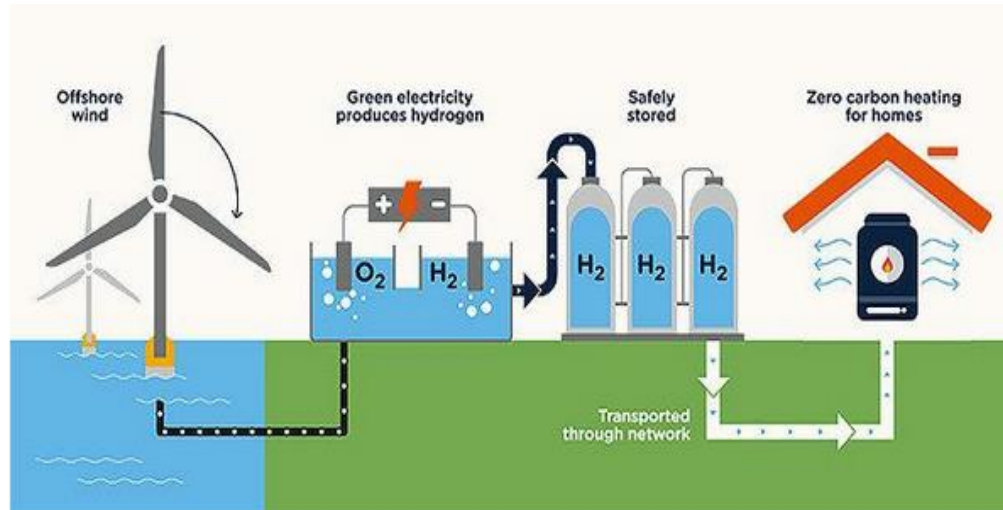

Figure 6. Hydrogen Energy Storage

Key Features:

- **Energy Density:**
 - Gravimetric: High (120–142 MJ/kg).
 - Volumetric: Low (requires compression or liquefaction for practical storage).
- **Efficiency:**

- Electrolysis: 60–80%.
- Fuel Cells: 40–60%.
- **Lifespan:** Long (decades for storage systems).
- **Response Time:** Seconds to minutes.

Advantages:

- **Clean Energy Carrier:** Produces only water when used in fuel cells.
- **Versatility:** Can be used for electricity generation, transportation, and industrial processes.
- **Renewable Integration:** Can store excess renewable energy (from solar or wind) through electrolysis.
- **High Energy Density:** Lightweight and energy-dense by mass.

Challenges:

- **Storage and Transport:** Requires high-pressure tanks, cryogenic temperatures, or chemical carriers, which are expensive and energy-intensive.
- **Production Costs:** Electrolysis is currently expensive, and SMR produces CO₂ emissions.
- **Infrastructure:** Limited hydrogen refueling and distribution infrastructure.
- **Safety:** Hydrogen is highly flammable and requires careful handling.

Applications:

- **Transportation:** Fuel cell vehicles (FCVs), buses, and trucks.
- **Grid Storage:** Long-duration energy storage for renewable energy integration.
- **Industrial Processes:** Refining, ammonia production, and steel manufacturing.
- **Power Generation:** Backup power and distributed energy systems.

B. Methane Energy Storage**Operating principle:**

- **Production:** Methane can be produced through **power-to-gas** (P2G) technology, where excess electricity is used to produce hydrogen via electrolysis (figure 7), which is then converted to methane via **methanation** (reacting hydrogen with CO₂).

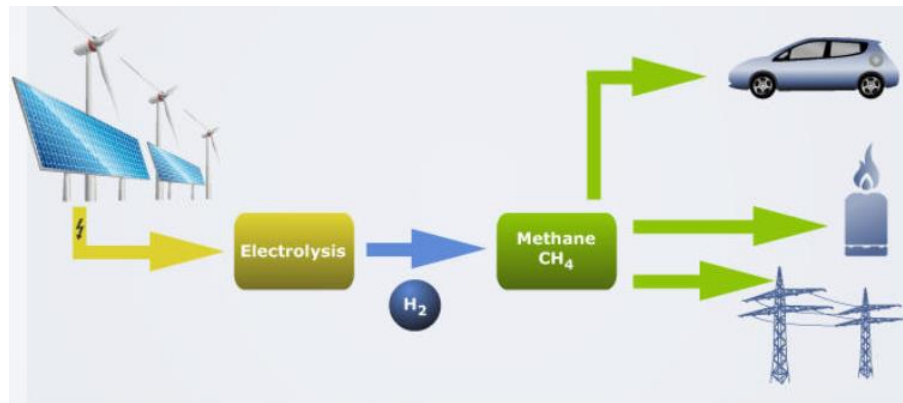

Figure 7. Methane Energy Storage

- **Storage:** Methane can be stored in natural gas pipelines, underground storage facilities, or liquefied natural gas (LNG) tanks.
- **Usage:** Methane can be combusted in power plants, used as a fuel for vehicles, or injected into the natural gas grid.

Key Features:

- **Energy Density:**
 - Gravimetric: 50–55 MJ/kg.
 - Volumetric: Higher than hydrogen (easier to store and transport).
- **Efficiency:**
 - Electrolysis + Methanation: 50–70%.
 - Combustion: 35–60% (depending on the application).
- **Lifespan:** Long (decades for storage systems).
- **Response Time:** Minutes to hours.

Advantages:

- **Existing Infrastructure:** Can leverage existing natural gas pipelines and storage facilities.
- **High Energy Density:** Easier to store and transport than hydrogen.
- **Renewable Integration:** Can store excess renewable energy through power-to-gas.
- **Versatility:** Can be used for electricity generation, heating, and transportation.

Challenges:

- **CO₂ Emissions:** Combustion of methane produces CO₂, though it can be offset by using renewable methane.
- **Production Costs:** Power-to-gas is currently expensive and energy-intensive.
- **Methanation Efficiency:** Losses occur during the conversion of hydrogen to methane.

- **Methane Leakage:** Methane is a potent greenhouse gas, and leaks can offset its climate benefits.

Applications:

- **Grid Storage:** Long-duration energy storage for renewable energy integration.
- **Transportation:** Compressed natural gas (CNG) vehicles.
- **Power Generation:** Backup power and peaking plants.
- **Industrial Processes:** Heating and feedstock for chemical production.

4. Thermal and thermochemical storage: sensible heat, latent heat, energy by sorption

Thermal and thermochemical energy storage systems store energy in the form of heat or chemical reactions. These systems are particularly useful for applications such as heating, cooling, and industrial processes, as well as for integrating renewable energy sources like solar power. Below is a detailed overview of the three main types of thermal and thermochemical storage: sensible heat storage, latent heat storage, and sorption-based energy storage.

A. Sensible Heat Storage

How It Works (Figure 8):

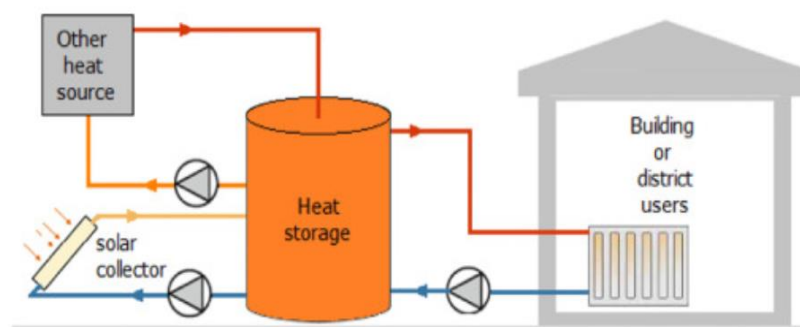

Figure 8. Heat Storage

- Stores energy by heating or cooling a material (solid or liquid) without changing its phase.
- The amount of energy stored depends on the material's specific heat capacity, mass, and temperature change:

$$Q = m \cdot c_p \cdot \Delta T \quad (9)$$

where:

- Q = energy stored (in joules),
- m = mass of the material (in kg),
- c_p = specific heat capacity (in J/kg·K),
- ΔT = temperature change (in K).

Key Materials:

- **Liquids:** Water, thermal oils, molten salts.
- **Solids:** Rocks, concrete, ceramics.

Advantages:

- **Simple Technology:** Easy to implement and widely used.
- **Low Cost:** Uses inexpensive and abundant materials.
- **Long Lifespan:** Durable with minimal degradation.

Challenges:

- **Low Energy Density:** Requires large volumes of material to store significant amounts of energy.
- **Heat Loss:** Thermal insulation is needed to minimize energy loss over time.

Applications:

- Solar water heating systems.
- District heating and cooling.
- Industrial process heat storage.

B. Latent Heat Storage (Phase Change Materials - PCMs)**Operating principle:**

- Stores energy by changing the phase of a material (example, solid to liquid or liquid to gas) at a constant temperature (Figure 9).

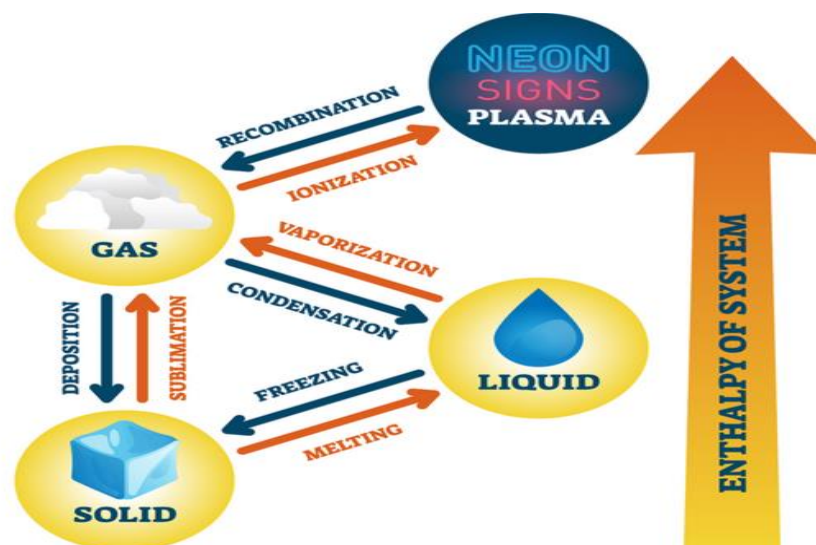

Figure 9. Stores energy by changing the phase of a material

- The energy stored is given by:

$$Q = m \cdot L \quad (10)$$

where:

- Q = energy stored (in joules),
- m = mass of the material (in kg),
- L = latent heat of fusion or vaporization (in J/kg).

Key Materials:

- **Organic PCMs:** Paraffin wax, fatty acids.
- **Inorganic PCMs:** Salt hydrates, metals, and alloys.
- **Eutectic Mixtures:** Combinations of materials with a single melting point.

Advantages:

- **High Energy Density:** Stores more energy per unit mass compared to sensible heat storage.
- **Isothermal Operation:** Releases or absorbs heat at a constant temperature.

Challenges:

- **Material Stability:** Some PCMs degrade over multiple cycles.
- **Low Thermal Conductivity:** Requires additives or enhancements to improve heat transfer.
- **Cost:** High-quality PCMs can be expensive.

Applications:

- Building heating and cooling (PCM-enhanced walls or ceilings).
- Solar thermal energy storage.
- Thermal management in electronics and batteries.

C. Sorption-Based Energy Storage

Sorption is a physical and chemical process by which one substance becomes attached to another (figure 10). Specific cases of sorption are:

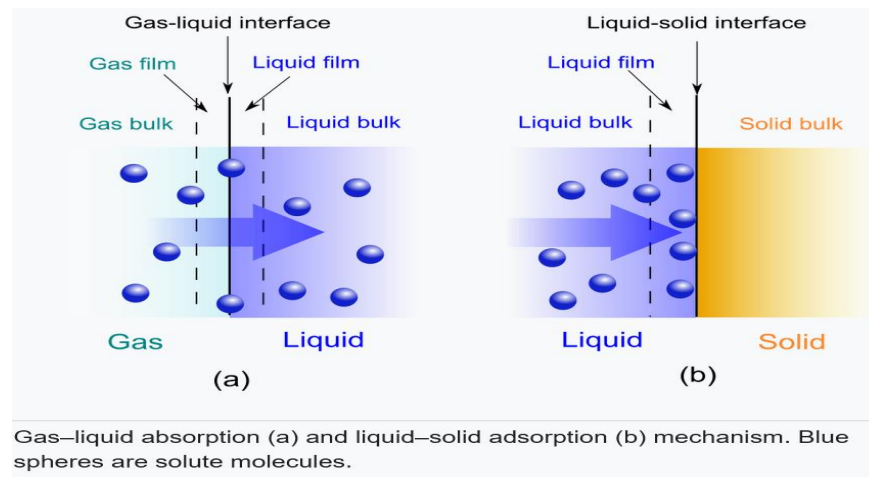

Figure 10. Sorption processes

Operating principle:

- Stores energy through **sorption processes**, which involve the attachment of a gas or liquid (sorbate) to a solid or liquid (sorbent).
- Two main types:
 - Adsorption:** the incorporation of a substance in one state into another of a different state (example: liquids being absorbed by a solid or gases being absorbed by a liquid);
 - Absorption:** The physical adherence or bonding of ions and molecules onto the surface of another phase (example: reagents adsorbed to a solid catalyst surface)
- Energy is stored by breaking the sorption bond (charging) and released by re-forming the bond (discharging).

Key Materials:

- **Adsorbents:** Silica gel, zeolites, activated carbon.
- **Absorbents:** Lithium bromide, ammonia-water solutions.

Advantages:

- **High Energy Density:** Can store large amounts of energy in chemical bonds.
- **Long-Duration Storage:** Minimal energy loss over time.
- **Versatility:** Can be used for heating, cooling, and humidity control.

Challenges:

- **Complexity:** Requires precise control of temperature and pressure.
- **Material Degradation:** Sorbents can degrade over time.
- **Cost:** High-quality sorbents and system components can be expensive.

Applications:

- Solar cooling and refrigeration.
- Seasonal thermal energy storage.
- Industrial waste heat recovery.

5. New storage technologies

The energy storage landscape is rapidly evolving, driven by the need for more efficient, sustainable, and cost-effective solutions to support renewable energy integration, grid stability, and decarbonization. Below is an overview of new and emerging energy storage technologies that are pushing the boundaries of innovation.

1. **Solid-State Batteries:** Use solid electrolytes instead of liquid. They offer higher energy density, better safety, faster charging, and longer lifespan but face high costs and scalability challenges. Used in stand for Electric Vehicles (EVs), electronics, and grid storage.
2. **Flow Batteries:** Store energy in liquid electrolytes. They provide scalability, long cycle life, and safety but have low energy density and high costs. Used for grid storage and renewable energy integration.
3. **Hydrogen and Ammonia Storage:** Chemical energy carriers for long-duration storage with high energy density and versatility. However, storage, transport, and efficiency remain challenges. Used in grid storage, industry, and transportation.
4. **Supercapacitors:** Store energy electrostatically, offering high power density, long cycle life, and fast charging. However, they have low energy density and high costs. Used for short-term storage, EV braking, and grid stabilization.
5. **Gravity-Based Storage:** Lifts heavy masses to store energy and lowers them to generate electricity. Offers long lifespan and low environmental impact but requires large infrastructure. Used for grid-scale storage.
6. **Thermal Energy Storage:** Uses advanced materials to store heat energy, such as molten salts or phase change materials. Provides high energy density but faces stability and complexity issues. Used in solar plants and industrial heating.
7. **Metal-Air Batteries:** Utilize metals and oxygen for high energy density and low-cost storage. However, they have limited rechargeability and efficiency challenges. Used in EVs, grid storage, and electronics.

8. **Liquid Air Energy Storage (LAES):** Stores energy by liquefying air and expanding it to generate electricity. Offers long-duration storage but has low efficiency and high costs. Used for grid and industrial energy management.
9. **Bio-Based Storage:** Uses biological processes (example: microbial fuel cells) for sustainable energy storage. Environmentally friendly but has low efficiency and scalability issues. Suitable for small-scale and waste-to-energy applications.
10. **Quantum Batteries:** Use quantum mechanics for ultra-fast charging and high energy density. Still in theoretical research stages with major technical challenges. Potential future applications include quantum computing and electronics.

IV. Cost of energy storage

the cost of energy storage (Table 2) varies depending on the technology, scale, and application. It is typically measured in \$/kWh (cost per kilowatt-hour of storage capacity) and \$/kW (cost per power output capacity).

Cost Factors

1. **Capital Costs:** Upfront cost of equipment, installation, and infrastructure.
2. **Operational and Maintenance Costs:** Includes repairs, replacements, and efficiency losses.
3. **Cycle Life and Efficiency:** More efficient, long-lasting systems have lower lifetime costs.
4. **Application-Specific Costs:** Grid-scale vs. residential vs. industrial applications.

Table 2. Cost of Different Energy Storage Technologies

Storage Technology	Capital Cost (\$/kWh)	Lifetime Cost (\$/kWh-cycle)	Cycle Life	Efficiency
Lithium-Ion Batteries	\$100 - \$250	\$0.05 - \$0.15	5,000 - 10,000 cycles	85-95%
Lead-Acid Batteries	\$50 - \$150	\$0.10 - \$0.30	500 - 2,000 cycles	70-85%
Sodium-Ion Batteries	\$80 - \$200	\$0.08 - \$0.20	3,000 - 7,000 cycles	85-90%
Flow Batteries	\$150 - \$400	\$0.05 - \$0.12	10,000+ cycles	60-85%
Pumped Hydro Storage	\$200 - \$3000	\$0.02 - \$0.10	40+ years	70-85%
Compressed Air (CAES)	\$50 - \$150	\$0.02 - \$0.08	25+ years	40-70%
Flywheel Storage	\$200 - \$500	\$0.01 - \$0.10	1,000,000+ cycles	85-95%
Supercapacitors	\$300 - \$2000	\$0.01 - \$0.05	1,000,000+ cycles	85-98%

References

1. J.L. LILIEN, Transport et Distribution de l'Energie Electrique, Cours donné à l'Institut d'Electricité Montefiore Université de Liège 2010
2. LAGHZAOU (Amine) Peerhossaini (Donia), stockage de chaleur : energie solaire et autres applications (heat storage: solar energy and other applications, ecole des mines de douai, Promotion 2013 Année Scolaire 2009 -2010
3. ECONB- B, transport des combustibles fossiles au Québec, mars 2016
4. Jairo ESTACIO, Risques technologiques liés au stockage et au transport de combustibles dans le District Métropolitain de Quito, université chambry Annecy, juin 2004
5. Matthieu Mairesse et Jean-Michel Petit, Gaz et liquides combustibles ,Réglementation pour le stockage et l'utilisation, Cahiers de notes documentaires - Hygiène et sécurité du travail - N° 172, 3e trimestre 1998
6. International Energy Agency (IEA): "World Energy Outlook," "Energy Technology Perspectives," and "Global Energy Review." Website: www.iea.org
7. International Maritime Organization (IMO): "IMO Strategy on Reduction of GHG Emissions from Ships" and "MARPOL Convention." Website: www.imo.org
8. U.S. Energy Information Administration (EIA): Reports: "Annual Energy Outlook," "International Energy Statistics," and "Today in Energy." Website: www.eia.gov
9. International Renewable Energy Agency (IRENA): Reports: "Renewable Energy and Electricity Storage" and "Innovation Outlook: Renewable Methanol." Website: www.irena.org
10. World Bank: "Global Gas Flaring Reduction Partnership" and "Sustainable Energy for All." Website: www.worldbank.org
11. BP Statistical Review of World Energy: "Statistical Review of World Energy." Website: www.bp.com
12. International Transport Forum (ITF): "Transport Outlook" and "Decarbonising Transport." Website: www.itf-oecd.org
13. United Nations Conference on Trade and Development (UNCTAD): "Review of Maritime Transport." Website: www.unctad.org
14. International Gas Union (IGU): "World LNG Report" and "Global Gas Report." Website: www.igu.org

15. Maritime Transport: "IMO Strategy on Reduction of GHG Emissions from Ships." IMO (2023) ; "Review of Maritime Transport." UNCTAD (2022); "Innovation Outlook: Renewable Methanol." IRENA (2021); "Statistical Review of World Energy." BP (2023):
16. Road Transport: "Global EV Outlook." IEA (2022); "Decarbonising Transport." ITF (2021); "Annual Energy Outlook." EIA (2023)
17. Rail Transport: "The Future of Rail." IEA (2021); "Railway Handbook." World Bank (2020); "U.S. Coal Transportation." EIA (2023);
18. Pipeline Transport: "Natural Gas Information." IEA (2022); "World LNG Report." IGU (2023); "U.S. Pipeline Infrastructure EIA (2023).
19. Industry Reports: McKinsey & Company: Reports on energy transport and logistics; Deloitte: Insights on energy transition and transport.
20. Government Agencies: U.S. Department of Energy (DOE): www.energy.gov; European Commission: Energy and Transport Statistics.
21. News Outlets: Reuters Energy: www.reuters.com/energy; S&P Global Platts: www.spglobal.com/platts
22. yes Energy, What Is Pumped Hydro Storage, and How Does It Work?, 2022-2025
23. OpenPR, Green Hydrogen Energy Storage System Market is Set To Fly High in 3 Years to Come, 6-14-2023 01:13 PM CET | Energy & Environment
24. Elsa Wimmel / arp, Power to gas ,Nathan Witkop, 11/07/2011
25. Benjamin Duraković, Ozge Buyukdagli, Building energy demand management strategies and methods, sciencedirect 2023
26. What is phase change? by Concept Group LLC, November 1, 2021
27. Crini, Grégorio; Badot, Pierre-Marie, eds. (2010). Sorption processes and pollution : conventional and non-conventional sorbents for pollutant removal from wastewaters. Besançon: Presses universitaires de Franche-Comté. p. 43. ISBN 978-2848673042.
28. Flywheel Energy Storage, Copyright © 2024 Yichun Dawnice Manufacture & Trade Co., Ltd
29. Henry lin, pipeline technology , The Editors of Encyclopaedia Britannica Sep 08, 1998
30. Oil tankers robust and purpose built road transport, Copyright 2025 Terberg Environmental Holding BV
31. Chris Mele, LNG Rail Tank Cars: The Few and the Unknown ,Delaware Currents, February 12, 2021
32. Zahra Ahmed, 10 Biggest Tanker Ships In the World, Marine World, June 29, 2024

33. Cicilsdaily, basics of electric power transmission, copyright © apeirogon technologies private limited, november 8, 2023
34. Ed Maurer , Chapter 5 Flow in open channels, Hydraulics and Water Resources, 09-29-2024
35. Della Anggabrata, CIPP Rehabilitation for Pressure Pipelines, Trenchlesspedia, December 30, 2020 | Last updated: July 5, 2023
36. Pumped Hydro Storage – The Ups and Downs of Water, Alternative Energy Tutorials
37. KTA Staff Large-Diameter Cooling Water Pipe and Penstocks: Selecting and Applying Linings, PCL Magazine, August 2019
38. Andrew Forgrave, Inside the creepy North Wales tunnel that some people and dogs are too scared to enter, By ountryside and tourism editor 12 FEB 2022
39. What is a Hydraulic Accumulator and How Do They Work? BSP hhydraulic Ltd
40. Gravity-flow water systems, Technology brief,
41. What is Wave and Tidal Energy?, Wave and Tidal Energy
42. Apprends les différentes manières dont la chaleur peut se transférer, Parlons sciences, 21 janvier 2021
43. Heat Pipes, Serck, Unipart Group 2025
44. Tingjun Wu and al., Comprehensive Review on Thermoelectric Electrodeposits: Enhancing Thermoelectric Performance Through Nanoengineering , Front. Chem. , 21 December 2021 , Volume 9 - 2021
45. Jintao Huang and al., Advances and Applications of Phase Change Materials (PCMs) and PCMs-based Technologies, ES Materials & Manufacturing, 2021, 13, 23-39

|

Abstract

Energy is a fundamental pillar of economic and industrial development in modern societies. Its production, transport, and storage are major challenges in ensuring a reliable, efficient, and sustainable energy supply. With the continuous growth in global energy demand and the increasing integration of renewable energy sources, energy systems must now address new technical, economic, and environmental constraints. Energy transport and storage play a key role in optimizing energy networks, managing the intermittency of renewable energies, and enhancing energy security. This course aims to introduce the fundamental principles, main technologies, and practical applications of energy transport and storage systems, while considering efficiency, safety, and sustainability aspects.

Key words: Energy transport, Energy storage, Renewable energy, Energy efficiency, Sustainability.

المخلص

تُعدّ الطاقة ركيزة أساسية للتنمية الاقتصادية والصناعية في المجتمعات الحديثة. ويُشكّل إنتاجها ونقلها وتخزينها تحديات كبرى لضمان إمداد طاقي موثوق وفعال ومستدام. ومع النمو المستمر في الطلب العالمي على الطاقة والتزايد المتسارع في إدماج مصادر الطاقة المتجددة، بات لزامًا على أنظمة الطاقة مواجهة قيود تقنية واقتصادية وبيئية جديدة. يلعب نقل الطاقة وتخزينها دورًا محوريًا في تحسين شبكات الطاقة، وإدارة عدم استقرار (تقطّع) الطاقات المتجددة، وتعزيز الأمن الطاقي. ويهدف هذا المقرر إلى تقديم المبادئ الأساسية، والتقنيات الرئيسية، والتطبيقات العملية لأنظمة نقل وتخزين الطاقة، مع مراعاة جوانب الكفاءة والسلامة والاستدامة.

الكلمات المفتاحية:

نقل الطاقة، تخزين الطاقة، الطاقة المتجددة، كفاءة الطاقة، الاستدامة.