

# Comparative Study between FACTS Devices for Power System Transient Stability Improvement with Solar Photovoltaic.

Ikram BOUCETTA\*, Djemai NAIMI\*\*

\* Electric engineering department, LEVRS Laboratory, El-Oued University, Algeria

\*\* Electric engineering department, LGEB Laboratory, Biskra University, Algeria

E-mail : [boucetta-ikram@univ-eloued.dz](mailto:boucetta-ikram@univ-eloued.dz), [d.naimi@univ-biskra.dz](mailto:d.naimi@univ-biskra.dz)

## Abstract

In this paper, a study on the transient stability of power system was performed by using several types of FACTS (Flexible AC Transmission System) such SVC, STATCOM and UPFC, particularly when integrating a significant amount of electrical energy produced by renewable sources, exactly by solar photovoltaic sources. This study is applied on the famous 30 bus IEEE test system, under the Power System Analysis Toolbox (PSAT) simulation software. Based on the critical clearing time (CCT) as a stability index, the simulation results clearly showed the improvement of network stability with superiority in favor of the UPFC over STATCOM and SVC.

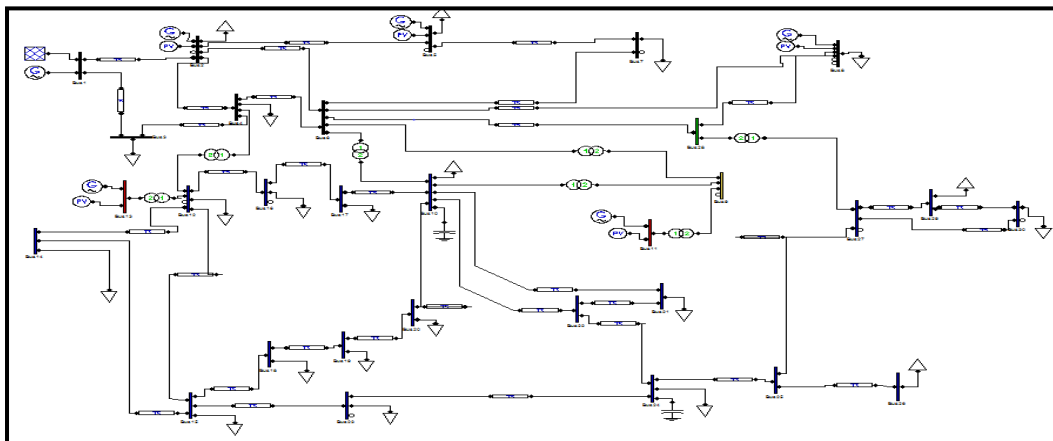
**Keywords:** transient stability, FACTS, solar photovoltaic, PSAT, CCT.

## 1. Introduction

Nowadays, the integration of renewable sources has become unavoidable, this integration may affect the power system stability, the present study concerning the improvement of the integration of a renewable source widely known by the scientific community is photovoltaic solar energy. This paper, focuses on the effect of this integration on the transient stability of the power system [1.2] where the index of this stability is represented by the maximum time during which the grid can withstand the fault without losing its stability this time is known as the critical clearing time (CCT)[3], The use of the FACT system to improve network performance in the presence of this type of renewable source represented by PV source is justified by the opportunity offered by power electronics [4]. A three-phase short circuit is applied to a 30-bus IEEE test system; all simulations are performed under the Power System Analysis Toolbox software (PSAT) [5].

## 2. Test System

The simulation analysis was established on the famous 30 bus IEEE test system by PSAT/ MATLAB, which gives access to an extensive library of grid components.



**Fig.2.** IEEE 30 bus model with PSAT

## 2.1. Characteristics of the Study Model

**Table 1.** Technical data of the study model

Number of Bus	Number of Charges	Number of Generators	Number of Transformers	Number of line of Transmissions
30	21	6	7	33

## 3. Results and Discution

### 3.1. Choice of fault Type

Three-phase short-circuit is chosen as a result of its most dangerous consequences against power system stability.

### 3.2. Analysis Strategy

A comparative study has been carried out with respect to the values of the critical clearing time corresponding to each simulation. This study is divided into three parts :

**Part 1 :** initial state

- Creating a fault at bus “i”, except the reference bus.
- Calculation of critical clearing time with minimum singular value method, in order to identify the most sensitive bus in the presence of the fault.

The same study will be performed for all selected buses.

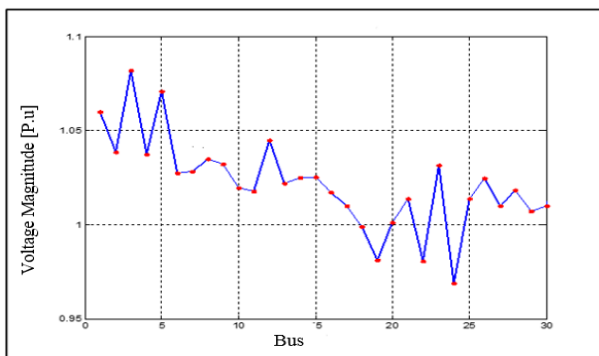
**Part 2:** penetration of the solar photovoltaic (PV).

**Part 3:** improvement of transient stability using an UPFC, the simulation results will be compared with the results of similar and previous research using other types of FACTS such as SVC and STATCOM.[6]

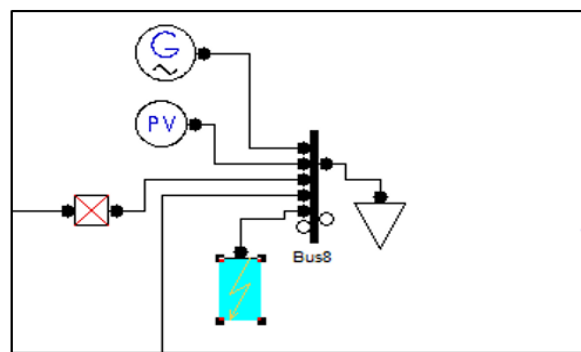
### 3.3. Simulation Results

The performance of the proposed method was tested in the MATLAB/Simulation environment.

*a. Steady State Analysis (Before creating the fault)*      *b. Initial State*

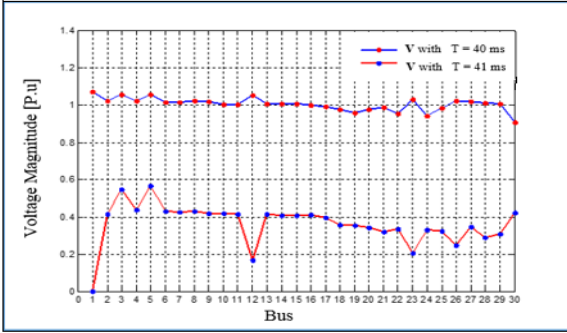


**Fig 5.** Voltage profile



**Fig 6.** Fault location at bus8

**T:** critical clearing time (CCT).

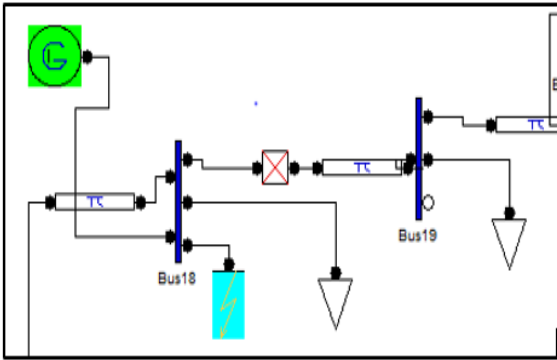


**Fig 6.** Voltage profile at the presence of a fault at bus 8

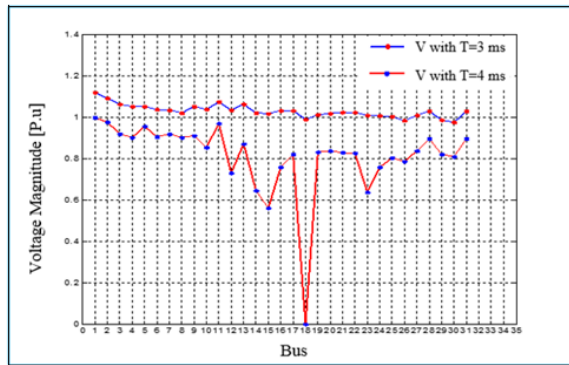
- Steady state analysis of the power grid represents no anomalies were the **Fig 5** shows that the voltage values at all buses are within their acceptable limits (0.90 p.u to 1.1 p.u).
- According to **Fig 6**, we can see that the challenge of just 1(ms) further of the critical clearing time that can cause the instability of the system.

The study performed at bus 8 will be done in the same way for all selected buses.

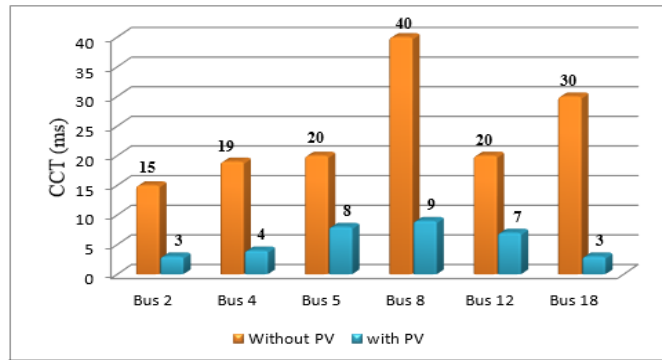
*c. Penetration of the Solar Photovoltaic (PV)*



**Fig 7.** Penetration of a solar PV at bus 18



**Fig 8.** Voltage profile at bus 18



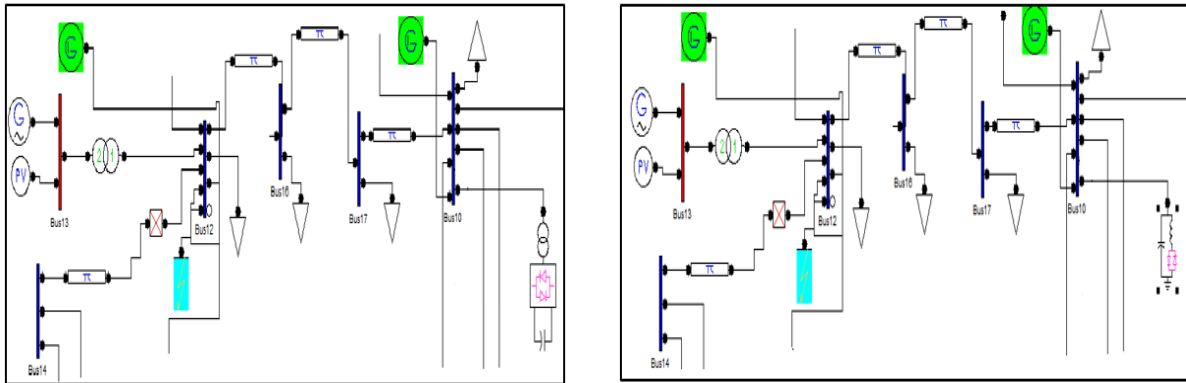
**Fig 9.** CCT comparison histogram with and without PV integration

According to **Fig 8** and **Fig 9**, it is clear that the penetration of solar PV has enormously reduced the CCT and consequently the ability of the electrical network to maintain its stability during the fault in all the cases studied. This is due to the inability of the PV to participate in the setting of the voltage plan in the absence of reactive energy in such sources.

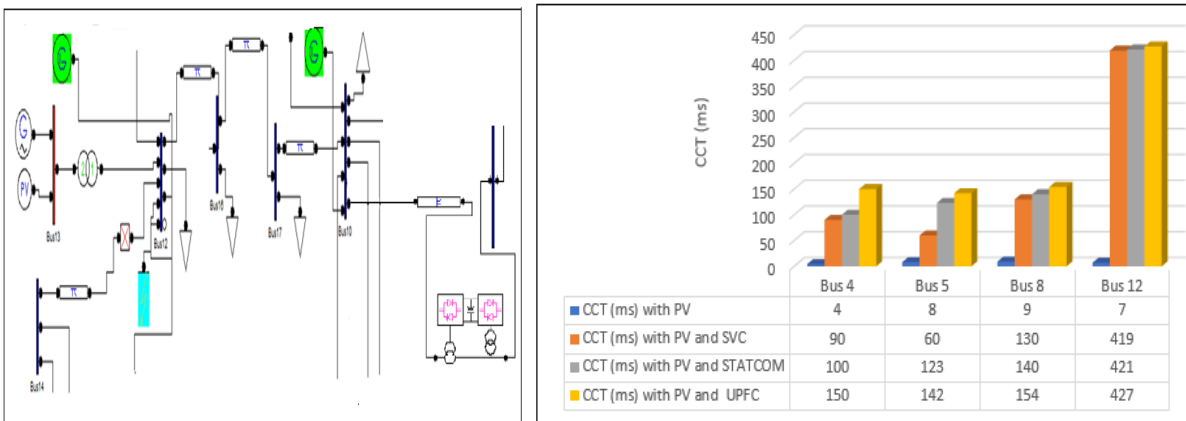
*d. Improvement of transient stability using FACTS devices*

The use of the FACTS system is justified to improve the network's ability to withstand faults for longer periods of time. The integration of FACTS devices into power systems requires new methods for the study and analysis of power systems.

In this section, an SVC, STATCOM and UPFC has been introduced in order to checking their influence on solar power penetration. After several simulations important results are achieved:



**Fig 10.** localization of SVC and STATCOM respectively



**Fig 10.** localization of UPFC

**Fig. 12.** CCT comparison histogram

After the integration of FACTS (UPFC, SVC and STATCOM) it can be seen that a considerable improvement in the CCT has been noticed, which will provide an opportunity to integrate more energy from PV sources. UPFC as shown in the histogram in **Fig 12** shows a modest superiority over STATCOM and SVC.

#### 4. Conclusion

This paper has mainly focused on the assessment of power system transient stability by determinate a critical clearing time (CCT) for the several cases by observing the behavior simulation of a test system during grid faults using a Power System Analysis Toolbox (PSAT).

According to previously simulations, we find that:

- The penetration of solar PV has reduced the CCT and thus the ability of the electrical network to maintain its stability during the fault in all the cases studied.
- A considerable improvement in the CCT has been noticed after the integration of FACTS (UPFC, SVC, STATCOM).

The use of UPFC has allowed a considerable improvement in the margin of stability.

- The simulation results clearly showed that there is an opportunity to integrate more energy from PV sources into the power grid through FACTS.

## References

1. M. Yagami, S. Ishikawa, Y. Ichinohe, K. Misawa and J.Tamura'' Transient Stability Analysis of Power System with Photovoltaic Systems Installed'' Journal of Energy and Power Engineering 9, October 31, 2015)
2. D. Remon ; A. M. Cantarellas ; J. M.Mauricio ; P. Rodriguez. ''Power system stability analysis under increasing penetration of photovoltaic power plants with synchronous power controllers''. IET Renew. Power Gener. 2017, 11, 733–741.
3. K. G. Damor and D. M. Patel ''Improving Power System Transient Stability by using Facts Devices'' International Journal of Engineering Research &Technology (IJERT) ISSN: 2278-0181, Vol. 3 Issue 7, July – 2014.
4. N. Khan, H. Ahmad and A. Khattak ''Transient Stability Enhancement of Power System Using UPFC'' International Journal of Engineering Works, Kambohwel Publisher Enterprises. ISSN: 2409-2770, Vol. 4, Issue 2, PP. 33-40, February 2017.
5. Federico Milano, Power System Analysis Toolbox Documentation for PSAT version 2.0.0  $\beta$ 1, July 9, 2006.
6. I. Boucetta, D. Naimi, A. Salhi and L. Zellouma '' Enhancement of power system transient stability with a large penetration of solar photovoltaic using facts'' 4th International Conference on Electrical Engineering and Control Applications (ICEECA2019) in Constantine on 17-19 December 2019.